

- CED 500 Non Carbonated     CED 1500 Non Carbonated

CED 1500 Non Carbonated



### Optional Accessories

Lighted Marquee

Leg Kit

Certified by these agencies:



#### CUSTOMER SERVICE

Should you require more information about our products, please do not hesitate to contact our customer service team at [custserv@lancerworldwide.com](mailto:custserv@lancerworldwide.com).

Lancer's **CED Non Carbonated Dispensers** are designed using the highest quality materials and proven technology providing our customers with consistent drink quality.

### Features

- Stainless steel construction exterior and interior
- Available with 4, 5 or 6 post-mix dispensing valves that can be serviced independently
- Insulation is CFC-free, 0 GWP, structural foam
- All installation from front of unit
- CFC-free, R134A refrigerant
- Flex manifold configuration for multiple non-carbonated drinks
- Ambient or chilled syrup lines
- Syrup & water inlets: 3/8" (9.5 mm) male barb
- LEV® valves standard, other valves available upon request
- Key lock switch
- Lancer electronic ice bank control
- 24V secondary transformer



#### WARRANTY

For warranty specifics by product, contact your Lancer Sales Representative. Equipment design and/or specifications are subject to change without notice.

For more information visit [lancerworldwide.com](http://lancerworldwide.com) or call 1-888-846-6729

CED 500 Non Carbonated     CED 1500 Non Carbonated

Counter Electric Non Carbonated Dispensers

#### CED 1500 Non Carbonated

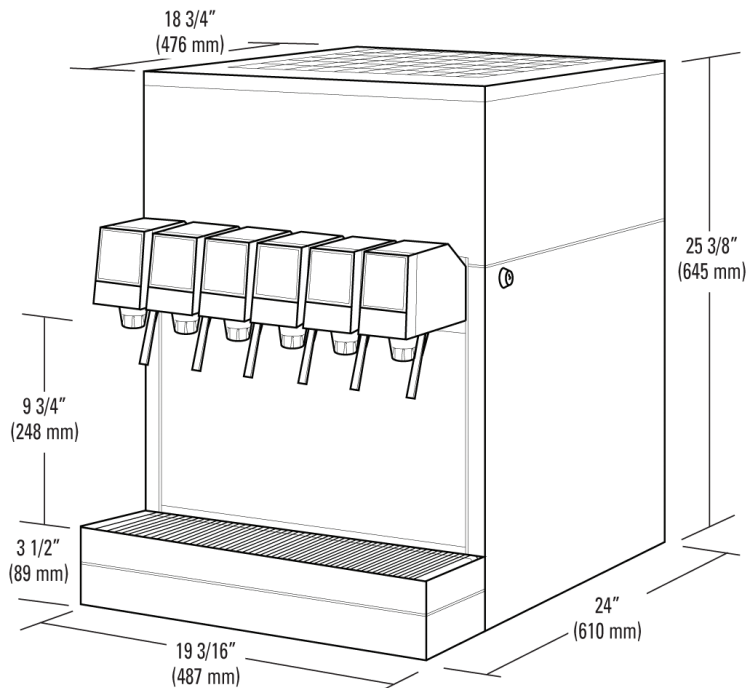

### Distinctive Design

Valves are post-mix dispensing and can be serviced independently

- 4 valves (2-2)
- 5 valves (2-2-1)
- 6 valves (3-2-1)

#### Dimensions

CED 500 - 27.5" H x 10.375" W x 25.25" D  
(699 mm H x 264 mm W x 641 mm D)

CED 1500 - 25.375" H x 19.187" W x 24" D  
(645 mm H x 487 mm W x 610 mm D)

#### Weight

CED 500 - Empty: 89 lbs (40kg) - Operating: 131 lbs (59 kg)  
Shipping: 108 lbs (49 kg)

CED 1500 - Empty: 130 lbs (59 kg) - Operating: 230 lbs (104 kg)  
Shipping: 170 lbs (77 kg)

#### Ice

CED 500 - Bank Weight: 17 lbs (7.7 kg)

CED 1500 - Bank Weight: 30 lbs (13.6 kg)

#### Electrical

CED 500 - 115V/60Hz, 7 Amps - 230V/50Hz, 3.3 Amps

CED 1500 - 115V/60Hz, 7.8 Amps - 230V/50Hz, 4.5 Amps

#### Water Bath

CED 500 - Capacity: 5 gal (19L)

CED 1500 - Capacity: 12 gal (45L)

#### Compressor

CED 500 - 1/4 hp

CED 1500 - 1/3 hp

#### Motors

CED 500 - Agitator: 15 w - Condenser fan: 9 w

CED 1500 - Agitator: 25 w - Condenser fan: 9 w

For more information visit [lancerworldwide.com](http://lancerworldwide.com) or call 1-888-846-6729