



Ice Dispenser 22" - Model 4400

LANCER INSTALLATION GUIDE



FOR QUALIFIED INSTALLER ONLY. This basic Installation Sheet is an initial release. If a complete Operations Manual (for the unit being installed) is required or needed, please refer to the Lancer web site (lancercorp.com) for immediate access, or for your convenience, scan this QR code with a mobile device (app required) for immediate access to other Technical Documents and alternative translations (if available) pertaining to this unit. Contact Lancer Customer Service for assistance as required.

ABOUT THIS MANUAL

This booklet is an integral and essential part of the product and should be handed over to the operator after the installation and preserved for any further consultation that may be necessary. Please read carefully the guidelines and warnings contained herein as they are intended to provide the user with essential information for the continued safe use and maintenance of the product. In addition, it provides **GUIDANCE ONLY** to the user on the correct services and site location of the unit.

BEFORE GETTING STARTED

Each unit is tested under operating conditions and is thoroughly inspected before shipment. At the time of shipment, the carrier accepts responsibility for the unit. Upon receiving the unit, carefully inspect the carton for visible damage. If damage exists, have the carrier note the damage on the freight bill and file a claim with carrier. Responsibility for damage to the dispenser lies with the carrier.

The installation and relocation, if necessary, of this product must be carried out by qualified personnel with up-to-date safety and hygiene knowledge and practical experience, in accordance with current regulations.

IMPORTANT SAFETY INSTRUCTIONS

⚠ Intended Use

The dispenser is for indoor use only. This unit is not a toy. Children should not be supervised not to play with appliance. It should not be used by children or infirm persons without supervision. This appliance is not intended for use by persons (including children) with reduced physical, sensory or mental capabilities, or lack of experience and knowledge, unless they have been given supervision or instruction concerning use of the appliance by a person responsible for their safety. Cleaning and user maintenance shall not be performed by children without supervision. The min/max ambient operating temperature for the dispenser is 40°F to 105°F (4°C to 41°C). Do not operate unit below minimum ambient operation conditions. Should freezing occur, cease operation of the unit and contact authorized service technician. Service, cleaning and sanitizing should be accomplished only by trained personnel. Applicable safety precautions must be observed. Instruction warnings on the product being used must be followed.



4500

Revision: September 2018

Lancer PN: 28-3008

⚠ Electrical Warning

Check the dispenser name plate label, located behind the splash plate, for the correct electrical requirements of unit. Do not plug into a wall electrical outlet unless the current shown on the serial number plate agrees with local current available. Follow all local electrical codes when making connections. Each dispenser must have a separate electrical circuit. Do not use extension cords with this unit. Do not 'gang' together with other electrical devices on the same outlet. The keyswitch does not disable the line voltage to the transformer primary. Always disconnect electrical power to the unit to prevent personal injury before attempting any internal maintenance. The resettable breaker switch should not be used as a substitute for unplugging the dispenser from the power source to service the unit. Only qualified personnel should service internal components of electrical control housing. Make sure that all water lines are tight and units are dry before making any electrical connections!

⚠ Water Notice

Provide an adequate potable water supply. Water pipe connections and fixtures directly connected to a potable water supply must be sized, installed, and maintained according to federal, state, and local laws. The water supply line must be at least a 3/8 inches (9.525 mm) pipe with a minimum of 25 PSI (0.172 MPA) line pressure, but not exceeding a maximum of 50 PSI (0.345 MPA). Water pressure exceeding 50 PSI (0.345 MPA) must be reduced to 50 PSI (0.345 MPA) with the provided pressure regulator. Use a filter in the water line to avoid equipment damage and beverage off-taste. Check the water filter periodically, as required by local conditions. The water supply must be protected by means of an air gap, a backflow prevention device or another approved method to comply with NSF standards. A leaking inlet water check valve will allow carbonated water to flow back through the pump when it is shut off and contaminate the water supply. Ensure the backflow prevention device complies with ASSE and local standards. It is the responsibility of the installer to ensure compliance.

⚠ Automatic Agitation

Units are equipped with an automatic agitation system and will activate unexpectedly. Do not place hands or foreign objects in the ice bin. Unplug the dispenser during servicing, cleaning, and sanitizing. To avoid personal injury, do not attempt to lift the dispenser without assistance. For heavier dispensers, use a mechanical lift.

SPECIFICATIONS

ID 4400 - 22" Cubed Ice

DIMENSIONS

Width: 22.0 inches (559 mm)
Depth: 30.5 inches (775 mm)
Height: 35.375 inches (899 mm)

ELECTRICAL

115 VAC / 60 Hz / 3.0 Amps
230 VAC / 50 Hz / 1.5 Amps

WEIGHT

Shipping: 170 lbs (77 kg)
With Ice: 320 lbs (145 kg)
Ice Capacity: 180 lbs (82 kg)
Ice Dispensable: 150 lbs (68 kg)

FITTINGS

Plain/Carb Water Inlet: 3/8 inch barb

PLAIN WATER SUPPLY

Min Flowing Pressure: 25 PSI (0.172 MPA)
Max Flowing Pressure: 65 PSI (0.448 MPA)

This unit emits a sound pressure level below 70 dB

ID 4400N - 22" Nugget Ice

DIMENSIONS

Width: 22.0 inches (559 mm)
Depth: 30.5 inches (775 mm)
Height: 39.948 inches (1014.67 mm)

ELECTRICAL

115 VAC / 60 Hz / 3.0 Amps
230 VAC / 50 Hz / 1.5 Amps

WEIGHT

Shipping: 185 lbs (84 kg)
With Ice: 340 lbs (154.2 kg)
Ice Capacity: 200 lbs (90.7 kg)
Ice Dispensable: 170 lbs (77.1 kg)

FITTINGS

Plain/Carb Water Inlet: 3/8 inch barb

PLAIN WATER SUPPLY

Min Flowing Pressure: 25 PSI (0.172 MPA)
Max Flowing Pressure: 65 PSI (0.448 MPA)

This unit emits a sound pressure level below 70 dB

INSTALLATION

READ THIS MANUAL

This manual was developed by the Lancer Corporation as a reference for the owner/operator and installer of this dispenser. Please read this guide before installation and operation of this dispenser. If service is required please call your Lancer Service Agent or Lancer Customer Service. Always have your model and serial number available when you call.

Your Service Agent: _____

Service Agent Telephone Number: _____

Serial Number: _____

Model Number: _____

Unpack the Dispenser

1. Set shipping carton upright on the floor then cut package banding straps and remove.
2. Open top of carton and remove interior packaging.
3. Lift carton up and off of the unit.
4. Remove plywood shipping base from unit by moving unit so that one side is off the counter top or table allowing access to screws on the bottom of the plywood shipping base.

NOTE

If unit is to be transported, it is advisable to leave the unit secured to the plywood shipping base.

5. Remove accessory kit and loose parts from ice compartment.

NOTE

Inspect unit for concealed damage. If evident, notify delivering carrier and file a claim against the same.

6. If leg kit has been provided, assemble legs by tilting unit.

Selecting/Preparing Counter Location

NOTE

The dispenser should only be installed in a location where it can be overseen by trained personnel

1. Select a level, well ventilated location that is in close proximity to a properly grounded electrical outlet, within five (5) feet (1.5 m) of a drain, a water supply that meets the requirements shown in the Specifications section found on page 2, and away from direct sunlight or overhead lighting.
2. Sufficient clearance must be provided, if an ice maker is not installed, to allow filling ice compartment from a five gallon bucket (a minimum of 16 inches is recommended).
3. The selected location should be able to support the weight of the dispenser, ice and possibly an icemaker being installed after counter cut out is made. Total weight (with icemaker) for this unit could exceed 800 pounds (363.6kg).

4. Unit may be installed directly on countertop or on legs. If installed directly on the counter, unit must be sealed to the countertop with an FDA approved sealant. If an icemaker is to be mounted on top of dispenser, do not install dispenser on legs.

NOTE

NSF listed units must be sealed to the counter or have four (4) inch legs installed.

NOTE

Lancer does *NOT* recommend the use of shaved or flake ice in the dispenser.

5. In order to facilitate proper dispenser drainage, ensure that the dispenser is level, front to back and side to side. Place a level on the top of the rear edge of the dispenser. The bubble must settle between the level lines. Repeat this procedure for the remaining three sides. Level unit if necessary. For optimum performance place the unit at a 0° tilt. The maximum tilt is 5°.

Installing an Icemaker (if necessary)

⚠ ATTENTION

When installing an icemaker on the dispenser, use a bin thermostat to control the ice level (see below). This will prevent damage to the dispensing mechanism. The bracket for mounting a thermostat is located in the ice bin. During the automatic agitation cycle and while dispensing ice, ensure there is adequate space between the top of the ice level and the bottom of the icemaker so the ice can move without obstruction. Contact your icemaker manufacturer for information on a suitable bin thermostat.

1. Install the icemaker per manufacturer specifications. Points of consideration include drainage, ventilation, and drop zones.
2. An adapter plate is required when installing an icemaker. Contact your Sales Representative or Lancer Customer Service for more information.

- A bin thermostat is required in order to control the level of ice in the dispenser (Refer to ATTENTION to the left). Contact your icemaker manufacturer to obtain the correct bin thermostat.
- Bin thermostat should be a minimum of 2" below the top edge of the dispenser. The preferred location of the bin thermostat is on the left side wall.

Attach Bin Stat Bracket As Shown Recommended Bin Stat Attachment

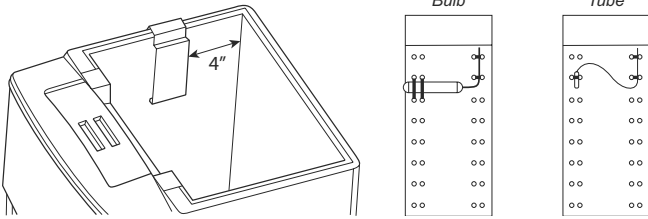

ATTENTION

Failure to use an ice bin thermostat will not only void your IBD's warranty but will result in the inability to control the level of ice in the ice bin which can cause damage to your dispenser.

- Ensure the icemaker is installed properly to allow for removal of the Merchandiser.
- Ensure manual fill is accessible.
- Clean and maintain icemaker per manufacturer's instructions.

Dispenser Installation

NOTE

The installation, and relocation if necessary, must be carried out by qualified personnel with up-to-date knowledge and practical experience, in accordance with current regulations.

- Route appropriate tubing from the water source to the plain water inlet at the front of the unit and connect tubing to inlet using the oetiker pliers and fittings.
- Connect tubing to water source then flush water lines to check for leaks.
- Route drain hose from designated open type drain to fitting on Drip Tray and connect hose to fitting.

CAUTION

Drain line must be insulated with a closed cell insulation. Insulation must cover the entire length of the drain hose, including fittings. The drain should be installed in such a manner that water does not collect in sags or other low points, as condensation will form.

ATTENTION

Pouring hot water down the drain may cause the Drain Tube to collapse. Allow only luke warm or cold water to enter the Drain Tube. Pouring coffee, tea, or other similar substances down the drain may cause the Drain Tube to become clogged.

- Reattach Drip Tray/Cup Rest to unit.
- Route the power supply cord to a grounded electrical outlet of the proper voltage and connect to outlet.

WARNING

The dispenser must be properly electrically grounded to avoid serious injury or fatal electrical shock. The power cord has a three-prong grounded plug. If a three-hole grounded electrical outlet is not available, use an approved method to ground the unit. Follow all local electrical codes when making connections. Each dispenser must have a separate electrical circuit. Do not use extension cords. Do not connect multiple electrical devices on the same outlet.

- Test the motor operation by pushing the ice chute lever until agitator motor begins to turn.
- Activate each valve to ensure a good flow of water is achieved.

Adjusting The Ice Flow Regulator (230 V Units Only)

NOTE

The Regulator Door Assembly (PN 82-2904) can regulate the dispensed ice flow. Installation of an Ice Flow Regulator is NOT necessary for the dispensing of ice. This IBD unit will dispense ice unrestricted.

- Remove Bin Lids.
- Adjust Ice Regulator to desired position by turning the nut screw clockwise to close, or counter clockwise to open, with the use of a nut driver or a socket wrench.

NOTE

The total adjustment is 1/2 inch.

- Reinstall bin lids.

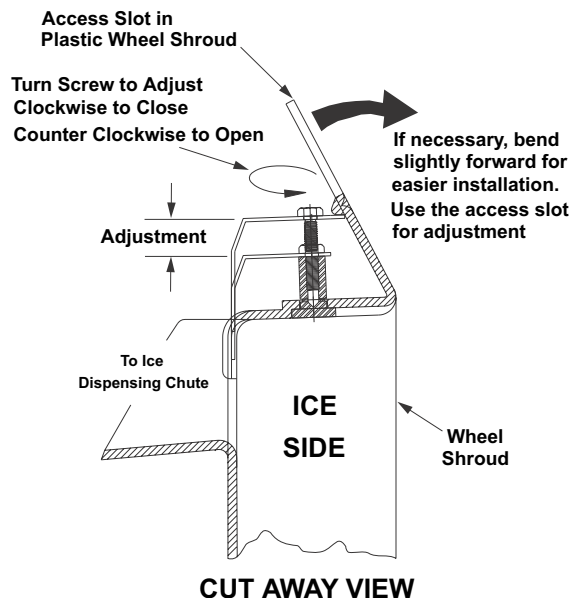

CUT AWAY VIEW

CLEANING AND SANITIZING

GENERAL INFORMATION

Lancer equipment (new or reconditioned) is shipped from the factory cleaned and sanitized in accordance with NSF guidelines. The operator of the equipment must provide continuous maintenance as required by this manual and/or state and local health department guidelines to ensure proper operation and sanitation requirements are maintained.

The cleaning procedures provided herein pertain to the Lancer equipment identified by this manual. If other equipment is being cleaned, follow the guidelines established by the manufacturer for that equipment.

Cleaning should be accomplished only by trained personnel. Sanitary gloves are to be used during cleaning operations. Applicable safety precautions must be observed. Instruction warnings on the product being used must be followed.

⚠ ATTENTION

- Use sanitary gloves when cleaning the unit and observe all applicable safety precautions.
- **DO NOT** use a water jet to clean or sanitize the unit.
- **DO NOT** disconnect water lines when cleaning and sanitizing syrup lines, to avoid contamination.
- **DO NOT** use strong bleaches or detergents; These can discolor and corrode various materials.
- **DO NOT** use metal scrapers, sharp objects, steel wool, scouring pads, abrasives, or solvents on the dispenser.
- **DO NOT** use hot water above 140° F (60° C). This can damage the dispenser.
- **DO NOT** spill sanitizing solution on any circuit boards. Insure all sanitizing solution is removed from the system.

Cleaning Solution

Mix a mild, non-abrasive detergent (e.g. Sodium Laureth Sulfate, dish soap) with clean, potable water at a temperature of 90°F to 110°F (32°C to 43°C). The mixture ratio is one ounce of cleaner to two gallons of water. Prepare a minimum of five gallons of cleaning solution. Do not use abrasive cleaners or solvents because they can cause permanent damage to the unit. Ensure rinsing is thorough, using clean, potable water at a temperature of 90°F to 110°F. Extended lengths of product lines may require additional cleaning solution.

Sanitizing Solution

Prepare the sanitizing solution in accordance with the manufacturer's written recommendations and safety guidelines. The type and concentration of sanitizing agent recommended in the instructions by the manufacturer shall comply with 40 CFR §180.940. The solution must provide 200 parts per million (PPM) chlorine (e.g. Sodium Hypochlorite or bleach) and a minimum of five gallons of sanitizing solution should be prepared.

Daily Cleaning

1. Using the cleaning solution, clean top cover and all exterior stainless steel surfaces.
2. Clean exterior of dispensing valves and ice chute.
3. Remove cup rest then clean the drip tray and cup rest. Replace cup rest and drip tray when finished.
4. Wipe clean all splash areas using a damp cloth soaked in cleaning solution.

Ice Bin Cleaning - Start-Up and Monthly

NOTE

Refer to the Automatic Agitation Warning on page 2.

1. Disconnect power to the dispenser
2. Remove Top Cover.
3. Melt out any remaining ice from the bin.
4. Remove Agitator Pin from Agitator Shaft. Slide Agitator Shaft rearward out Hub and pull out of rear Bearing to remove.
5. Remove Ice Shroud by lifting and rotating out from beneath the auger.
6. Use the Cleaning Solution, and a clean cloth or soft brush, to clean all removable parts, sides of the Ice Bin, Auger, and surface of the aluminum casting.
7. Using the Cleaning Solution and the sponge brush provided, clean all interior surfaces of the ice chute and the ice chute feed through.
8. Repeat Step 6 for all exterior surfaces of the dispenser.
9. Using hot water, thoroughly rinse away the cleaning solution.
10. Wearing sanitary gloves, soak and clean cloth towel in Sanitizing Solution and wash all surfaces of removable parts, sides of the Ice Bin, Auger, and surface of the aluminum casting.
11. Using the Sanitizing Solution and the sponge brush provided, clean all interior surfaces of the ice chute and the ice chute feed through.
12. Repeat Step 10 for all exterior surfaces of the dispenser.
13. Wearing sanitary gloves, reassemble all removable parts. Ensure agitator clip is locked.
14. Fill Unit with ice and replace Top Cover.
15. Reconnect Dispenser to power source.

Ice Chute Cleaning - Monthly

NOTE

It is recommended to perform this procedure monthly, or more often if desired. Use the cleaning solution described above. An alternate solution of one part water to one part vinegar may be used to remove water spots and calcium deposits.

1. Turn off power to the dispenser.
2. Remove Merchandiser.
3. Remove Ice Chute Lever, then remove Splash Plate Assembly by lifting it up and out from the dispenser face.

NOTE

Always remove the ice chute lever before removing the splash plate.

4. Remove the Ice Chute Assembly base by removing the four (4) screws that attach it to the unit.
5. Prepare the Cleaning Solution.
6. Soak the Ice Chute Assembly in the solution.
7. Rinse and dry the Ice Chute Assembly thoroughly.
8. Reinstall the Ice Chute Assembly.
9. Reinstall Merchandiser and Splash Plate.
10. Reconnect power to the dispenser.

TROUBLESHOOTING

Dispenser Troubleshooting

TROUBLE	CAUSE	REMEDY
Push chute; no response.	<ol style="list-style-type: none"> 1. Dispenser not connected to power source. 2. Wiring harness not plugged in. 3. PC board defective. 4. Malfunctioning power supply. 	<ol style="list-style-type: none"> 1. Connect dispenser to power source. 2. Plug in wiring harness. 3. Replace PC board. 4. Check voltage to power supply. Check fuses.
Push chute, ice door opens but motor does not run.	<ol style="list-style-type: none"> 1. Wiring harness not plugged in. 2. PC board defective. 3. Motor defective. 	<ol style="list-style-type: none"> 1. Plug in wiring harness. 2. Replace PC board. 3. Replace motor.
Push chute, motor runs but ice door does not open.	<ol style="list-style-type: none"> 1. Solenoid not connected to PC board. 2. Solenoid defective. 3. PC board defective. 	<ol style="list-style-type: none"> 1. Connect solenoid to PC board. 2. Replace solenoid. 3. Replace PC board.
Push chute, ice door opens, motor runs, but ice does not dispense, or ice is of poor quality.	<ol style="list-style-type: none"> 1. Dispenser is out of ice. 2. Agitator pin is missing or damaged. 3. Poor ice quality. 4. Key not installed on agitation shaft. 	<ol style="list-style-type: none"> 1. Fill dispenser with ice. 2. Replace agitator pin. 3. Service ice machine. 4. Install key on agitation shaft.
Water in ice bin.	<ol style="list-style-type: none"> 1. Coldplate drain is obstructed. 	<ol style="list-style-type: none"> 1. Remove splash plate and drip tray to obtain access to drain tubes and clear accordingly.
Water leakage around water spigot.	<ol style="list-style-type: none"> 1. Damaged or improperly installed o-rings. 	<ol style="list-style-type: none"> 1. If damaged, replace. If improperly installed, adjust.
Miscellaneous leakage.	<ol style="list-style-type: none"> 1. Gap between parts. 2. Damaged or improperly installed o-rings. 	<ol style="list-style-type: none"> 1. Tighten appropriate retaining screws. 2. Replace or adjust appropriate o-rings.

Automatic Agitation and Low Ice Alarm Control

NOTE

Each Series 4500 ice beverage dispenser is equipped with automatic agitation for the ice bin. The unit is shipped with timing set at two (2) seconds ON every 60 minutes. Referring to the tables on the wiring diagram (located on next page and affixed to the electrical box cover), the automatic agitation timing can be changed as follows. A set of DIP switches is provided to control the timing and low ice control. Dispensers using pellet ice must have the automatic agitation settings adjusted to four (4) seconds ON every 150 minutes. Refer to Automatic Agitation Warning on page 3.

DIP#	DESCRIPTION
DIP#1	This switch controls the low ice indicator light. With the switch in the ON position, the light operates when a low ice condition exists. In the OFF position, the light is turned off. The unit is shipped with the light switch in the ON position.
DIP#2	This switch controls the low ice audible alarm. With the switch in the ON position, the alarm operates when a low ice condition exists. In the OFF position, the alarm is turned off. The unit is shipped with the alarm switch in the OFF position.
DIP#3 and DIP#4	These switches control the ON time for automatic agitation. By referring to the table and setting the switches as shown, ON times from one (1) second to four (4) seconds [in one (1) second increments] can be obtained. EXAMPLE: For three (3) seconds ON time, switch 3 should be in the ON position, and switch 4 should be in the OFF position. The unit is shipped with two (2) seconds ON time.
DIP#5 - #8	<ol style="list-style-type: none"> These switches control the OFF time for automatic agitation. By referring to the table and setting the switches as shown, OFF times from 10 minutes to 150 minutes (in 10 minute increments) can be obtained. EXAMPLE: For 40 minute OFF time, switch 5 should be in the OFF position, switch 6 should be in the ON position, switch 7 should be in the OFF position, and switch 8 should be in the OFF position. The unit is shipped with 60 minute OFF time. To turn the agitation completely off, set switches 5 through 8 all OFF.

Switch Number				Agitation Off Time
5	6	7	8	
O	O	O	O	No Agitation
O	O	O	X	10 Minutes
O	O	X	O	20 Minutes
O	O	X	X	30 Minutes
O	X	O	O	40 Minutes
O	X	O	X	50 Minutes
O	X	X	O	60 Minutes
O	X	X	X	70 Minutes
X	O	O	O	80 Minutes
X	O	O	X	90 Minutes
X	O	X	O	100 Minutes
X	O	X	X	110 Minutes
X	X	O	O	120 Minutes
X	X	O	X	130 Minutes
X	X	X	O	140 Minutes
X	X	X	X	150 Minutes

Switch #		Agitation On Time
3	4	
O	O	1 Second
O	X	2 Seconds
X	O	3 Seconds
X	X	4 Seconds

Key
X = On
O = Off

Switch 1: "Low Ice" LED Indicator

Switch 2: "Low Ice" Alarm

Switch 3-4: Agitation On Time

Switch 5-8: Agitation Off Time

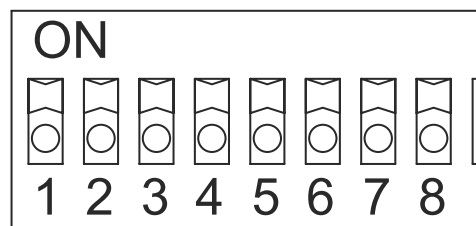

Up = On
Down = Off

Cube Ice Setting:

Agitation On Time: 2 Seconds

Agitation Off Time: 60 Minutes

Pellet Ice Setting:

Agitation On Time: 4 Seconds

Agitation Off Time: 150 Minutes

ILLUSTRATIONS & PART LISTINGS

Final Assembly - ID 4400 Cubed Ice

NOTE:
TO ADJUST ICE FLOW
REGULATOR, SEE PAGE 4
(230 VOLT ONLY)

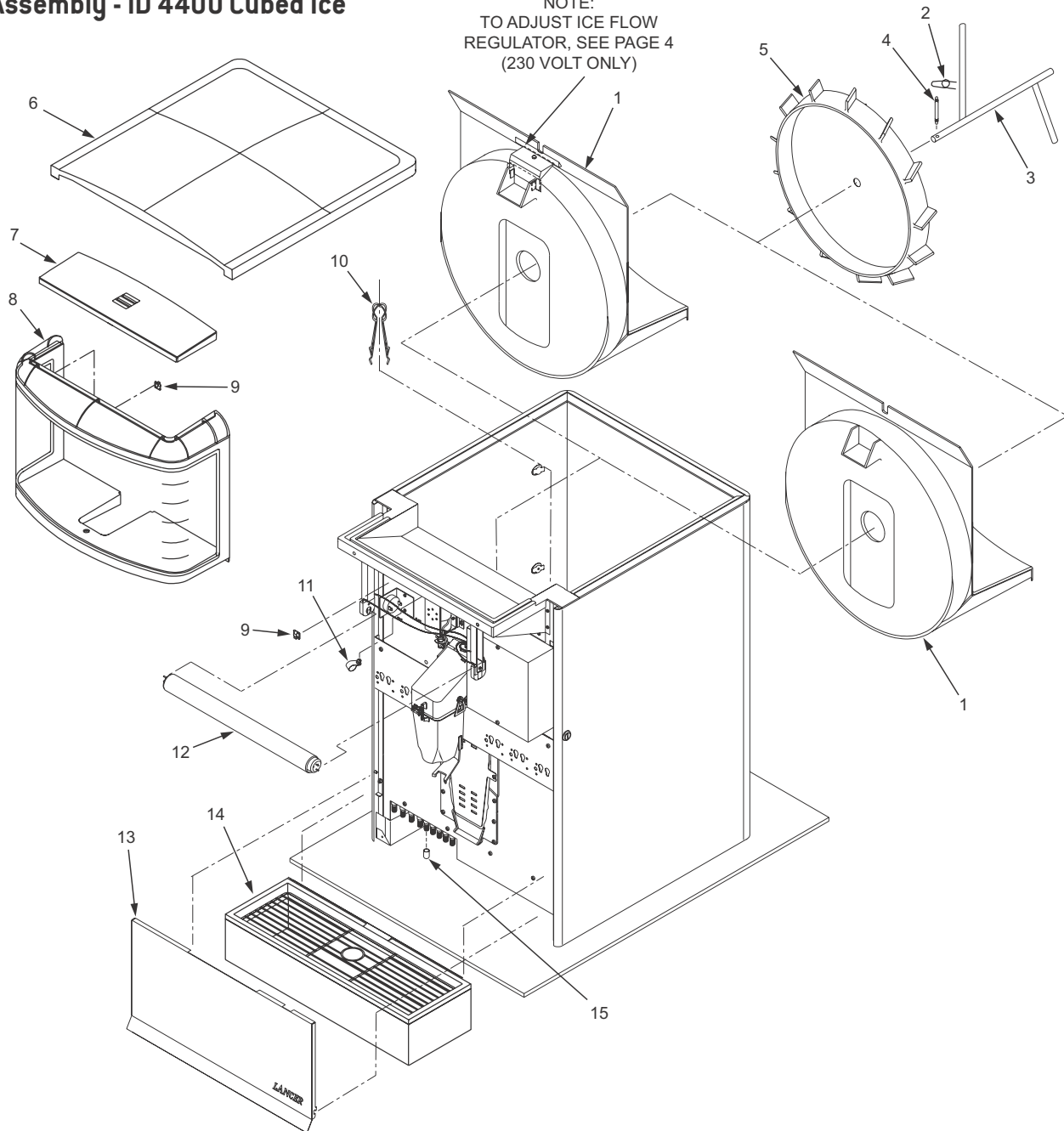

<u>Item</u>	<u>Part No.</u>	<u>Description</u>
1	05-1309/02	Wheel Shroud, IBD22
-	82-1892/01	Wheel Shroud Assy, IBD22, Mod (230V ONLY)
2	03-0368	Retainer, RUE-14-S
3	23-1373	Agitator Assy, HEX, IBD (115V)
-	23-1355	Agitator Assy, IBD (230V Only)
4	10-0762	Pin, Agitator, IBD, Single Retainer
5	82-3556	Dispensing Wheel Assy, HEX, IBD (115V)
-	82-3413	Dispensing Wheel Assy, IBD (230V Only)
6	05-1467	Lid, Back, IBD22, Round
7	05-1476	Lid, Front, IBD, Round
8	82-2630	Merchandiser Assy, IBD, 22 Inch, Rd
9	03-0300	Wire Clip, Adhesive
10	23-1038/01	Drain, Spider, IBD
11	03-0049	Clip, Cord
12	12-0146/01	Lamp, 18 Inch, 15W, T8
13	30-8466	Plate, Splash, IBD, 22 Inch Wide
14	82-3175-SP	Drip Tray Assy, IBD, 22 Inch Wide
15	04-0559	Cap, Protective, Vinyl, VC-375-8

Pellet Ice Dispenser Sub-Assembly Conversion Kit, IBD22, PN: 82-3955

ATTENTION

The Pellet Ice Components listed below are to be used *ONLY* in conjunction with Nugget, Cubelet, or Chewblet ice. *LANCER* makes no warranty of any kind with regard to these components being used with any other kind of ice.

Item	Part No.	Description
1	02-0577	Grommet, Rubber, G3002
2	03-0368	Retainer, Pin, Agitator, IBD
3	05-2325/02	Nugget Ice Liner Bin, IBD22
4	23-1401/03	Agitator Assy, Helical, IC, Hex
5	82-3703	Extension Assy, 4 1/2", IBD22
6	42-0111	Foamed Cover, Scots/Hoshi, Pellet Ice
7	30-9446	Adapter, Mech Bin-Stat, Scots
8	82-3651	Dispensing Wheel Assy, Pellet Ice, Hex
9	30-9801/02	Shield, Nugget Ice, IBD22

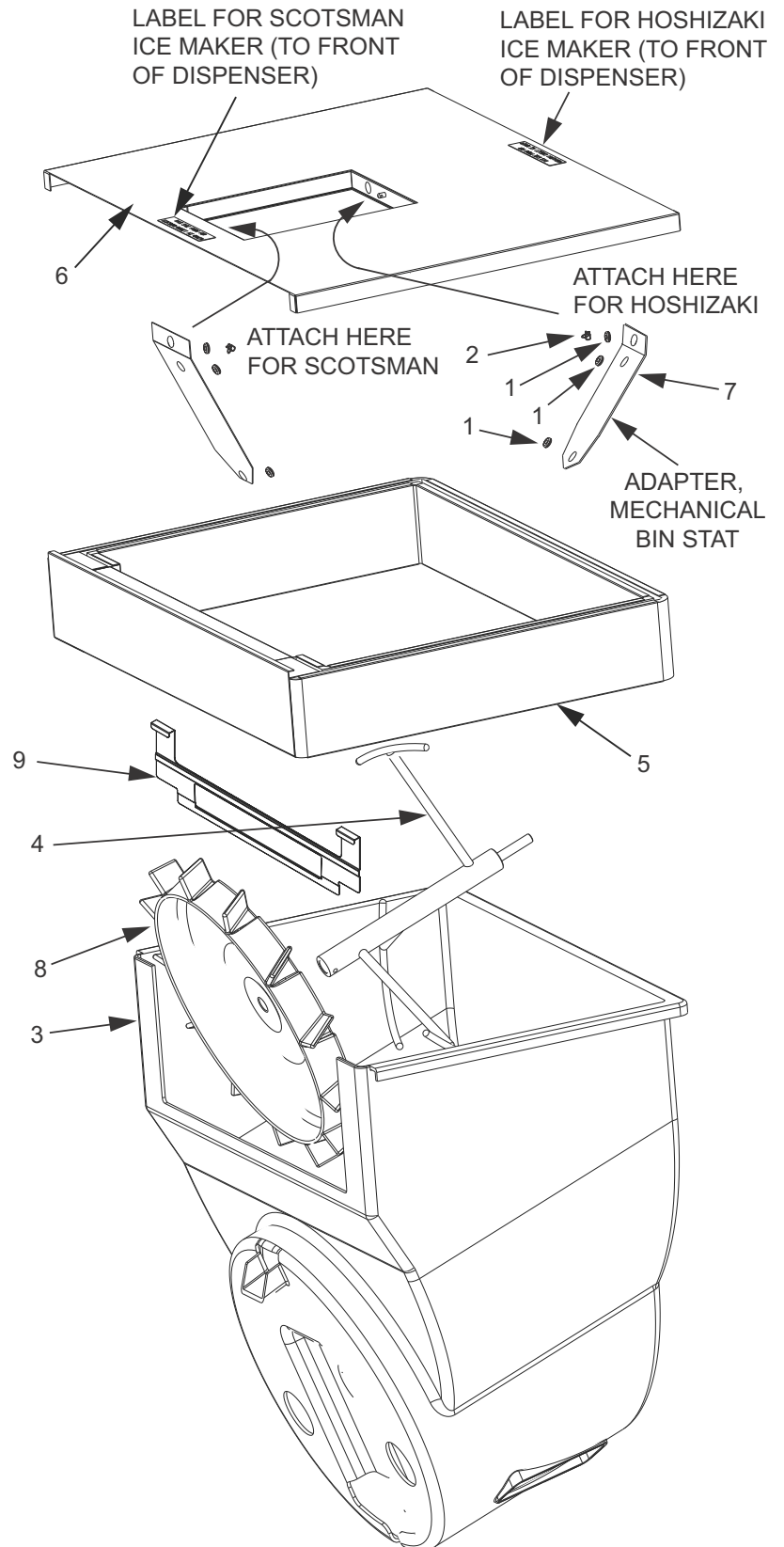

T&S Water Valve Assembly

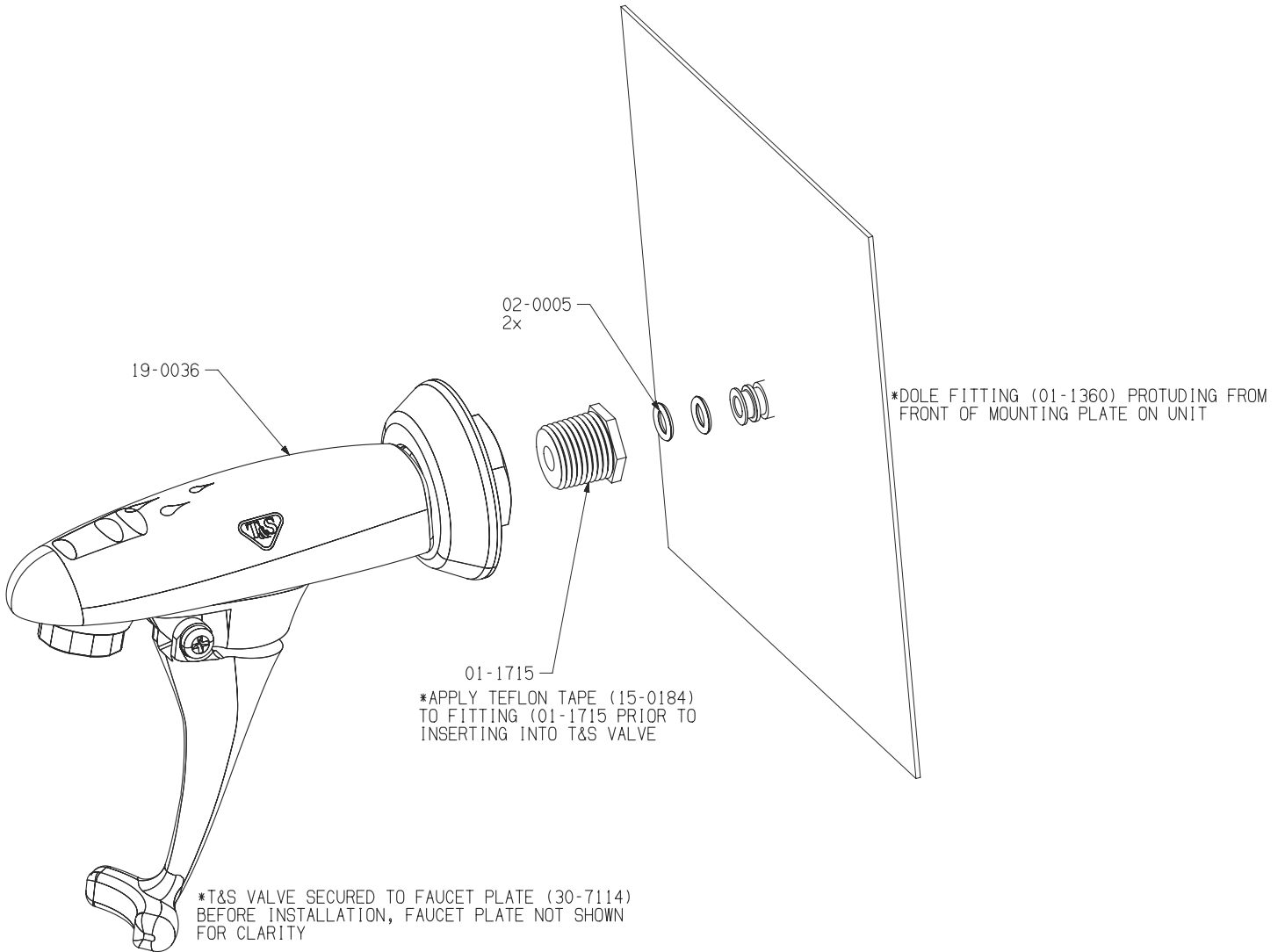

Dispenser Disposal



To prevent possible harm to the environment from improper disposal, recycle the unit by locating an authorized recycler or contact the retailer where the product was purchased. Comply with local regulations regarding disposal of the refrigerant and insulation.

Wiring Diagram - 115 Volt / 60 Hz

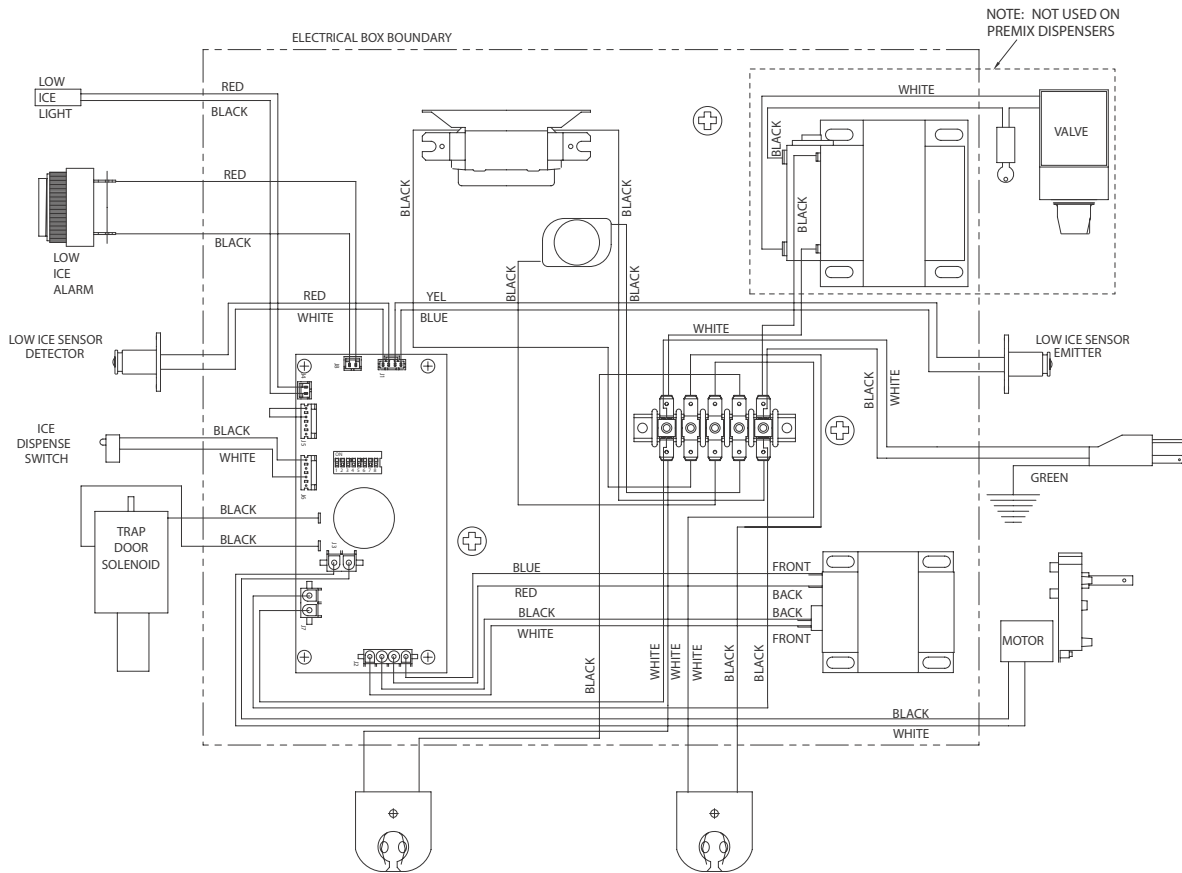

Wiring Diagram - 230 Volt / 50 Hz

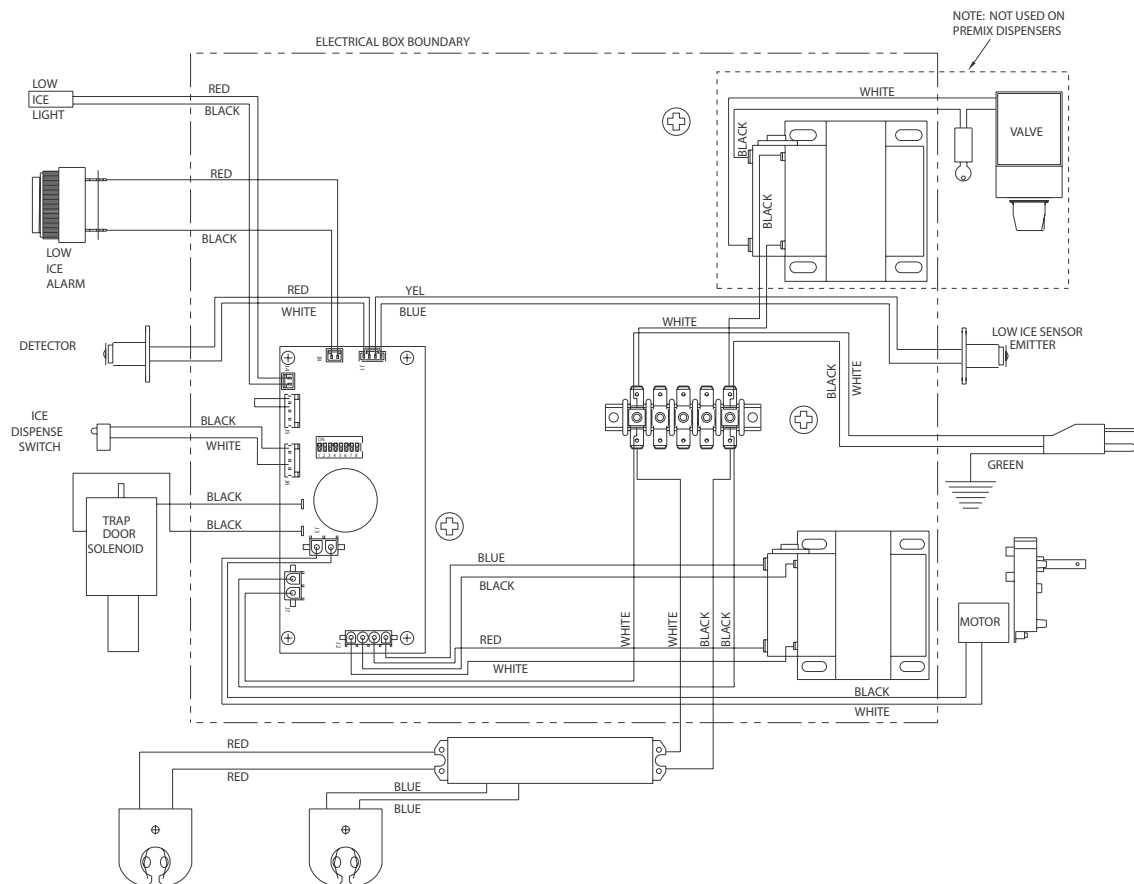

LANCER[®]

Lancer Corp.
800-729-1500
Technical Support/Warranty: 800-729-1550
custserv@lancercorp.com
lancercorp.com