



Ice Cooled Dispenser 1523 Series 2200

Operation Manual

PN: 28-0086/04



Lancer Corp.
6655 Lancer Blvd.
San Antonio, Texas 78219

800-729-1500
Technical Support/Warranty: 800-729-1550
custserv@lancercorp.com
lancercorp.com



Manual PN: 28-0086/04

11/03/97

FOR QUALIFIED INSTALLER ONLY

ABOUT THIS MANUAL

This booklet is an integral and essential part of the product and should be handed over to the operator after the installation and preserved for any further consultation that may be necessary. Please read carefully the guidelines and warnings contained herein as they are intended to provide the user with essential information for the continued safe use and maintenance of the product. In addition, it provides GUIDANCE ONLY to the user on the correct services and site location of the unit.

The installation and relocation, if necessary, of this product must be carried out by qualified personnel with up-to-date safety and hygiene knowledge and practical experience, in accordance with current regulations.

TABLE OF CONTENTS

SPECIFICATIONS.....	3
PRE-INSTALLATION CHECKLIST.....	4
WARNINGS/CAUTIONS.....	5-8
1. INSTALLATION OF LANCER ICE COOLED DISPENSER.....	9
1.1 UNPACKING.....	9
1.2 SELECT A COUNTER LOCATION.....	9
1.3 WATER SUPPLY.....	9
1.4 ELECTRICAL SUPPLY.....	10
1.5 SYRUP CONTAINERS.....	10
1.6 INSTALLATION OF THE UNIT.....	10
1.7 CONNECTION OF THE UNIT.....	11
1.8 START UP.....	11-12
1.9 ADJUSTING WATER FLOW.....	12
1.10 ADJUSTING WATER-TO-SYRUP RATIO (BRIX).....	12
1.11 REPLENISHING SYRUP SUPPLY (5 GALLON TANKS).....	13
2. RECOMMENDED SERVICE AND MAINTENANCE.....	13
2.1 SCHEDULED.....	13
2.2 CLEANING AND SANITIZING SYSTEMS.....	13-14
2.3 CLEANING AND SANITIZING FIGAL SYSTEMS.....	14-15
2.4 CLEANING AND SANITIZING BAG-IN-BOX (BIB) SYSTEMS.....	15-16
2.5 VALVES.....	16
2.6 ICE BIN COMPARTMENT ON ALL ICE CHESTS.....	16
3. TROUBLESHOOTING.....	17
4. DISPENSER DISPOSAL.....	17
5. ILLUSTRATIONS, PARTS LISTINGS, AND WIRING DIAGRAMS.....	19
5.1 LANCER ICE COOLED DISPENSER -- ACCESSORIES.....	19
5.2 SERIES 1500 DROP-IN (PRE-MIX).....	20-21
5.3 SERIES 1500 DROP-IN.....	22-23
5.4 SERIES 1500 PLUG-IN DROP-IN SABRE.....	24-25
5.5 ICE COOLED UNIVERSAL WIRING DIAGRAM WITH BIN LID SWITCH.....	26
5.6 ICE COOLED UNIVERSAL WIRING DIAGRAM WITHOUT BIN LID SWITCH.....	27

ICD 1523 SPECIFICATIONS

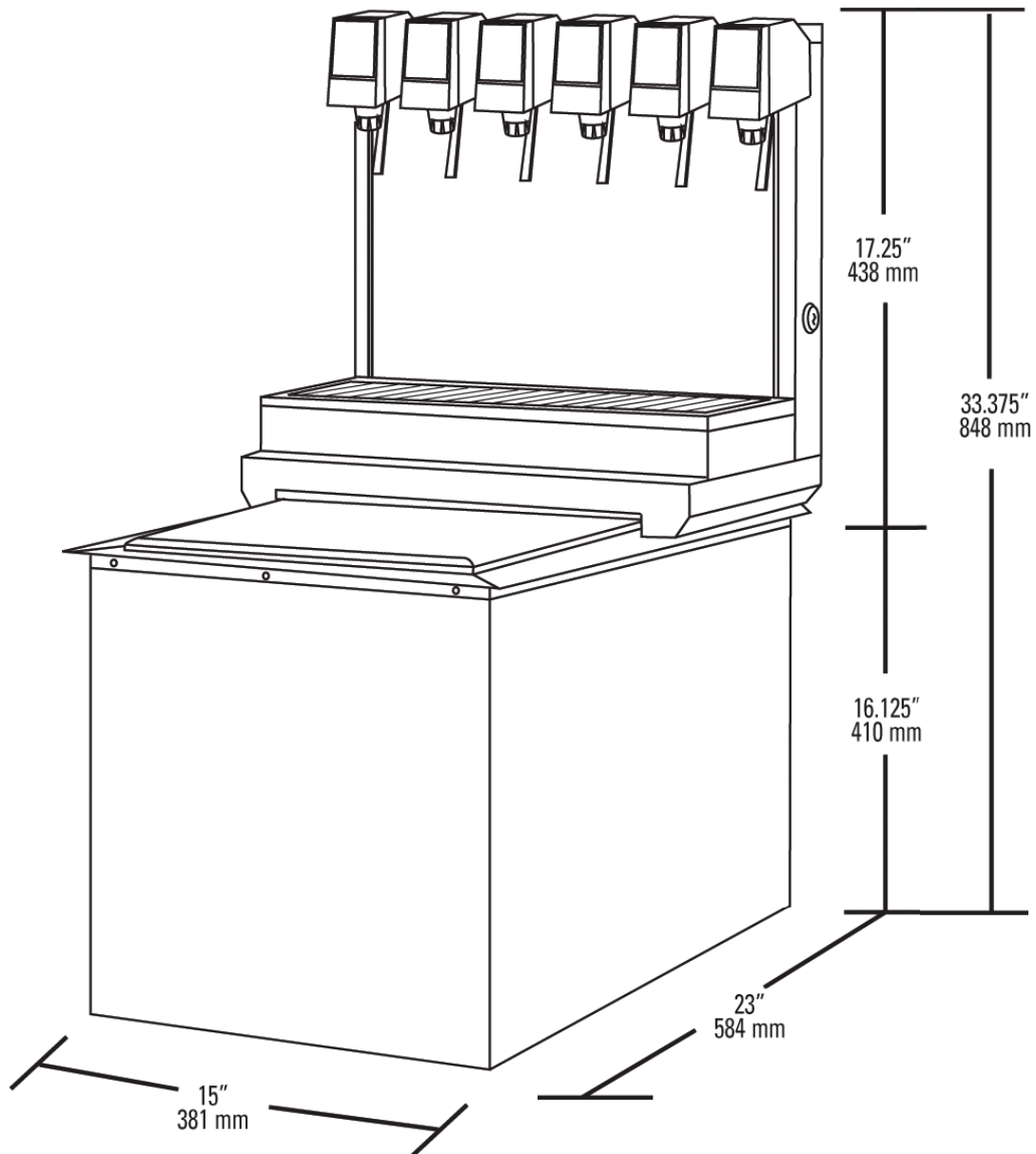

<p>DIMENSIONS Width: 15 inches (381 mm) Depth: 23 inches (584 mm) Height: 33.375 inches (848 mm)</p> <p>COUNTER CUT-OUT Width: 15.25 inches (387 mm) Depth: 23.25 inches (591 mm)</p> <p>ELECTRICAL 115 VAC/ 60 Hz</p>	<p>WEIGHT Operating: 166 lbs (75 kg) Shipping: 130 lbs (59 kg)</p> <p>ICE Capacity: 60 lbs (27.2 kg)</p> <p>FITTINGS Soda water inlet: 3/8" barb Brand syrup inlets: 3/8" barb</p>	<p>PLAIN WATER SUPPLY Min flowing pressure: 20 PSI (0.138 MPA) Max flowing pressure: 50 PSI (0.345 MPA)</p> <p>CARBON DIOXIDE (CO₂) Min pressure: 90 PSIG (0.621 MPA) Max pressure: 110 PSIG (0.758 MPA)</p>
--	---	---

This unit emits a sound pressure level below 70 dB

PRE-INSTALLATION CHECKLIST

BEFORE GETTING STARTED

Each unit is tested under operating conditions and is thoroughly inspected before shipment. At the time of shipment, the carrier accepts responsibility for the unit. Upon receiving the unit, carefully inspect the carton for visible damage. If damage exists, have the carrier note the damage on the freight bill and file a claim with carrier. Responsibility for damage to the dispenser lies with the carrier.

TOOLS REQUIRED	
<input type="checkbox"/> Oetiker Pliers	<input type="checkbox"/> Slotted Screwdriver
<input type="checkbox"/> Tubing Cutters	<input type="checkbox"/> Phillips Screwdriver
<input type="checkbox"/> Wrench	<input type="checkbox"/> Cordless Drill

POST MIX ACCESSORIES	
<input type="checkbox"/> CO2 Regulator Set	<input type="checkbox"/> CO2 Supply
<input type="checkbox"/> Beverage Tubing	<input type="checkbox"/> Oetiker Clamps/Fittings
<input type="checkbox"/> Water Booster	<input type="checkbox"/> Water Regulator
<input type="checkbox"/> Precision Cutters (if removing/replacing carbonator tank)	

BIB SYSTEM	
<input type="checkbox"/> BIB Rack	<input type="checkbox"/> BIB Regulator Set
<input type="checkbox"/> BIB Syrup Boxes	
<input type="checkbox"/> BIB Connectors - ensure you have the correct connectors for syrup lineup.	

CONSIDER LOCATION OF THE FOLLOWING PRIOR TO INSTALL	
<input type="checkbox"/> Water supply lines	<input type="checkbox"/> Drain
<input type="checkbox"/> Is the countertop level?	<input type="checkbox"/> Heating and air conditioning ducts
<input type="checkbox"/> Grounded electrical outlet.	
<input type="checkbox"/> Enough space to install the dispenser. Include space for a top-mounted ice machine, if necessary.	
<input type="checkbox"/> Does the top-mounted ice machine have a minimum clearance on all sides?	
<input type="checkbox"/> Located away from direct sunlight or overhead lighting.	
<input type="checkbox"/> Can the countertop support the weight of the dispenser? Be sure to include the weight of an ice machine (if necessary) plus the weight of the ice.	
<input type="checkbox"/> This unit is not suitable for use in an area where a water jet could be used.	



WARNING/ADVERTENCIA/AVERTISSEMENT



⚠ The dispenser is for indoor use only. This unit is not a toy. Children should not be supervised not to play with appliance. It should not be used by children or infirm persons without supervision. This appliance is not intended for use by persons (including children) with reduced physical, sensory or mental capabilities, or lack of experience and knowledge, unless they have been given supervision or instruction concerning use of the appliance by a person responsible for their safety. Cleaning and user maintenance shall not be performed by children without supervision. This unit is not designed to dispense dairy products. The min/max ambient operating temperature for the dispenser is 40°F to 90°F (4°C to 32°C). Do not operate unit below minimum ambient operation conditions. Should freezing occur, cease operation of the unit and contact authorized service technician. Service, cleaning and sanitizing should be accomplished only by trained personnel. Applicable safety precautions must be observed. Instruction w!arnings on the product being used must be followed.

⚠ El dispensador sólo debe usarse en interiores. Esta unidad no es un juguete. Los niños deben ser supervisados para no jugar con aparato. No la deben usar niños ni personas discapacitadas sin supervisión. Esta unidad no está destinada al uso por parte de personas (incluso niños) con capacidad física, sensorial o mental reducida, o sin experiencia y conocimientos suficientes, a menos que una persona responsable de su seguridad les haya dado supervisión o capacitación en el uso de la unidad. Limpieza y mantenimiento de usuario no deberá ser realizada por los niños sin supervisión. Esta unidad no ha sido diseñada para suministrar productos lácteos. La temperatura ambiente operativa mínima / máxima para el dispensador es de 40°F a 90°F (4°C a 32°C). No opere la unidad debajo de las condiciones de funcionamiento ambientales mínimos. En caso de congelación se produce, cesar la operación de la unidad y el contacto técnico de servicio autorizado. Servicio de limpieza y desinfección deben llevarse a cabo solamente por personal capacitado. Es necesario tomar medidas de seguridad aplicables. Advertencias de las instrucciones sobre el producto utilizado se deben seguir.

⚠ Le distributeur est destiné à un usage à l'intérieur seulement. Cet appareil n'est pas un jouet. Les enfants doivent être surveillés afin de ne pas jouer avec l'appareil. Il ne devrait pas être utilisé par des enfants ou des personnes infirmes sans surveillance. Cet appareil n'est pas destiné à un usage par des personnes (y compris les enfants) ayant des capacités physiques, sensorielles ou mentales réduites, ou manquant d'expérience et de connaissances, à moins qu'elles obtiennent de la surveillance ou des instructions au sujet de l'utilisation de l'appareil de la part d'une personne chargée de leur sécurité. Nettoyage et entretien de l'utilisateur ne doivent pas être effectués par des enfants sans surveillance. Cet appareil n'est pas conçu pour distribuer des produits laitiers. La température de service ambiante minimum/maximum pour le distributeur est de 40°F à 90°F (4°C à 32°C). Ne pas utiliser l'appareil dans des conditions de performance environnementale minimale. En cas de gel, cesser l'exploitation de l'unité et contactez un technicien agréé. Nettoyage et désinfection doivent être effectuées uniquement par du personnel qualifié. Vous devez prendre des mesures de sécurité. Avertissements instructions sur le produit utilisé doivent être respectées.



DISPENSER INSTALLATION HIGHLIGHTS



This unit has been factory sanitized per Lancer specifications.

Listed below are six critical elements which will aid in a successful installation.

1. Fill water bath until water overflows from tank overflow tube.
2. The carbonator pump motor must be disconnected from the power supply prior to connection to water supply for initial build up of ice bank. Failure to do so will result in automatic shut off of carbonator (see item 6 below) or damage to the pump.
3. If this dispenser is installed in an area that is susceptible to $\pm 10\%$ variation of the nominal line voltage, consider installing a surge protector or similar protection device.
4. There is a five (5) minute delay which prevents the compressor and condenser fan from starting until the delay has lapsed. If electrical current is interrupted, there is always a five (5) minute delay before the compressor starts.
5. Supply Water Pressure: Minimum - 20 PSI (0.138 MPA); Maximum - 50 PSI (0.345 MPA); If pressure is over 50 PSIG (0.345 MPA), a water pressure regulator must be used.
6. On units with the built in water regulator, the regulator must be removed if inlet water pressure is less than 20 PSIG. (0.138 MPA)



PUNTOS IMPORTANTES EN LA UNIDAD DISPENSADORA



Esta unidad ha sido saneada en fabrica por las especificaciones de Lancer.

A continuacion se relacionan 6 puntos importantes para una correcta instalacion.

1. Llene el bano-Maria hasta que el agua se desborde sobre el tubo que controla la derrama del tanque.
2. El motor de la bomba del carbonatador debe desconectarse electricamente antes de conectar el suministro de agua para la formacion inicial del banco de hielo. De no hacerse esto resultaria en un bloqueo automatico del carbonatador (ver abajo el punto 6) o en danos a la bomba.
3. Si la unidad va a ser instalada en un area en la que puedan darse variaciones de voltage de + 6 - 10% de su valor nominal, se debe considerar la conveniencia de instalar un estabilizador de corriente o sistema de proteccion similar.
4. Hay una demora de 5 minutos que evita que el compresor y el abanico del condensador arranquen hasta pasado ese tiempo. Si hay algun corte en la corriente electrica siempre se producira esa demora de 5 minutos antes de arrancar el compresor.
5. Presión de suministro del agua de red: Minimo 20 PSI (0.138 MPA); Maximo 50 PSI (0.345 MPA). En unidades sin regulador de presión incorporado, si la presión del agua es superior a 50 PSIG (0.345 MPA) se debe usar un regulador de presión.
6. En unidades con regulador de presión incorporado, el regulador debe ser eliminado cuando la presión de entrada de agua sea inferior a 20 PSIG (0.138 MPA).



REGLES DE SECURITE POUR L'INSTALLATION DU DISTRIBUTEUR DE SODAS



La propreté de cet ensemble est assuré à l'usine suivant les spécifications émis par Lancer .

Il est essentiel de respecter les 6 points suivants pour l'installation de l'appareil:

1. Remplir le bain-Maire jusqu'à ce que l'eau déborde par le tuyau de trop-plein du réservoir.
2. Le moteur de la pompe du carbonateur doit être débranché de l'alimentation électrique avant l'arrivée de l'eau pour la formation initiale de la glace. Oublier ou négliger cette opération provoquera l'arrêt automatique du carbonateur (voir le point 6 cidessous) ou causera des dommages à la pompe.
3. Si le distributeur est installé dans une zone où la tension électrique nominale est susceptible de variations de (+) 10%, il est conseillé d'installer un appareil de protection contre les sautes de courant.
4. Un délai de 5 minutes empêche le compresseur et la ventilation du condenseur de se mettre en marche avant que ce laps de temps ne se soit écoulé. Lorsque le courant électrique est interrompu, il y a toujours un délai de 5 minutes avant que le presseur ne se mette en.
5. Pression de l'eau: Minimum 20 PSI (0.138 MPA); Maximo 50 PSI (0.345 MPA). Sur les unités qui n'ont pas de régulateur de pression d'eau incorporé, si la pression d'H₂O est supérieure à 50 PSIG (0.345 MPA), un régulateur de pression d'eau doit être utilisé.
6. Sur les unités avec régulateur d'eau incorporé, le régulateur doit être enlevé si la pression d'arrivée est inférieure à 20 PSIG (0.138 MPA)



ELECTRICAL WARNING/ADVERTENCIA ELÉCTRICA/ AVERTISSEMENT ÉLECTRIQUE



⚠ Check the dispenser serial number plate for correct electrical requirements of unit. Do not plug into a wall electrical outlet unless the current shown on the serial number plate agrees with local current available. Follow all local electrical codes when making connections. Each dispenser must have a separate electrical circuit. Do not use extension cords with this unit. Do not 'gang' together with other electrical devices on the same outlet. The keyswitch does not disable the line voltage to the transformer primary. Always disconnect electrical power to the unit to prevent personal injury before attempting any internal maintenance. The resettable breaker switch should not be used as a substitute for unplugging the dispenser from the power source to service the unit. Only qualified personnel should service internal components of electrical control housing. Make sure that all water lines are tight and units are dry before making any electrical connections!

⚠ Verifique la placa con el número de serie del dispensador, donde encontrará los requisitos eléctricos correctos de la unidad. No enchufe la unidad en un tomacorriente de pared a menos que la corriente indicada en la placa con el número de serie concuerde con la corriente local disponible. Al hacer las conexiones, respete todos los códigos eléctricos locales. Cada dispensador debe tener un circuito eléctrico independiente. No use extensiones con esta unidad. No la conecte junto con otros dispositivos eléctricos al mismo tomacorriente. El interruptor de llave no corta el voltaje de línea al transformador primario desconecte siempre la alimentación eléctrica a la unidad para evitar lesiones personales antes de tratar de realizar tareas de mantenimiento. El disyuntor de sobrecarga reseteable no se debe usar como sustituto para desenchufar el dispensador de la fuente de alimentación para realizar tareas de servicio de la unidad. El servicio de los componentes internos de la caja de control eléctrico debe confiarse exclusivamente a personal calificado. Asegúrese de que todas las líneas de agua estén ajustadas y las unidades estén secas antes de hacer conexiones eléctricas.

⚠ Examinez la plaque de numéro de série du distributeur pour connaître les bonnes exigences en matière d'électricité pour l'appareil. Ne le branchez pas à une prise électrique murale à moins que le courant indiqué sur la plaque de numéro de série corresponde au courant local disponible. Respectez tous les codes électriques locaux lorsque vous faites des connexions. Chaque distributrice doit avoir un circuit électrique séparé. N'utilisez pas de cordons prolongateurs avec cet appareil. Ne pas le brancher avec d'autres appareils électriques sur la même prise. L'interrupteur à clé ne coupe pas la tension secteur au transformateur primaire. Débranchez toujours le courant électrique à l'appareil, afin de prévenir des blessures, avant de faire un entretien interne quelconque. Le disjoncteur réarmable ne devrait pas être utilisé au lieu de débrancher le distributeur de la source d'alimentation en électricité pour faire de l'entretien/une réparation de l'appareil. Seul le personnel qualifié devrait faire l'entretien/la réparation des composants internes dans le logement des commandes électriques. Assurez-vous que toutes les conduites d'eau sont étanches et que les appareils sont secs avant de faire des connexions électriques!



CO₂/CARBON DIOXIDE /EI ANHÍDRIDO CARBÓNICO/ DIOXYDE DE CARBONE



⚠ Carbon Dioxide (CO₂) is a colorless, noncombustible gas with a light pungent odor. High percentages of CO₂ may displace oxygen in the blood. Prolonged exposure to CO₂ can be harmful. Personnel exposed to high concentrations of CO₂ gas will experience tremors which are followed by a loss of consciousness and suffocation. If a CO₂ gas leak is suspected, immediately ventilate the contaminated area before attempting to repair the leak. Strict attention must be observed in the prevention of CO₂ gas leaks in the entire CO₂ and soft drink system.

⚠ El anhídrido carbónico (CO₂) es un gas incoloro, no combustible, con un olor pungente ligero. Altos porcentajes de CO₂ en la sangre pueden desplazar el oxígeno en la sangre. La exposición prolongada al CO₂ puede ser nociva. El personal expuesto a concentraciones altas de CO₂ sufre temblores seguidos de la pérdida de la consciencia y sofocación. Si se sospecha que existe una pérdida de CO₂, ventile el área contaminada antes de tratar de reparar la pérdida. Hay que prestar suma atención para evitar pérdidas de CO₂ en todo el sistema de CO₂ y de bebidas gaseosas.

⚠ Le dioxyde de carbone (CO₂) est plus lourd que l'air et déplace l'oxygène. Le CO₂ est un gaz incolore et incombustible, ayant une odeur un peu âcre. Des concentrations fortes de CO₂ peuvent déplacer l'oxygène dans le sang. Une exposition prolongée au CO₂ peut être nocive. Le personnel exposé à de fortes concentrations de CO₂ gazeux éprouvera des tremblements, suivis rapidement d'une perte de conscience et de suffocation. On doit faire très attention de prévenir les fuites de CO₂ gazeux dans le système entier de CO₂ et de boisson gazeuse. Si on suspecte qu'il y a une fuite de CO₂ gazeux, aérez le secteur contaminé immédiatement avant d'essayer de réparer la fuite.



AUTOMATIC AGITATION/AGITACIÓN AUTOMÁTICA/



⚠ Units are equipped with an automatic agitation system and will activate unexpectedly. Do not place hands or foreign objects in the water bath tank. Unplug the dispenser during servicing, cleaning, and sanitizing. To avoid personal injury, do not attempt to lift the dispenser without assistance. For heavier dispensers, use a mechanical lift.

⚠ Las unidades están equipadas con un sistema automático de agitación, por lo que se pueden activar repentinamente. No ponga las manos ni objetos extraños en el compartimiento donde se guarda el hielo. Durante el servicio, la limpieza y la esterilización, desenchufe el dispensador. Para evitar lesiones personales, no trate de levantar el dispensador sin ayuda. Para los dispensadores más pesados, use un elevador mecánico.

⚠ Les appareils sont équipés d'un système d'agitation automatique qui s'activera de manière inattendue. Ne mettez pas les mains ou des corps étrangers dans le compartiment d'entreposage de glace. Débranchez le distributeur pendant l'entretien/la réparation, le nettoyage et l'aseptisation. Pour éviter des blessures, n'essayez pas de soulever le distributeur sans aide. Pour les distributeurs plus lourds, utilisez un chariot élévateur.



WATER NOTICE/AGUA AVISO/ PRÉAVIS DE L'EAU



⚠ Provide an adequate potable water supply. Water pipe connections and fixtures directly connected to a potable water supply must be sized, installed, and maintained according to federal, state, and local laws. The water supply line must be at least a 3/8 inches (9.525 mm) pipe with a minimum of 20 PSI (0.138 MPA) line pressure, but not exceeding a maximum of 50 PSI (0.345 MPA). Water pressure exceeding 50 PSI (0.345 MPA) must be reduced to 20 PSI (0.138 MPA) with the provided pressure regulator. Use a filter in the water line to avoid equipment damage and beverage off-taste. Check the water filter periodically, as required by local conditions. The water supply must be protected by means of an air gap, a backflow prevention device (located upstream of the CO2 injection system) or another approved method to comply with NSF standards. A leaking inlet water check valve will allow carbonated water to flow back through the pump when it is shut off and contaminate the water supply. Ensure the backflow prevention device complies with ASSE and local standards. It is the responsibility of the installer to ensure compliance.

⚠ Proporcione un suministro adecuado de agua potable. La línea de suministro de agua debe ser de una tubería de por lo menos 3/8 pulgadas (9.525 mm) con una presión de línea mínima de 20 PSI (0.138 MPA), pero sin superar el máximo de 50 PSI (0.345 MPA). La presión de agua que supere los 50 PSI (0.345 MPA) se debe reducir a 20 PSI (0.138 MPA) con un regulador de presión. Use un filtro en la línea de agua para evitar daños al equipo y cierto sabor raro en las bebidas. Verifique periódicamente el filtro de agua de acuerdo con las condiciones imperantes. El suministro de agua debe estar protegido por una separación de aire, un dispositivo de prevención del contraflujo (situado antes del sistema de inyección de CO2) u otro método aprobado para cumplir las normas NSF. Si la válvula de retención de entrada de agua tuviera pérdidas, permitiría el contraflujo del agua carbonatada a través de la bomba cuando se la detiene y contaminaría el suministro de agua. Asegúrese de que el dispositivo de prevención del contraflujo cumpla con las normas locales y de ASSE. Es responsabilidad del instalador cumplir con estos requisitos.

⚠ Fournissez une alimentation en eau potable adéquate. Les connexions et les dispositifs de conduite d'eau connectés directement à une alimentation en eau potable doivent être calibrés, installés et maintenus selon les lois fédérales, provinciales et locales. La conduite d'alimentation en eau doit être un tuyau d'au moins 3/8 pouces (9.525 millimètres) avec une pression de ligne minimum de 20 LPC (0.138 MPA), mais ne doit pas dépasser un maximum de 50 LPC (0.345 MPA). Une pression d'eau de plus de 50 LPC (0.345 MPA) doit être réduite à 20 LPC (0.138 MPA) avec le régulateur de pression fourni. Utilisez un filtre dans la conduite d'eau pour éviter des dommages à l'équipement et un goût des boissons qui n'est pas juste. Vérifiez le filtre à eau périodiquement, selon les exigences des conditions locales. L'alimentation en eau doit être protégée au moyen d'un intervalle d'air, un disconnecteur hydraulique (situé en amont du système d'injection de CO2) ou une autre méthode approuvée pour se conformer aux normes de la NSF. Un clapet antiretour pour l'eau entrante qui fuie permettra à l'eau gazeuse de repasser par la pompe quand elle est fermée et de contaminer l'alimentation en eau. Assurez-vous que le disjoncteur hydraulique soit conforme aux normes de l'ASSE et locales. L'installateur est responsable d'assurer la conformité.

1. INSTALLATION OF LANCER ICE COOLED DISPENSER

1.1 UNPACKING

- A. The Lancer Ice Cooled Dispenser is shipped in a corrugated shipping carton.
- B. Carefully remove the corrugated shipping carton from the unit.
- C. Remove parts from the Ice Compartment.
- D. Inspect unit for concealed damage(s). If evident, notify delivering carrier and file a claim against same.

1.2 SELECTING A COUNTER LOCATION

- A. Select a counter location which is close to a properly grounded electrical outlet, and a water supply that meets the requirements specified in Section 1.4 below.
- B. Counter location must be able to safely support a minimum of 225 pounds (102.3 kg) after counter cutout is made.

1.3 WATER SUPPLY

	<p>CAUTION FAILURE TO LIMIT WATER PRESSURE TO 50 PSI (0.345 MPA) WILL RESULT IN IMPROPER PERFORMANCE OF THE DISPENSER.</p> <p>PRECAUCIÓN FALTA DE LIMITAR LA PRESIÓN DE AGUA PARA 50 PSI (0.345 MPA) DARÁ LUGAR A LA MALA EJECUCIÓN DEL DISPENSADOR.</p> <p>ATTENTION DÉFAUT DE LIMITER LA PRESSION DE L'EAU A 50 PSI (0,345 MPA) ENTRAÎNERA LA MAUVAISE EXÉCUTION DU DISTRIBUTEUR.</p>
---	--

- A. An adequate potable water supply must be provided. The water supply line must be at least a 3/8 inch pipe with a minimum of 20 PSI (0.138 MPA) line pressure, but not exceeding a maximum of 50 PSI (0.345 MPA). Water pressure exceeding 50 PSI (0.345 MPA) must be reduced to 50 PSI 0.345 MPA) with a pressure regulator.

	<p>CAUTION A FILTER IN THE WATER LINE MUST BE USED IF THE WATER SUPPLY CONTAINS ANY APPRECIABLE AMOUNT OF SILT, SAND, OR ANY OTHER DEBRIS. FAILURE TO DO SO CAN RESULT IN EQUIPMENT DAMAGE.</p> <p>PRECAUCIÓN UN FILTRO EN LA TUBERÍA DE AGUA DEBE SER USADO SI EL SUMINISTRO DE AGUA CONTIENE UNA CANTIDAD APRECIABLE DE CIENO, ARENA, CUALQUIER OTRO DESPERDICIO. NO HACERLO PUEDE PROVOCAR DAÑOS AL EQUIPO.</p> <p>ATTENTION UN FILTRE DANS LA CONDUITE D'EAU DOIT ÊTRE UTILISÉE SI L'APPROVISIONNEMENT EN EAU CONTIENT UNE QUANTITÉ APPRÉCIABLE DE LIMON, DE SABLE, OU TOUTE AUTRE DÉBRIS. PANNE DE LE FAIRE PEUT PROVOQUER DES DOMMAGES MATÉRIELS..</p>
---	---

- B. The Carbonator Pump is equipped with a Strainer and a Tee on the outlet side for a plain water Valve (if required), but a water supply containing any appreciable quantity of silt, fine sand, or other debris requires a Filter ahead of the Unit. The Filter cartridge must be cleaned periodically, depending upon the condition of the water. Failure to do so may starve the Pump and cause it to burn out; thereby, voiding the equipment warranty

1.4 ELECTRICAL SUPPLY



GROUNDING WARNING THE DISPENSER MUST BE PROPERLY ELECTRICALLY GROUNDED TO AVOID SERIOUS INJURY OR FATAL ELECTRICAL SHOCK. THE POWER CORD HAS A THREE-PRONG GROUNDED PLUG. IF A THREE-HOLE GROUNDED ELECTRICAL OUTLET IS NOT AVAILABLE, USE AN APPROVED METHOD TO GROUND THE UNIT. FOLLOW ALL LOCAL ELECTRICAL CODES WHEN MAKING CONNECTIONS. EACH DISPENSER MUST HAVE A SEPARATE ELECTRICAL CIRCUIT. DO NOT USE EXTENSION CORDS. DO NOT CONNECT MULTIPLE ELECTRICAL DEVICES ON THE SAME OUTLET.

ADVERTENCIA, PUESTA A TIERRA ES NECESARIO PONER A TIERRA ELÉCTRICAMENTE EL DISPENSADOR PARA EVITAR LESIONES GRAVES E INCLUSO ELECTROCHOQUES FATALES. EL CABLE DE ALIMENTACIÓN TIENE UN ENCHUFE PUESTO A TIERRA DE 3 CLAVIJAS. SI NO SE DISPONE DE UN TOMA ELÉCTRICO CONECTADO A TIERRA DE TRES AGUJEROS, USE UN MÉTODO APROBADO PARA PONER A TIERRA LA UNIDAD. AL HACER LAS CONEXIONES, RESPETE TODOS LOS CÓDIGOS ELÉCTRICOS LOCALES. CADA DISPENSADOR DEBE TENER UN CIRCUITO ELÉCTRICO INDEPENDIENTE. NO USE CABLES DE EXTENSIÓN. NO CONECTE VARIOS DISPOSITIVOS ELÉCTRICOS AL MISMO TOMACORRIENTE.

EXIGENCES DE MISE À LA TERRE LA DISTRIBUTRICE DOIT ÊTRE MISE À LA TERRE ÉLECTRIQUEMENT CORRECTEMENT POUR ÉVITER DES BLESSURES GRAVES OU UNE DÉCHARGE ÉLECTRIQUE MORTELLE. LE CORDON D'ALIMENTATION A UNE FICHE À TROIS BRANCHES MISE À LA TERRE. SI AUCUNE PRISE DE COURANT ÉLECTRIQUE À TROIS TROUS N'EST DISPONIBLE, UTILISEZ UNE MÉTHODE APPROUVÉE POUR METTRE L'UNITÉ À LA TERRE. RESPECTEZ TOUS LES CODES ÉLECTRIQUES LOCAUX LORSQUE VOUS FAITES DES CONNEXIONS. CHAQUE DISTRIBUTRICE DOIT AVOIR UN CIRCUIT ÉLECTRIQUE SÉPARÉ. N'UTILISEZ PAS DE CORDONS PROLONGATEURS. NE BRANCHEZ PAS PLUSIEURS APPAREILS ÉLECTRIQUES À LA MÊME PRISE DE COURANT.

- A. A standard 15 AMP, 110 VAC, 60 Hz, single phase electrical power outlet with a ground connector should be provided for the operation of the unit

1.5 SYRUP CONTAINERS

- A. When the unit is used in the Coca-Cola Company installations, the syrup containers are to be attached as outlined in the appropriate Coca-Cola Company Service Manual.
- B. For other installations, the syrup containers (sold as an accessory) are of stainless steel construction with a capacity of five gallons. They are equipped with a CO₂ gas quick disconnect fitting and a syrup quick disconnect fitting. The standard syrup outlet is a 1/4 inch (6.35 mm) male flare (MF). A low pressure regulator manifold (an accessory) may be mounted on the wall above the syrup tanks.
- C. The inlets on the unit, located on the right rear of the machine, are tagged (or coded) to the proper valves. When making the connection to these inlets, provide a good, leak tight joint to prevent twisting the tubing.

1.6 INSTALLATION OF THE UNIT

- A. Inspect the counter location where the unit is to be installed. Verify that the counter is strong enough to safely support a 225 pound (102.3 kg) load, after the cutout for the unit is made.
- B. Verify that the unit will fit in the desired location. See Figure 1 for the footprint and counter cutout for the unit.

NOTE: Remember that the unit can extend up to 23 inches (58.42 cm) below the counter, including the shipping risers, which Lancer recommends be left attached to the unit. Should the dispenser ever require removal, the shipping risers will protect the inlet tubes from being damaged.

- C. After the counter cutout is complete, the unit may be lowered into the counter.

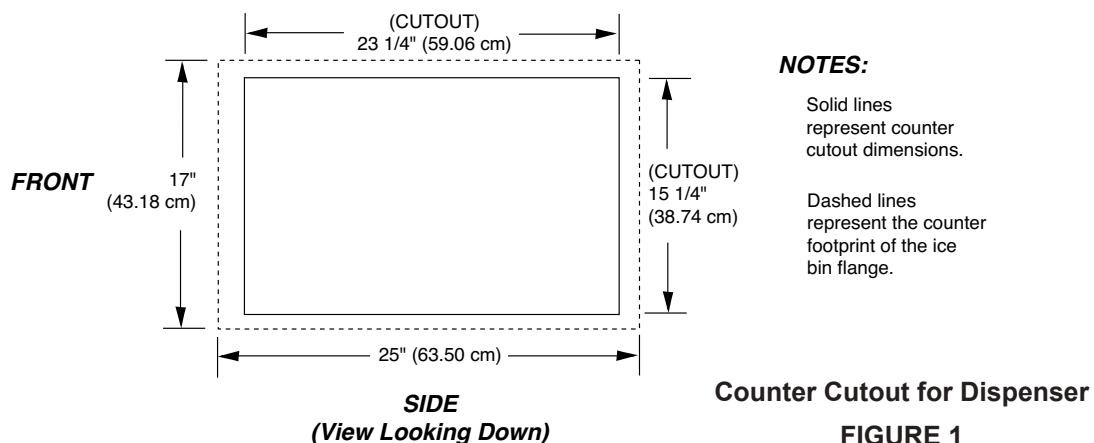

1.7 CONNECTION OF THE UNIT

- A. Position the CO2 gas tank in the desired location. Assemble the high pressure regulator to the CO2 gas tank and run jumper line to low pressure regulator.
- B. Attach the CO2 gas line to the carbonator by attaching the line from the high pressure regulator to the single check valve marked "gas" on top of the Carbonator Tank. The setting of the high pressure CO2 gas Regulator should be 90 PSI (0.621 MPA) to 110 PSI (0.758 MPA).



WARNING DO NOT TURN ON THE CO2 SUPPLY AT THIS TIME.

ADVERTENCIA NO CONECTE TODAVÍA LA ALIMENTACIÓN DE CO2.

AVERTISSEMENT N'OUVREZ PAS L'ALIMENTATION EN CO2 À CE MOMENT.

- C. Position the syrup tanks in the desired location. Attach the CO2 gas lines leading from the low pressure regulator to these tanks.
- D. Connect syrup lines from tanks to the appropriate inlets at the right front of the unit. The syrup inlets are identified.



CAUTION A FILTER IN THE WATER LINE MUST BE USED IF THE WATER SUPPLY CONTAINS ANY APPRECIABLE AMOUNT OF SILT, SAND, OR ANY OTHER DEBRIS. FAILURE TO DO SO CAN RESULT IN EQUIPMENT DAMAGE.

PRECAUCIÓN UN FILTRO EN LA TUBERÍA DE AGUA DEBE SER USADO SI EL SUMINISTRO DE AGUA CONTIENE UNA CANTIDAD APRECIABLE DE CIEÑO, ARENA, CUALQUIER OTRO DESPERDICIO. NO HACERLO PUEDE PROVOCAR DAÑOS AL EQUIPO.

ATTENTION UN FILTRE DANS LA CONDUITE D'EAU DOIT ÊTRE UTILISÉE SI L'APPROVISIONNEMENT EN EAU CONTIENT UNE QUANTITÉ APPRÉCIABLE DE LIMON, DE SABLE, OU TOUTE AUTRE DÉBRIS. PANNE DE LE FAIRE PEUT PROVOQUER DES DOMMAGES MATÉRIELS..

- E. Mount the water filter assembly (if required) and water regulator (if required) in a convenient location.



CAUTION FAILURE TO LIMIT WATER PRESSURE TO 50 PSI (0.345 MPA) WILL RESULT IN IMPROPER PERFORMANCE OF THE DISPENSER.

PRECAUCIÓN FALTA DE LIMITAR LA PRESIÓN DE AGUA PARA 50 PSI (0.345 MPA) DARÁ LUGAR A LA MALA EJECUCIÓN DEL DISPENSADOR.

ATTENTION DÉFAUT DE LIMITER LA PRESSION DE L'EAU A 50 PSI (0,345 MPA) ENTRAÎNERA LA MAUVAISE EXÉCUTION DU DISTRIBUTEUR.

- F. Connect the water inlet line to the water regulator (if required), water filter (if required), and then to the water inlet of the carbonator pump on the carbonator.
- G. Provide a suitable drain in the plumbing system and attach the one (1) inch (2.54 cm) diameter schedule 40 PVC drains to the drain. The drip pan drainage outlet is located at the center rear of the unit. The ice water drainage outlet is located at the right front of the unit
- H. Be sure to place the ice trap in the drain outlet inside the ice bin before filling the cabinet with ice. This device holds the ice away from the drain outlet, allowing the ice water to drain properly.
- I. Plug in the transformer box to a standard 15 AMP, 110 VAC, single phase outlet. The unit will internally convert 110 VAC electricity to 24 VAC.

1.8 START UP

- A. After all connections to water, CO2 gas, electrical power, and syrup containers are made, check for leaks.
- B. Check to insure that syrup tanks contain syrup.



CAUTION DO NOT OPERATE CARBONATOR PUMP WITH WATER SUPPLY SHUT OFF.

PRECAUCIÓN NO HAGA FUNCIONAR LA BOMBA CARBONATADOR CON SUMINISTRO DE AGUA CIERRE.

ATTENTION NE PAS FAIRE FONCTIONNER LA POMPE DE CARBONATEUR L'APPROVISIONNEMENT EN EAU COUPÉE.

- C. Turn water ON. Open the pressure relief valve on the carbonator tank by lifting the wire ring, and hold it open until water flows from the relief valve. Close the relief valve and turn on the CO2 gas and electrical power in that order.
- D. To fill all lines with water, cycle the carbonator several times by operating the dispersing valves.
 - 1. A low pressure gas regulator controls the flow of syrup to each dispensing valve. For proper operation of the valves, the pressure regulator should be set so that 40 PSI is at the back block of the valve.
 - 2. For diet type syrup, the tank pressures should be set at 10 PSI, or as recommended by the syrup supplier. Additional pressure may be necessary, depending on the distance from the syrup tank to the unit.
- E. Fill unit with ice cubes to the level of the door opening at this time.

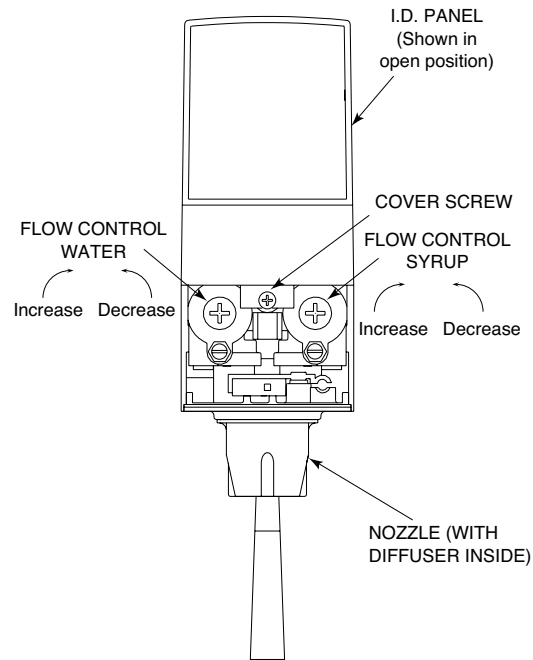

Valve Adjustments

FIGURE 2

1.9 ADJUSTING WATER FLOW

- A. The water flow can be adjusted to either 1.25 oz/sec (37 ml/sec) or 2.50 oz/sec(74 ml/sec) on all dispensing valves by using the following procedure.
- B. The unit should have ice on the cold plate for at least one hour before attempting to BRIX the valves. The drink temperature should be no higher than 40°F (4.4°C) when the ratio is set. This is done after the unit has ice in the ice bin.
- C. Slide the ID panel UP until the flow controls are exposed (see Figure 2).
- D. Remove the nozzle by turning the nozzle counter clockwise and pulling down.
- E. Remove the diffuser by pulling the diffuser in a downward motion.
- F. Install the Lancer (yellow) syrup separator (PN 54-0031) in place of the nozzle.
- G. Activate dispensing valve to fill the separator syrup tube.
- H. Hold a Lancer BRIX cup (PN 05-0090) under the syrup separator and dispense water and syrup into the BRIX cup for four (4) seconds. Divide the number of ounces (ml) of water in the cup by four (4) to determine the water flow rate per second.
- I. To obtain the proper flow, use a screwdriver to adjust water flow control (see Figure 2).
- J. Repeat this process for each valve.

1.10 ADJUSTING WATER-TO-SYRUP RATIO (BRIX)

- A. Hold the Lancer ratio cup under the syrup separator and activate valve. Check ratio (BRIX).
- B. To obtain the proper ratio, use screw-driver to adjust syrup flow control (see Figure 2).
- C. Remove syrup separator.
- D. Install diffuser and nozzle.
- E. Slide ID panel DOWN.
- F. Repeat this process for each valve.

NOTE: In all cases of re-assembly of valves involving o-rings, be sure the o-ring is lubricated with water or an FDA approved lubricant to prevent leakage or damage to the o-ring.

1.11 REPLENISHING SYRUP SUPPLY (5 GALLON TANKS)

- A. The following procedure should be used to add syrup to a tank after the system is in operation.
1. Shut off CO2 gas supply system to syrup tanks.
 2. Snap off the self-sealing quick-coupler. Allow gas in the syrup tank to escape by pulling the outer shell of the quick-coupler toward the flexible line and allowing the whole connection to pull free.

	WARNING TO AVOID POSSIBLE PERSONAL INJURY OR PROPERTY DAMAGE, DO NOT ATTEMPT TO REMOVE SYRUP TANK COVER UNTIL CO2 HAS BEEN RELEASED FROM TANK.
	ADVERTENCIA PARA EVITAR POSIBLES LESIONES PERSONALES O DAÑOS MATERIALES, NO TRATE DE RETIRAR LA TAPA DEL TANQUE DE SOROPE HASTA QUE SE HAYA LIBERADO LA PRESIÓN DEL CO2 DEL TANQUE.
	AVERTISSEMENT POUR ÉVITER DES BLESSURES OU DES DOMMAGES MATÉRIELS POSSIBLES, N'ESSAYEZ PAS DE RETIRER LE COUVERCLE DU RÉSERVOIR DE SIROP, JUSQU'À CE QUE DE LA PRESSION DE CO2 AIT ÉTÉ LIBÉRÉE DU RÉSERVOIR.

3. Remove the cover by pulling upward on the hinged locking bar.
4. Fill tank with appropriate syrup, leaving one (1) inch (2.54 cm) of space for CO2 gas.
5. Replace locking cover insuring that the cover and cover gasket are properly aligned.
6. Snap on quick-coupler and lock it securely in place. Turn CO2 gas pressure ON. When properly connected, the gas will automatically enter the tank with an audible noise.

2. RECOMMENDED SERVICE AND MAINTENANCE

2.1 SCHEDULED

- A. Daily – See Section 2.5 for daily cleaning.
B. Monthly – See Section 2.6 for monthly cleaning.
C. Periodic Sanitizing - See sections 2.2, 2.3, and 2.4 for sanitizing requirements.
D. As Needed - Keep exterior surfaces (to include drip tray and cup rest) of dispenser cleaned with damp, clean cloth.

2.2 CLEANING AND SANITIZING SYSTEMS

A. General Information

1. Lancer equipment (new or reconditioned) is shipped from the factory cleaned and sanitized in accordance with NSF guidelines. The operator of the equipment must provide continuous maintenance as required by this manual and/or state and local health department guidelines to ensure proper operation and sanitation requirements are maintained.

NOTE: The cleaning and sanitizing procedures provided herein pertain to the Lancer equipment identified by this manual. If other equipment is being cleaned, follow the guidelines established for that equipment.

2. Cleaning and sanitizing should be accomplished only by trained personnel. Sanitary gloves are to be used during cleaning and sanitizing operations. Applicable safety precautions must be observed. Instruction warnings on the product being used must be followed.

IMPORTANT: Water lines are not to be disconnected during the cleaning and sanitizing of syrup lines to avoid contamination.

3. Recommended Preparation of Cleaning Solutions.

- a. Cleaning solutions (for example, Ivory Liquid, Calgon, etc.) mixed with clean, potable water at a temperature of 90 to 110 degrees Fahrenheit should be used to clean equipment. The mixture ratio, using Ivory Liquid, is one (1) ounce of cleanser to two (2) gallons of water. A minimum of four (4) gallons of cleaning mixture should be prepared.

NOTE: Extended lengths of product lines may require that an additional volume of solution be prepared.

- b. Any equivalent cleanser may be used as long as it provides a caustic based, non-perfumed, easily rinsed mixture containing at least two (2) percent sodium hydroxide (NaOH).

4. Recommended Preparation of Sanitizing Solutions.

- a. Sanitizing solutions should be prepared in accordance with the manufacturer's written recommendations and safety guidelines. For example, mix Diversol CX in clean, potable water at a temperature of 90 to 110 degrees Fahrenheit so that the solution provides 200 parts per million (PPM) available chlorine. A minimum of four (4) gallons of sanitizing solution should be prepared.

NOTE: Extended lengths of product lines may require that an additional volume of solution be prepared.

- b. Any equivalent sanitizing solution may be used as long as it is prepared in accordance with the manufacturer's written recommendations and safety guidelines, and provides 200 parts per million (PPM) available chlorine.

2.3 CLEANING AND SANITIZING FIGAL SYSTEMS

- A. Remove all ice from ice bin by melting with hot water.
- B. Remove quick disconnect from syrup tank.



CAUTION DO NOT USE A WIRE BRUSH TO CLEAN VALVES.

PRECAUCIÓN NO USE UN CEPILLO DE ALAMBRE PARA LIMPIAR LAS VÁLVULAS.

ATTENTION NE PAS UTILISER UNE BROSSE MÉTALLIQUE POUR NETTOYER VANNES.

- C. Using a clean plastic bristle brush and a detergent soap solution prepared in accordance with the instructions in Section 2.2, scrub both valves of the disconnect. Rinse with clean, potable water.
- D. Using a mechanical spray bottle and a sanitizing solution prepared in accordance with the instructions in Section 2.2, spray both halves of the quick disconnects. Allow to air dry.

NOTE: Please note that a fresh water rinse cannot follow sanitization of equipment. Purge only with the end use product. This is an NSF requirement.

- E. Connect syrup line to a syrup tank filled with clean, potable, room temperature water. Connect CO2 supply hose to tank and pressurize.
- F. Place waste container under applicable dispensing valve. Activate valve until water is dispensed. Flush and rinse line and fittings for a minimum of 60 seconds to remove all traces of residual product.

NOTE: Extended lengths of product lines may require additional time for flushing and rinsing lines.



WARNING TO AVOID POSSIBLE PERSONAL INJURY OR PROPERTY DAMAGE, DO NOT ATTEMPT TO REMOVE SYRUP TANK COVER UNTIL CO2 HAS BEEN RELEASED FROM TANK.

ADVERTENCIA PARA EVITAR POSIBLES LESIONES PERSONALES O DAÑOS MATERIALES, NO TRATE DE RETIRAR LA TAPA DEL TANQUE DE SOROPE HASTA QUE SE HAYA LIBERADO LA PRESIÓN DEL CO2 DEL TANQUE.

AVERTISSEMENT POUR ÉVITER DES BLESSURES OU DES DOMMAGES MATÉRIELS POSSIBLES, N'ESSAYEZ PAS DE RETIRER LE COUVERCLE DU RÉSERVOIR DE SIROP, JUSQU'À CE QUE DE LA PRESSION DE CO2 AIT ÉTÉ LIBÉRÉE DU RÉSERVOIR.

- G. Disconnect CO2 supply hose from the water filled syrup tank.
- H. Prepare cleaning solution as described in Section 2.2 above. Fill a tank with cleaning solution. Connect syrup line to the tank. Connect CO2 supply hose to tank and pressurize.
- I. Place waste container under applicable dispensing valve. Activate valve and draw cleaning solution through lines for a minimum of 60 seconds. This will ensure line is flushed and filled with cleaning solution. Allow line to stand for at least 30 minutes.

NOTE: Extended lengths of product lines may require additional time for flushing and filling lines.

- J. Disconnect CO2 supply hose from the tank.
- K. Connect syrup line to a tank filled with clean, potable, water at a temperature of 90 to 110°F. Connect CO2 supply hose to tank and pressurize.
- L. Place waste container under applicable dispensing valve. Activate valve to flush and rinse line and fittings for a minimum of 60 seconds to remove all traces of cleaning solution. Continue rinsing until testing with phenolphthalein shows that the rinse water is free of residual detergent.
- M. Disconnect CO2 supply hose from the tank.

- N. Fill a tank with sanitizing solution. Connect syrup line to the tank. Connect CO2 supply hose to tank and pressurize.
- O. Remove dispensing valve nozzle (twist and pull down) and pull out center mixing baffle. Using a plastic bristle brush and detergent soap solution scrub the nozzle, mixing baffle, bottom of dispensing valve, and cup lever. Rinse with clean water.
- P. Reassemble mixing baffle and nozzle.
- Q. Place waste container under applicable dispensing valve. Activate valve and draw sanitizing solution through line for a minimum of 60 seconds. This will ensure line is flushed and filled with sanitizing solution. Allow line to stand for at least 30 minutes.
- R. Disconnect CO2 supply hose from the tank.
- S. Reconnect syrup lines to syrup containers (for example, quick disconnects, figal containers, etc.) and ready unit for operation.

	<p>CAUTION FOLLOWING SANITIZATION, RINSE WITH END-USE PRODUCT UNTIL THERE IS NO AFTERTASTE. DO NOT USE A FRESH WATER RINSE. THIS IS A NSF REQUIREMENT. RESIDUAL SANITIZING SOLUTION LEFT IN THE SYSTEM CREATES A HEALTH HAZARD.</p>
	<p>PRECAUCIÓN DESPUÉS DE LA ESTERILIZACIÓN, ENJUAGUE CON EL PRODUCTO FINAL HASTA QUE ELIMINAR EL SABOR QUE QUEDA. NO ENJUAGUE CON AGUA FRESCA. ÉSTA ES UNA EXIGENCIA DE NSF. SI QUEDA SOLUCIÓN DE ESTERILIZACIÓN EN EL SISTEMA, GENERA UN PELIGRO PARA LA SALUD.</p>
	<p>ATTENTION DÉFENSE DE RINCER L'OUTIL À L'EAU FRAICHE IMMÉDIATEMENT APRÈS UN TRAITEMENT SEPTIQUE. EN CAS DE APRÈS-GOÛT, NE PURGER AVEC LE PRODUIT FINAL UNE EXIGENCE NSF.</p>

- T. Draw drinks and refill lines with end product to flush sanitizing solution from the dispenser.
- U. Test dispenser in normal manner for proper operation. Taste dispensed product to ensure there is no off-taste. If off-taste is found, additional flushing of syrup system may be required.
- V. Repeat cleaning, rinsing, and sanitizing procedures for each valve/syrup circuit.
- W. Clean exterior of unit as instructed in Section 2.6.
- X. Using a spray bottle of sanitizing solution, spray the underside of all dispenser valves, valve spouts and cup levers. Allow to air dry.
- Y. Fill ice bin with ice. Install ice bin cover on unit.

NOTE: Thoroughly rinse inside and outside of syrup tank that was used for sanitizing solution with plain water to remove all solution residue.

2.4 CLEANING AND SANITIZING BAG-IN-BOX (BIB) SYSTEMS

- A. Disconnect syrup quick disconnect coupling from syrup packages and connect coupling to a bag valve removed from an empty Bag-in-Box package.
- B. Place end of syrup inlet line, with bag valve attached, in a clean container filled with clean, potable, room temperature water.
- C. Place waste container under applicable dispensing valve. Activate valve until water is dispensed. Flush and rinse line and fittings for a minimum of 60 seconds to remove all traces of residual product.

NOTE: Extended lengths of product lines may require additional time for flushing and rinsing lines.

- D. Prepare cleaning solution as described in Section 2.2 above. Place end of syrup inlet line in container filled with cleaning solution.
- E. Place waste container under applicable dispensing valve. Activate valve and draw cleaning solution through lines for a minimum of 60 seconds. This will ensure line is flushed and filled with cleaning solution. Allow line to stand for at least 30 minutes.
- F. Place end of syrup inlet line in a clean container filled with clean, potable, water at a temperature of 90 to 110°F.
- G. Place waste container under applicable dispensing valve. Activate valve to flush and rinse line and fittings for a minimum of 60 seconds to remove all traces of cleaning solution. Continue rinsing until testing with phenolphthalein shows that the rinse water is free of residual detergent.
- H. Prepare sanitizing solution as described in Section 2.2 above. Place end of syrup inlet line in container filled with sanitizing solution which has been prepared.
- I. Activate valve and draw sanitizing solution through line for a minimum of 60 seconds. This will ensure line is flushed and filled with sanitizing solution. Allow line to stand for at least 30 minutes.
- J. Remove bag valve from quick disconnect coupling and reconnect syrup inlet line to syrup package. Ready unit for operation.



CAUTION FOLLOWING SANITIZATION, RINSE WITH END-USE PRODUCT UNTIL THERE IS NO AFTERTASTE. DO NOT USE A FRESH WATER RINSE. THIS IS A NSF REQUIREMENT. RESIDUAL SANITIZING SOLUTION LEFT IN THE SYSTEM CREATES A HEALTH HAZARD.

PRECAUCIÓN DESPUÉS DE LA ESTERILIZACIÓN, ENJUAGUE CON EL PRODUCTO FINAL HASTA QUE ELIMINAR EL SABOR QUE QUEDA. NO ENJUAGUE CON AGUA FRESCA. ÉSTA ES UNA EXIGENCIA DE NSF. SI QUEDA SOLUCIÓN DE ESTERILIZACIÓN EN EL SISTEMA, GENERA UN PELIGRO PARA LA SALUD.

ATTENTION DÉFENSE DE RINCER L'OUTIL À L'EAU FRAICHE IMMÉDIATEMENT APRÈS UN TRAITEMENT SEPTIQUE. EN CAS DE APRÈS-GOÛT, NE PURGER AVEC LE PRODUIT FINAL UNE EXIGENCE NSF.

- K. Draw drinks and refill lines with end product to flush sanitizing solution from the dispenser.
- L. Test dispenser in normal manner for proper operation. Taste dispensed product to ensure there is no off-taste. If off-taste is found, additional flushing of syrup system may be required.
- M. Repeat cleaning, rinsing, and sanitizing procedures for each valve circuit.

2.5 VALVES

- A. Valves may be cleaned and sanitized (see preparation in Section 2.2) in the same manner.
 - 1. Remove cover and disconnect power so the valve will not be activated during the cleaning procedure. Remove nozzle and diffuser. Wash these parts in cleaning solution; then immerse them in a bath of sanitizing solution for 15 minutes.
 - 2. Visually inspect around nozzle area for syrup residue. This area may be cleaned with warm water and cloth or with the nozzle brush supplied. Wipe off dispensing lever.
 - 3. Wearing sanitary gloves, remove, drain and air dry the nozzle and diffuser.
 - 4. Wearing sanitary gloves, replace diffuser, twist nozzle in place.
 - 5. Connect power and replace cover. Valve is ready for operation.

2.6 ICE BIN COMPARTMENT ON ALL ICE CHESTS

- A. The ice bin compartment of the dispenser should be thoroughly cleaned and sanitized at least once every month. Use the following procedure.
- B. Prepare cleaning solution and sanitizing solution in accordance with Section 2.2.
- C. Using the cleaning solution and a clean soft cloth, wash down the sides of the ice bin and the surface of the aluminum casting.
- D. Using clean, potable water, thoroughly rinse away the cleaning solution from the sides and surface of the casting.
- E. Using plastic sanitary gloves, soak a white cotton gauze cleaning rag in the sanitizing solution and wipe all surfaces in the ice compartment.

NOTE: Please note that a fresh water rinse cannot follow sanitization of equipment. Purge only with the end use product. This is an NSF requirement.

- F. Sanitizing of the ice compartment is complete. Refill with ice.

3. TROUBLESHOOTING

TROUBLE	CAUSE	REMEDY
3.1 No carbonation.	<p>A. Carbonator motor not running.</p> <p>B. Absence of CO2 gas.</p> <p>C. Gas only from valves.</p> <p>D. Carbonator tank air bound.</p> <p>E. CO2 gas pressure below 90 PSI (0.621 MPA)</p> <p>F. Carbonator motor running continuously.</p>	<p>A Check power supply. Be sure toggle switch is in ON position.</p> <p>B. Replace with full tank of CO2 gas.</p> <p>C. Check for power failure. Check fuses. Clean strainer on pump.</p> <p>D. Relieve gas pressure in tank by pulling ring on safety relief valve until water spurts out.</p> <p>E. Reset high pressure CO2 gas regulator to 90-110 PSI (0.621-0.758 MPA). Change CO2 tank if required.</p> <p>F. Check switch on carbonator. Check water in check valve for blockage. Check carbonator control. Check carbonator pump for efficiency.</p>
3.2 Noisy Carbonator Pump.	<p>A. Insufficient water supply or water leak, allowing air to be pulled into pump.</p> <p>B. Loose pump coupling.</p>	<p>A. Provide adequate water supply. Check strainer for cleanliness</p> <p>B. Tighten set screw on pump coupling.</p>
3.3 Off Taste in Soda.	<p>A. Leaking water check valve, allowing carbonated water to back into supply line.</p>	<p>A. Dismantle and clean check valve. Replace O-ring, if torn or distorted.</p>
3.4 Valves inoperable.	<p>A. Loss of Power.</p>	<p>A. Check power supply to see if plugged in. Check transformer circuit breaker. Check main power circuit breaker, 110V.</p>

4. DISPENSER DISPOSAL



To prevent possible harm to the environment from improper disposal, recycle the unit by locating an authorized recycler or contact the retailer where the product was purchased. Comply with local regulations regarding disposal of the refrigerant and insulation.

NOTES

5. ILLUSTRATIONS, PARTS LISTINGS, AND WIRING DIAGRAMS

5.1 LANCER ICE COOLED DISPENSER -- ACCESSORIES

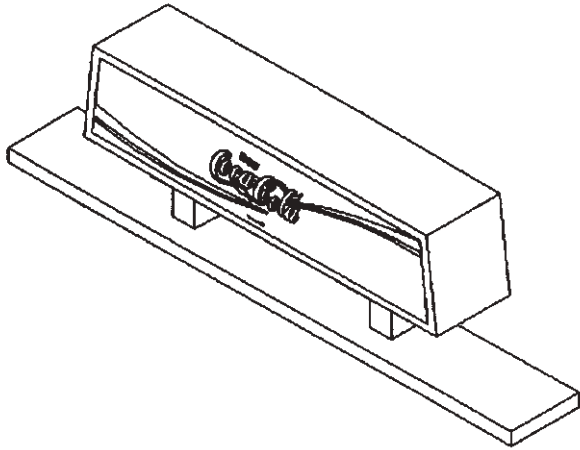

Illuminated Merchandiser
PN 85-2304

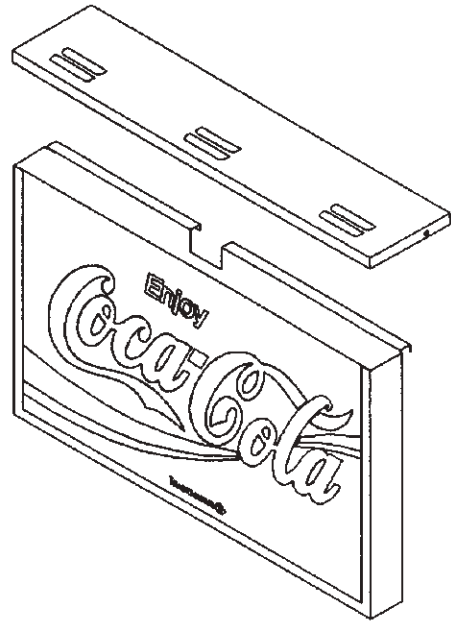

Illuminated Marquee
PN 85-2301

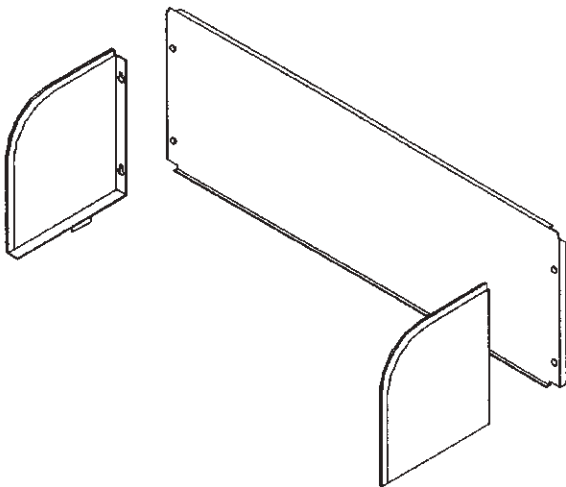

Splash Guards Kit
PN 82-2479

5.2 SERIES 1500 DROP-IN (PRE-MIX)

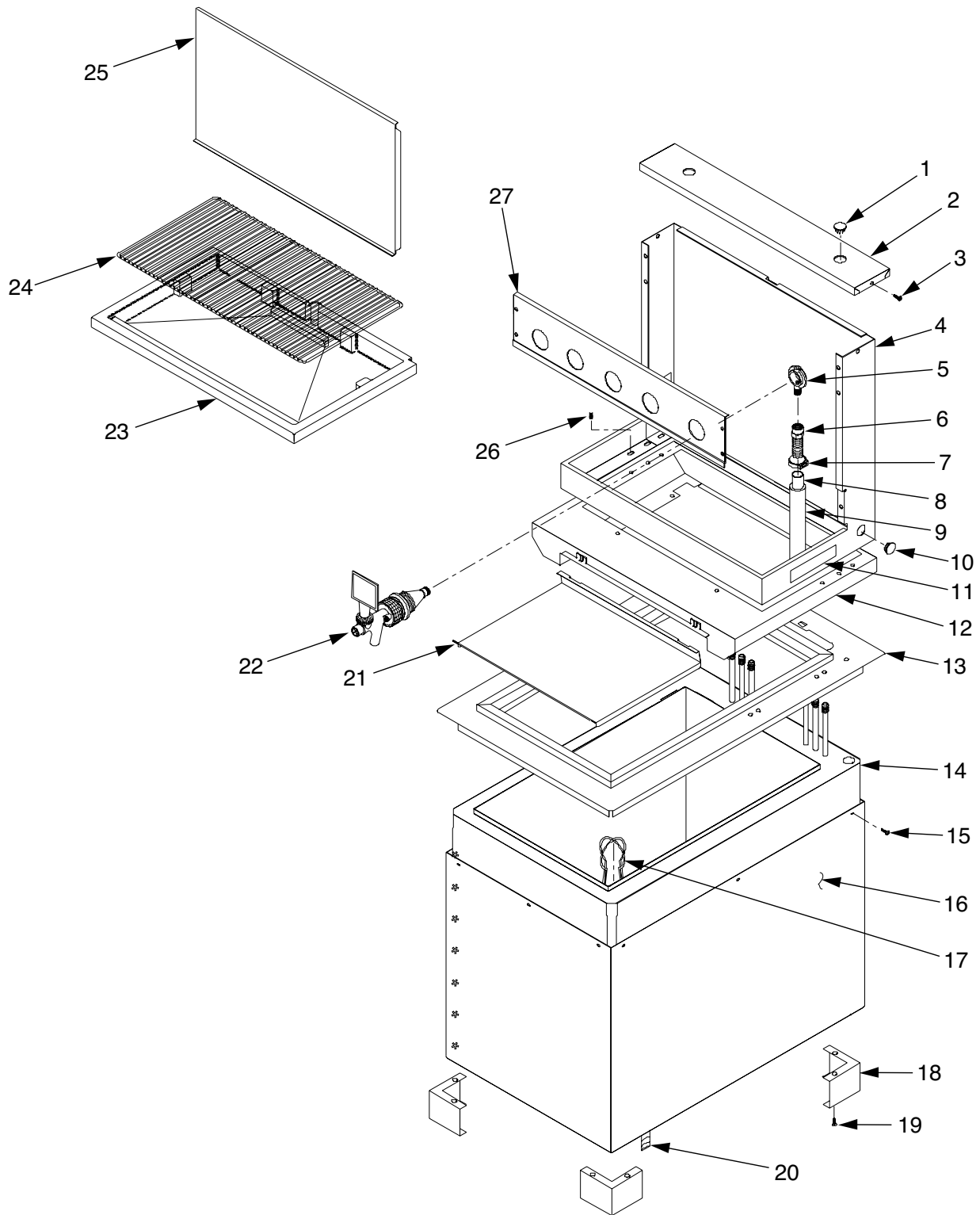

5.2 SERIES 1500 DROP-IN (PRE-MIX) (CONTINUED)

<u>Item</u>	<u>Part No.</u>	<u>Description</u>
1	07-0360	Plug
2	30-5985	Tower Cap, with Holes
3	04-0148	Screw, 10 - 32 X 0.250
4	51-5538	Tower Body
5	C-15-0794-100	Yoke Fitting
6	01-0222	Fitting
7	07-0438	Clamp, Oetiker
8	08-0263	Tubing, Red Line
9	88-0118	Insulation
10	07-0405	Plug
11	06-0645-204	Name Plate
-	06-0645-205	Name Plate
-	06-0645-206	Name Plate
R 12	51-5605	Base
13	51-5503	Rim
14	42-0038	Tank Assy, Foamed
15	04-0072	Rivet
R 16	30-7070/02	Wrapper
17	23-0862	Wire Drain
18	30-0294	Riser
19	04-0510	Screw, 8 - 18 X 0.500
20	01-1612	Drain Fitting
R 21	30-7332	Lid, Universal, 1523
22	19-0002	Valve, Pre Mix
23	05-1512	Drip Tray
24	23-1214	Cup Rest
25	30-7093-01	Splash Plate
26	04-1028	Screw, 10 - 32 X 0.375, HH, SS
27	30-6005	Faucet Plate (4 Valve)
-	30-6004	Faucet Plate (5 Valve)
-	30-6003	Faucet Plate (6 Valve)

NOTE: R in margin indicates revision

5.3 SERIES 1500 DROP-IN

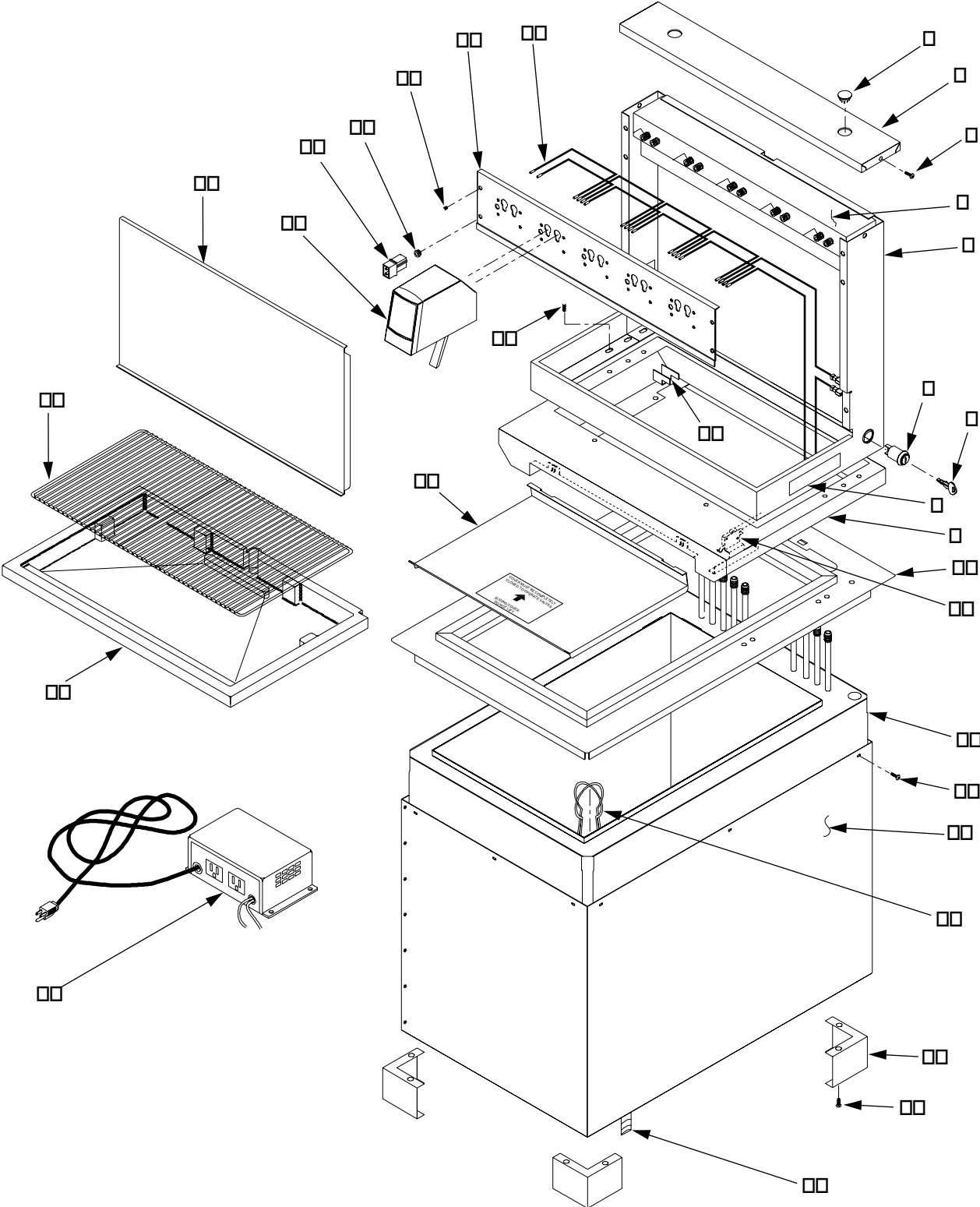

5.3 SERIES 1500 DROP-IN (CONTINUED)

<u>Item</u>	<u>Part No.</u>	<u>Description</u>
	1 07-0360	Plug
	2 30-5985	Tower Cap, with Holes
	3 04-0148	Screw, 10 - 32 X 0.250
	4 48-0810	Foamed Manifold (4 Valve, 3-1)
	- 48-1108	Foamed Manifold (5 Valve, 3-1 - 1)
	- 48-1054	Foamed Manifold (6 Valve, 3-2-1)
	- 48-0894	Foamed Manifold (5 Valve, 2-1-2)
	- 48-0895	Foamed Manifold (6 Valve, 3-1-2)
	5 51-5538	Tower Body
	6 12-0097	Key Lock
	7 81-0126	Keys
	8 06-0645-204	Name Plate (4 Valve)
	- 06-0645-205	Name Plate (5 Valve)
	- 06-0645-206	Name Plate (6 Valve)
R	9 51-5605	Base
	10 51-5503	Rim
	11 82-2112	Switch/Bracket Assy
	12 42-0040	Foamed Tank Assy
	13 04-0072	Rivet
R	14 30-7070/02	Wrapper
	15 23-0862	Wire Drain
	16 30-0294	Riser
	17 04-0510	Screw, 8 - 18 X 0.500
	18 01-1612	Drain Fitting
	19 82-1103	Power Supply
	20 05-1512	Drip Tray
	21 23-1214	Cup Rest
	22 30-7093	Splash Plate
R	23 30-7332	Lid, Universal, 1523
	24 19-0117	LEV®
	- 19-0118	LEV® with Soda Lever
	25 11-0015	Housing Socket
	26 13-0005	Bushing
	27 04-0558	Screw, 10 - 32 x 0.375
	28 30-5746/01	Faucet Plate (5 Valve, SS)
	- 30-5623/01	Faucet Plate (6 Valve, SS)
	29 52-0828/03	Wire Harness (5 Valve)
	- 52-0827/03	Wire Harness (6 Valve)
	30 04-1028	Screw, 10 - 32 X 0.375, HH, SS
	31 30-7259	Door stop

NOTE: R in margin indicates revision

5.4 SERIES 1500 PLUG-IN DROP-IN SABRE

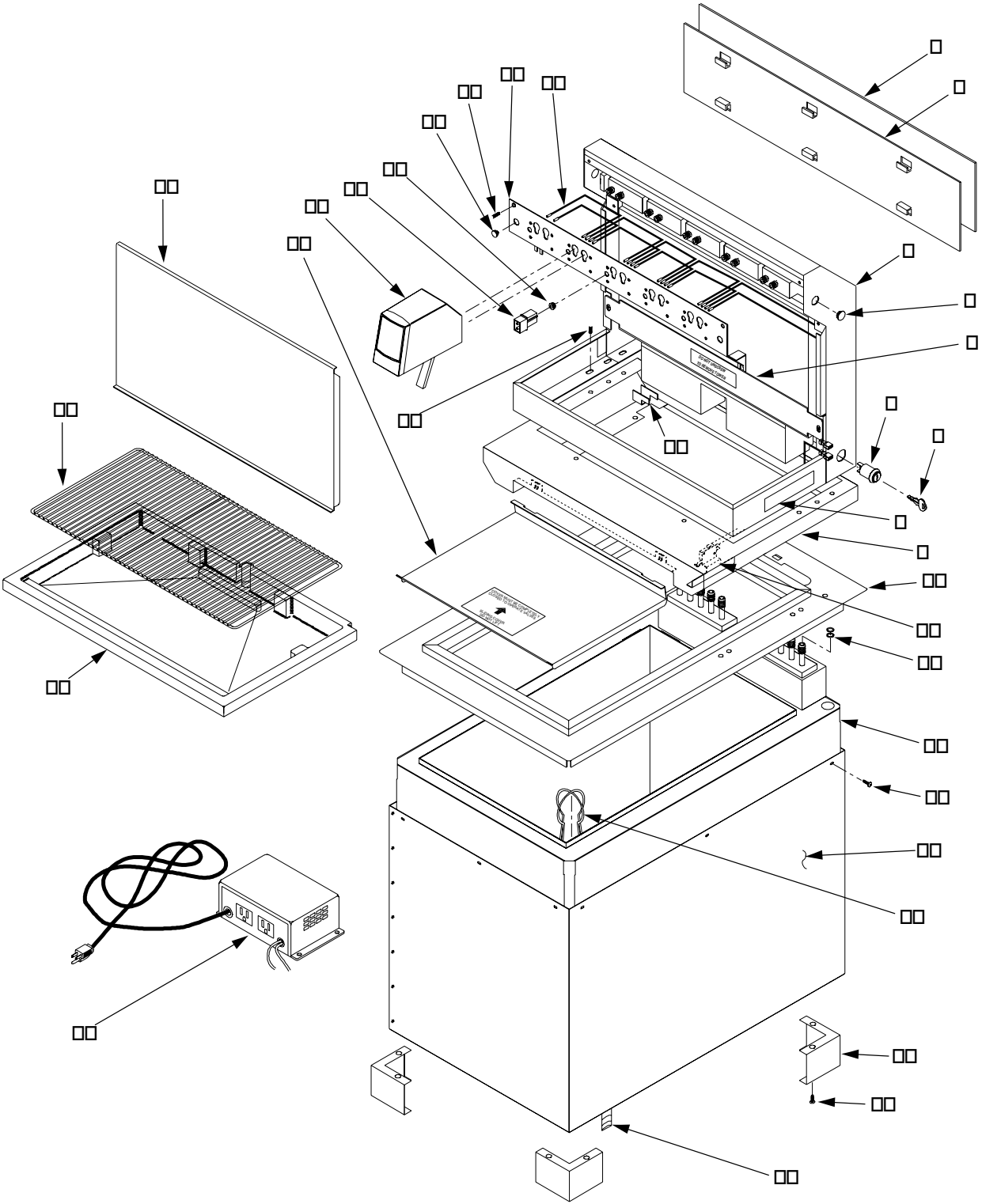

5.4 SERIES 1500 PLUG-IN DROP-IN SABRE (CONTINUED)

<u>Item</u>	<u>Part No.</u>	<u>Description</u>
	1 06-0234	Coca Cola Sabre Sign
	2 05-0332	Graphic Panel
	3 51-5505	Sabre Tower
	4 05-1516	Plug
	5 48-1148	Manifold Assy (5 Valve, Sabre)
	6 12-0097	Key Lock
	7 81-0126	Keys
	8 06-0645-255	Name Plate
R	9 51-5605	Base
	10 51-5503	Rim
	11 82-2112	Switch/Bracket Assy
	12 02-0003	O-Ring
	13 42-0051	Foamed Tank Assy
	14 04-0072	Rivet
R	15 30-7070/02	Wrapper
	16 23-0862	Wire Drain
	17 30-0294	Riser
	18 04-0510	Screw, 8 - 18 X 0.500
	19 01-1612	Drain Fitting
	20 82-1103	Power Supply
	21 05-1512	Drip Tray
	22 23-1214	Cup Rest
	23 30-7093	Splash Plate
R	24 30-7332	Lid, Universal, 1523
	25 19-0117	LEV®
	- 19-0118	LEV® with Soda Lever
	26 11-0015	Housing Socket
	27 13-0005	Bushing
	28 07-0556	Plug
	29 04-0558	Screw, 10 - 32 x 0.375
	30 51-5504	Faucet Plate (5 Valve Sabre)
	31 52-0828/03	Wire Harness (5 Valve)
	32 04-1028	Screw, 10 - 32 X 0.375, HH, SS
	33 30-7259	Door stop

NOTE: R in margin indicates revision

5.5 ICE COOLED UNIVERSAL WIRING DIAGRAM WITH BIN LID SWITCH

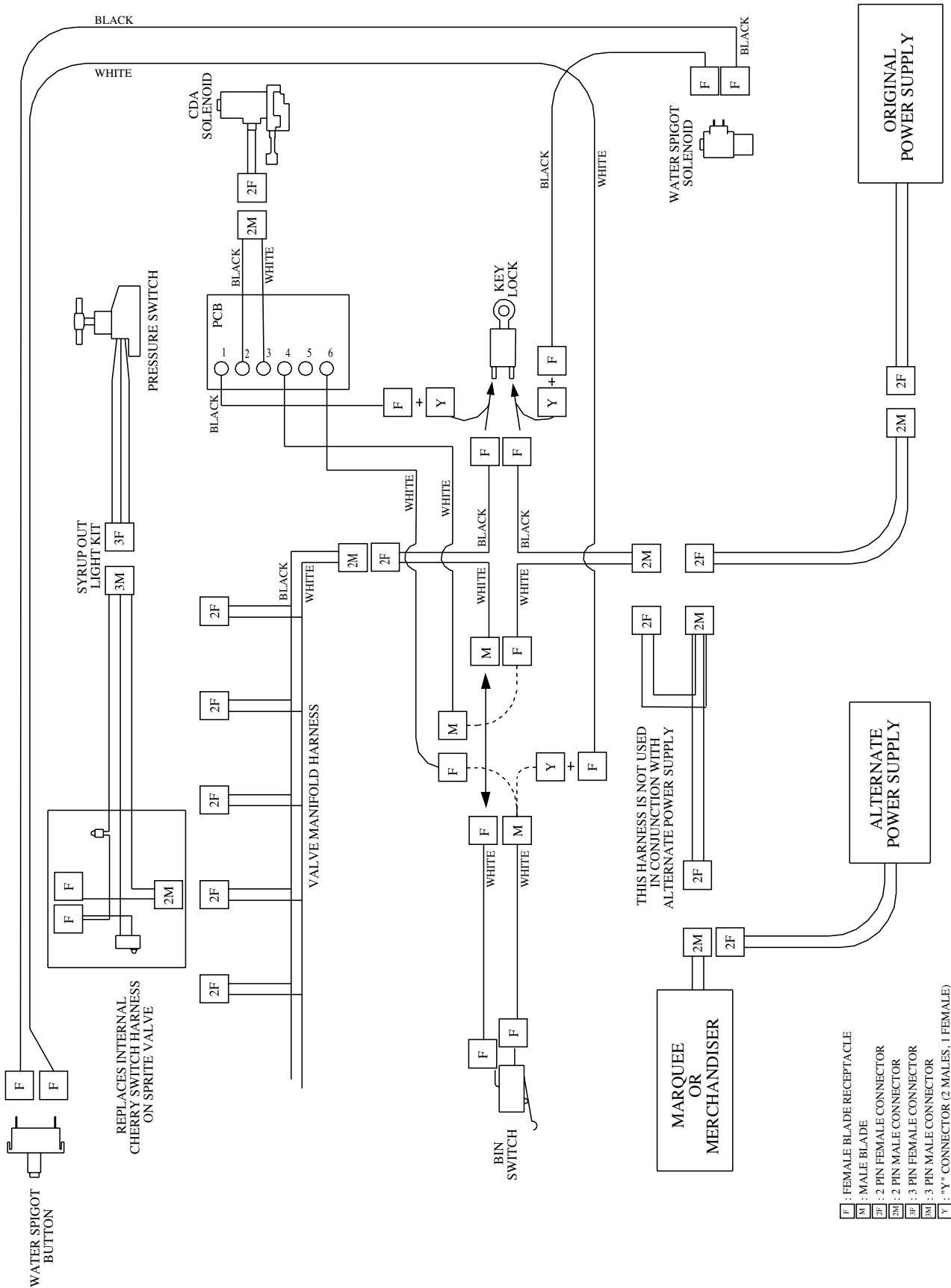

5.6 ICE COOLED UNIVERSAL WIRING DIAGRAM WITHOUT BIN LID SWITCH

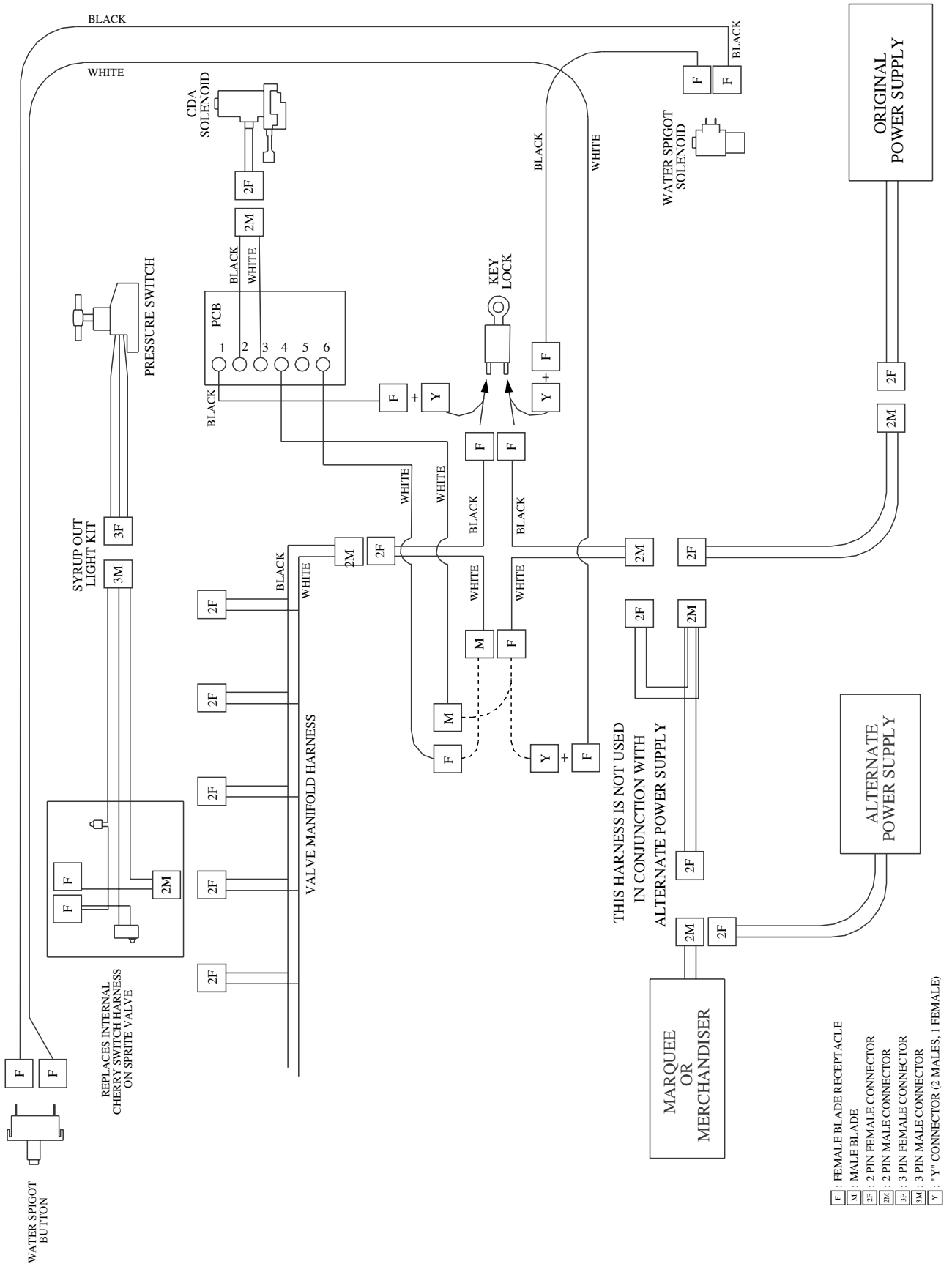

LANCER[®]

Lancer Corp.

800-729-1500

Technical Support/Warranty: 800-729-1550

custserv@lancercorp.com

lancercorp.com