



FOR QUALIFIED INSTALLER ONLY. This basic Installation Sheet is an initial release. If a complete Operations Manual (for the unit being installed) is required or needed, please refer to the Lancer web site (lancercorp.com) for immediate access, or for your convenience, scan this QR code with a mobile device (app required) for immediate access to other Technical Documents and alternative translations (if available) pertaining to this unit. Contact Lancer Customer Service for assistance as required.

ABOUT THIS MANUAL

This booklet is an integral and essential part of the product and should be handed over to the operator after the installation and preserved for any further consultation that may be necessary. Please read carefully the guidelines and warnings contained herein as they are intended to provide the user with essential information for the continued safe use and maintenance of the product. In addition, it provides **GUIDANCE ONLY** to the user on the correct services and site location of the unit.

BEFORE GETTING STARTED

Each unit is tested under operating conditions and is thoroughly inspected before shipment. At the time of shipment, the carrier accepts responsibility for the unit. Upon receiving the unit, carefully inspect the carton for visible damage. If damage exists, have the carrier note the damage on the freight bill and file a claim with carrier. Responsibility for damage to the dispenser lies with the carrier.

The installation and relocation, if necessary, of this product must be carried out by qualified personnel with up-to-date safety and hygiene knowledge and practical experience, in accordance with current regulations.

IMPORTANT SAFETY INSTRUCTIONS

⚠ Intended Use

The dispenser is for indoor use only. This unit is not a toy. Children should not be supervised not to play with appliance. It should not be used by children or infirm persons without supervision. This appliance is not intended for use by persons (including children) with reduced physical, sensory or mental capabilities, or lack of experience and knowledge, unless they have been given supervision or instruction concerning use of the appliance by a person responsible for their safety. Cleaning and user maintenance shall not be performed by children without supervision. The min/max ambient operating temperature for the dispenser is 40°F to 105°F (4°C to 41°C). Do not operate unit below minimum ambient operation conditions. Should freezing occur, cease operation of the unit and contact authorized service technician. Service, cleaning and sanitizing should be accomplished only by trained personnel. Applicable safety precautions must be observed. Instruction warnings on the product being used must be followed.

⚠ Automatic Agitation

Units are equipped with an automatic agitation system and will activate unexpectedly. Do not place hands or foreign objects in the ice bin. Unplug the dispenser during servicing, cleaning, and sanitizing. To avoid personal injury, do not attempt to lift the dispenser without assistance. For heavier dispensers, use a mechanical lift.



⚠ Electrical Warning

Check the dispenser name plate label, located behind the splash plate, for the correct electrical requirements of unit. Do not plug into a wall electrical outlet unless the current shown on the serial number plate agrees with local current available. Follow all local electrical codes when making connections. Each dispenser must have a separate electrical circuit. Do not use extension cords with this unit. Do not 'gang' together with other electrical devices on the same outlet. The keyswitch does not disable the line voltage to the transformer primary. Always disconnect electrical power to the unit to prevent personal injury before attempting any internal maintenance. The resettable breaker switch should not be used as a substitute for unplugging the dispenser from the power source to service the unit. Only qualified personnel should service internal components of electrical control housing. Make sure that all water lines are tight and units are dry before making any electrical connections!

⚠ Carbon Dioxide (CO₂)

- **WARNING:** Carbon Dioxide (CO₂) is a colorless, noncombustible gas with a light pungent odor. High percentages of CO₂ may displace oxygen in the blood.
- **WARNING:** Prolonged exposure to CO₂ can be harmful. Personnel exposed to high concentrations of CO₂ gas will experience tremors which are followed by a loss of consciousness and suffocation.
- **WARNING:** If a CO₂ gas leak is suspected, immediately ventilate the contaminated area before attempting to repair the leak.
- **WARNING:** Strict attention must be observed in the prevention of CO₂ gas leaks in the entire CO₂ and soft drink system.

⚠ Water Notice

Provide an adequate potable water supply. Water pipe connections and fixtures directly connected to a potable water supply must be sized, installed, and maintained according to federal, state, and local laws. The water supply line must be at least a 3/8 inches (9.525 mm) pipe with a minimum of 25 PSI (0.172 MPA) line pressure, but not exceeding a maximum of 50 PSI (0.345 MPA). Water pressure exceeding 50 PSI (0.345 MPA) must be reduced to 50 PSI (0.345 MPA) with the provided pressure regulator. Use a filter in the water line to avoid equipment damage and beverage off-taste. Check the water filter periodically, as required by local conditions. The water supply must be protected by means of an air gap, a backflow prevention device or another approved method to comply with NSF standards. A leaking inlet water check valve will allow carbonated water to flow back through the pump when it is shut off and contaminate the water supply. Ensure the backflow prevention device complies with ASSE and local standards. It is the responsibility of the installer to ensure compliance.

SPECIFICATIONS

DIMENSIONS

Width: 30.0 inches (762 mm)
Depth: 31.0 inches (787 mm)
Height: 37.25 inches (946 mm)

WEIGHT

Shipping: 335 lbs (152 kg)
Empty: 275 lbs (125 kg)
Ice Capacity: 250 lbs (113.6 kg)
Ice Dispensable: 185 lbs (84 kg)

ELECTRICAL

115 VAC / 60 Hz / 3.0 Amps

PLAIN WATER SUPPLY

Min Flowing Pressure: 75 PSIG (0.516 MPA)

CARBONATED WATER SUPPLY

Min Flowing Pressure: 25 PSI (0.172 MPA)
Max Static Pressure: 50 PSI (0.345 MPA)

CARBON DIOXIDE (CO₂) SUPPLY

Min Pressure: 70 PSIG (0.483 MPA)
Max Pressure: 80 PSIG (0.552 MPA)

FITTINGS

Carbonator Inlet: 3/8 inch barb
Plain Water Inlet: 3/8 inch barb
Brand Syrup Inlets: 3/8 inch barb

This unit emits a sound pressure level below 70 dB

READ THIS MANUAL

This manual was developed by the Lancer Corporation as a reference for the owner/operator and installer of this dispenser. Please read this guide before installation and operation of this dispenser. If service is required please call your Lancer Service Agent or Lancer Customer Service. Always have your model and serial number available when you call.

Your Service Agent: _____

Service Agent Telephone Number: _____

Serial Number: _____

Model Number: _____

INSTALLATION

Unpack the Dispenser

1. Set shipping carton upright on the floor then cut package banding straps and remove.
2. Open top of carton and remove interior packaging.
3. Lift carton up and off of the unit.
4. Remove plywood shipping base from unit by moving unit so that one side is off the counter top or table allowing access to screws on the bottom of the plywood shipping base.

NOTE

If unit is to be transported, it is advisable to leave the unit secured to the plywood shipping base.

5. Remove accessory kit and loose parts from ice compartment.

NOTE

Inspect unit for concealed damage. If evident, notify delivering carrier and file a claim against the same.

6. If leg kit has been provided, assemble legs by tilting unit.

Inspection of Drain Spider

NOTE

The drain spider is located to the right side near the front of the bin under the ice shroud. The coldplate has a cavity designed to hold the drain spider. During shipment, the drain spider may become dislodged from its original position. Prior to installing the unit, ensure the drain spider is in the correct position. This will prevent drain clog issues. Inspect the lower bin area and reach under the shroud to ensure the drain spider is secure in the coldplate cutout. If the spider is not in place, proceed with the following steps.

1. Remove agitator clip and pin from agitator bar.
2. Remove agitator bar from paddle wheel.
3. Remove paddle wheel.
4. Remove ice shroud by lifting back then out of bin.
5. Locate drain spider and reinstall in the coldplate cavity where drain line exits.
6. Reinstall all components. Ensure agitator clip is locked.

Selecting/Preparing Counter Location

NOTE

The dispenser should only be installed in a location where it can be overseen by trained personnel

1. Select a level, well ventilated location that is in close proximity to a properly grounded electrical outlet, within five (5) feet (1.5 m) of a drain, a water supply that meets the requirements shown in the Specifications section found on page 4, away from direct sunlight or overhead lighting, and has sufficient clearance for air circulation.

2. Sufficient clearance must be provided (if an ice maker is not installed) to allow filling ice compartment from a five (5) gallon bucket (a minimum of 16 inches is recommended).
3. Inspect the counter location where the unit is to be installed. Verify the selected counter is strong enough to safely support the weight of the dispenser, the ice, and the icemaker (if necessary) after counter cut out is made. The total weight (with icemaker) for this unit could exceed 800 pounds (383.6 kg).

NOTE

Lancer does **NOT** recommend the use of shaved or flake ice in the dispenser. The ice level should not exceed the height of the metal bin wall when filled manually.

4. Unit may be installed directly on countertop or on legs. If installed directly on the counter, unit must be sealed to the countertop with an FDA approved sealant. If an icemaker is to be mounted on top of dispenser, do not install dispenser on legs.

NOTE

NSF listed units must be sealed to the counter or have four (4) inch legs installed.

5. Select a location for the remote carbonator, syrup pumps, CO₂ tank, syrup containers, and water filter (recommended).

NOTE

Connecting lines can be run through the back of the dispenser or extend down through a counter cutout.

Leveling the Dispenser:

In order to facilitate proper dispenser drainage, ensure that the dispenser is level, front to back and side to side. Place a level on the top of the rear edge of the dispenser. The bubble must settle between the level lines. Repeat this procedure for the remaining three sides. Level unit if necessary. For optimum performance place the unit at a 0° tilt. The maximum tilt is 5°.

NOTE

To assure that beverage service is accessible to all customers, Lancer recommends that counter height and equipment selection be planned carefully. The 2010 ADA Standards for Accessible Design states that the maximum reach height from the floor should be no more than 48" if touch point is less than 10" from the front of the counter, or a maximum of 46" if the touch point is more than 10" and less than 27" from the front of the counter. For more information about the customer's legal requirements for the accessibility of installed equipment, refer to 2010 ADA Standards for Accessible Design - <http://www.ada.gov>.

Installing an Icemaker (if necessary)

⚠ ATTENTION

When installing an icemaker on the dispenser, use a bin thermostat to control the ice level (see below). This will prevent damage to the dispensing mechanism. The bracket for mounting a thermostat is located in the ice bin. During the automatic agitation cycle and while dispensing ice, ensure there is adequate space between the top of the ice level and the bottom of the icemaker so the ice can move without obstruction. Contact your icemaker manufacturer for information on a suitable bin thermostat.

1. Install the icemaker per manufacturer specifications. Points of consideration include drainage, ventilation, and drop zones.
2. An adapter plate is required when installing an icemaker. Contact your Sales Representative or Lancer Customer Service for more information.
3. A bin thermostat is required in order to control the level of ice in the dispenser (Refer to ATTENTION above). Contact your icemaker manufacturer to obtain the correct bin thermostat.
4. Bin thermostat should be a minimum of 2" below the top edge of the dispenser. The preferred location of the bin thermostat is on the left side wall.

Attach Bin Stat Bracket As Shown

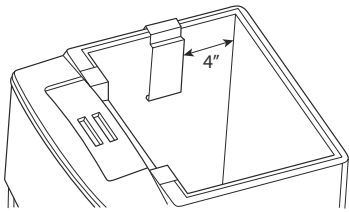

Recommended Bin Stat Attachment

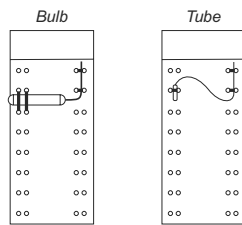

⚠ ATTENTION

Failure to use an ice bin thermostat will not only void your IBD's warranty but will result in the inability to control the level of ice in the ice bin which can cause damage to your dispenser.

5. Ensure the icemaker is installed properly to allow for removal of the Merchandiser.
6. Ensure manual fill is accessible.
7. Clean and maintain icemaker per manufacturer's instructions.

Dispenser Installation

NOTE

The installation, and relocation if necessary, must be carried out by qualified personnel with up-to-date knowledge and practical experience, in accordance with current regulations.

1. Install unit to counter.
2. Remove the splash plate and top cover.

3. Remove the merchandiser by removing the two (2) screws located on the faucet plate (from left to right) above the third (3rd) and sixth (6th) valve.
4. Remove the drip tray and cup rest.
5. Route appropriate tubing from the water source to the plain water inlet at the front of the unit and connect tubing to inlet using the oetiker pliers and fittings, (see Plumbing Diagram on the front of the unit or on page XX for reference).

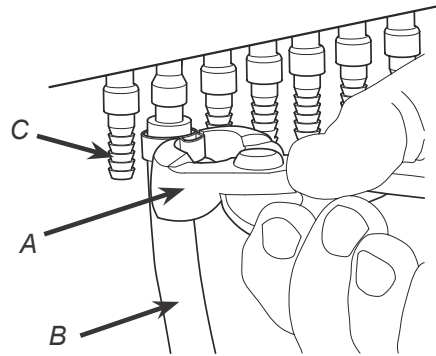

A. Oetiker Pliers
B. Tubing
C. Syrup/Water Inlet

6. Route appropriate tubing from the remote carbonator to the carbonated water inlet and connect tubing to inlet.
7. If no remote carbonator is installed, install the carbonator per manufacturer's instructions.
8. Connect tubing to water source then flush water lines to check for leaks.
9. Route appropriate tubing from the syrup pump location to the syrup inlets in front of the unit and connect tubing to all inlets.
10. Route appropriate tubing from the CO₂ source location to the CO₂ inlet at the remote carbonator location.
11. Route the power supply cord to a grounded electrical outlet of the proper voltage and amperage rating.

⚠ WARNING

DO NOT PLUG UNIT INTO GROUNDED ELECTRICAL OUTLET AT THIS TIME. Make sure that all water lines are tight and unit is dry before making any electrical connections

12. Route drain hose from designated open type drain to fitting on Drip Tray and connect hose to fitting.

⚠ CAUTION

Drain line must be insulated with a closed cell insulation. Insulation must cover the entire length of the drain hose, including fittings. The drain should be installed in such a manner that water does not collect in sags or other low points, as condensation will form.

⚠ ATTENTION

Pouring hot water down the drain may cause the Drain Tube to collapse. Allow only luke warm or cold water to enter the Drain Tube. Pouring coffee, tea, or other similar substances down the drain may cause the Drain Tube to become clogged.

13. Reattach Drip Tray/Cup Rest to unit.

Installing CO₂ Supply

1. Connect high pressure CO₂ regulator assembly to CO₂ cylinder or bulk system.

⚠ ATTENTION

Before installing regulator, assure that a seal (washer or o-ring) is present in regulator attachment nut.

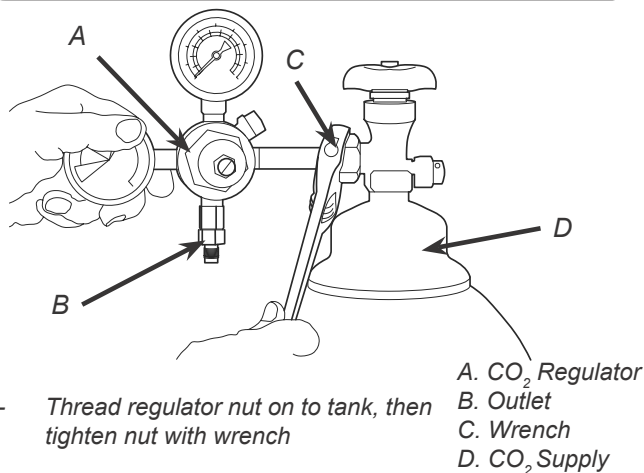

- Thread regulator nut on to tank, then tighten nut with wrench

2. Connect a 1/4" nut, stem and seal to CO₂ regulator outlet.
3. Route tubing from the syrup pump location to the 1/4" nut, stem on the high pressure CO₂ regulator attached to source and connect tubing.

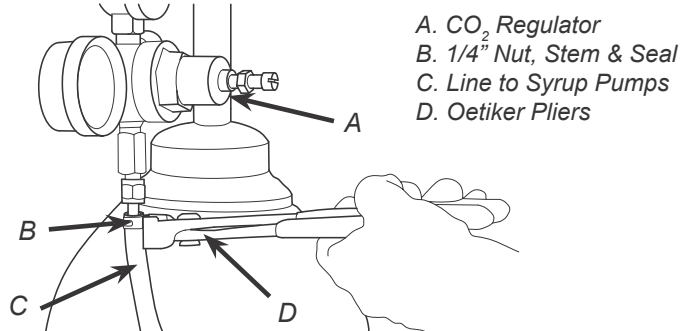

4. Using a wrench, loosen lock nut on the regulator adjustment screw of the high pressure CO₂ regulator connected to the source, then using a screwdriver back out lock nut screw all the way.

⚠ WARNING

DO NOT TURN ON CO₂ SUPPLY AT THIS TIME

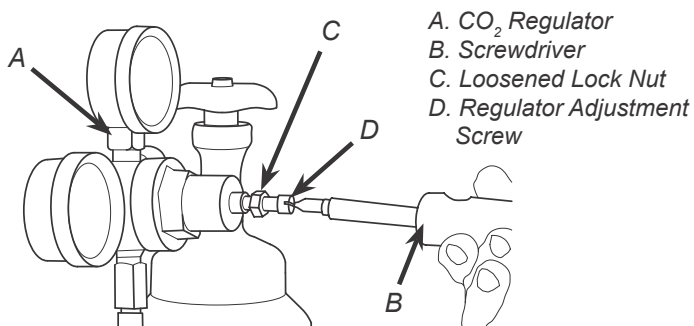

Dispenser Setup

1. Turn on water source.
2. Open the pressure relief valve, located on the remote carbonator, by flipping up on the valve cap lever. Hold open until water flows from the relief valve then close (flip down) the relief valve.
3. Verify all Bag-In-Box contains syrup and check all connections for leaks.
4. Place enough ice in the ice bin to fill approximately 1/2 of the bin before plugging in the unit.
5. Connect unit power cord to grounded electrical outlet.

⚠ WARNING

The dispenser must be properly electrically grounded to avoid serious injury or fatal electrical shock. The power cord has a three-prong grounded plug. If a three-hole grounded electrical outlet is not available, use an approved method to ground the unit. Follow all local electrical codes when making connections. Each dispenser must have a separate electrical circuit. Do not use extension cords. Do not connect multiple electrical devices on the same outlet.

6. Test the motor operation by pushing both ice chute levers until agitator motor begins to turn.
7. Activate each valve to ensure a good flow of water is achieved.
8. Ensure pump deck is turned OFF before turning on CO₂.

⚠ ATTENTION

Failure to disconnect the motor power supply will damage the carbonator motor, the pump and void the warranty.

9. Turn on CO₂ at the source then, using a screwdriver, adjust the high pressure regulator at the source to 75 PSI (0.517 MPA) then tighten locknut with wrench.

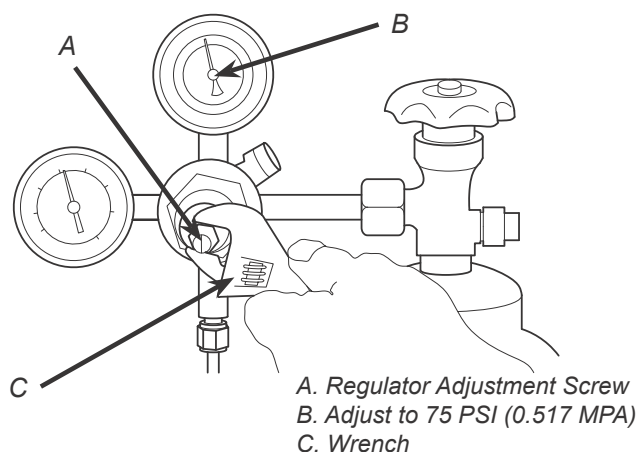

10. Activate each valve until gas-out.
11. Plug in the remote carbonator pump deck, if not already done so, and turn the switch to the ON position.

12. Activate each valve until the carbonator pump comes on. Release the button, allow carbonator to fill and stop. Repeat this process until a steady flow of carbonated water is achieved.

NOTE

The pump deck has a 3 minute timeout feature. If the timeout occurs, turn the deck OFF then ON by flipping the switch on the control box.

NOTE

To check for CO₂ leaks, close the valve on the CO₂ cylinder and observe if the pressure to the system drops with the cylinder valve closed for five minutes. Open the cylinder valve after check.

13. Activate each valve to purge air from the syrup lines.

Adjust Water Flow Rate & Syrup/Water Ratio

NOTE

Ensure there is ice on the cold plate and the lines are cold before attempting to set the flow rates on the valves. The drink temperature should be no higher than 40°F (4.4°C) when flow rates are set.

1. Remove valve cover from first valve.
2. Close syrup shut-off at mounting block for first valve.

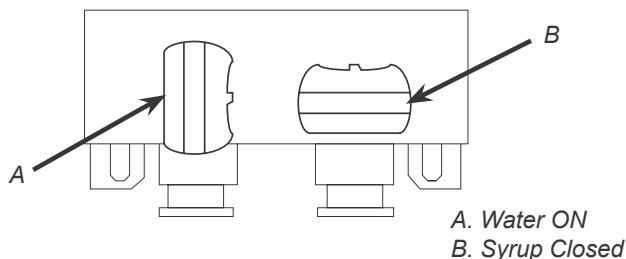

3. Using a Lancer ratio cup verify water flow rate (5 oz. in 4 sec.). Use a screwdriver to adjust if needed.

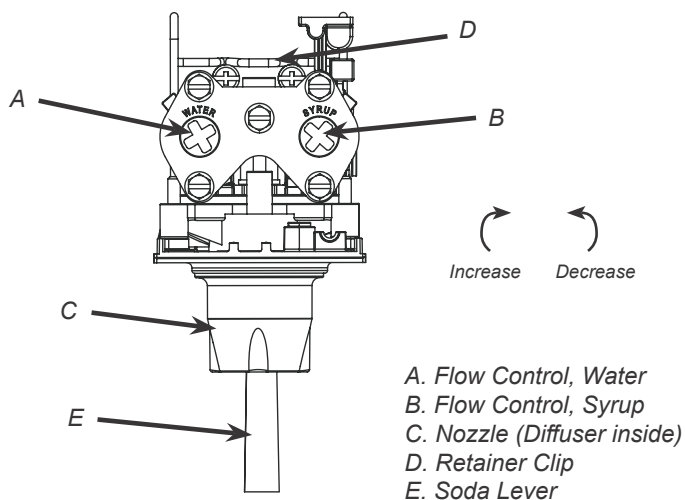

4. Remove nozzle by twisting counter clockwise and pulling down, then remove diffuser by pulling down.

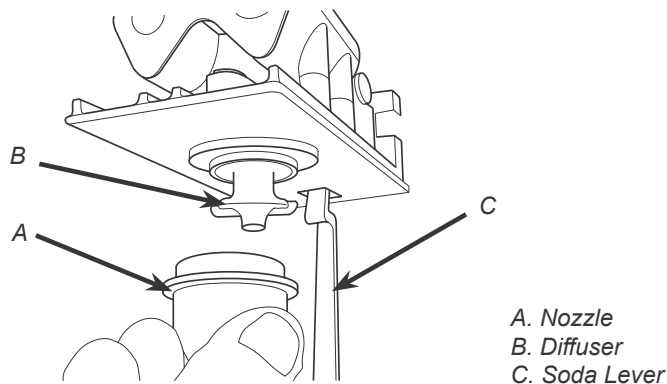

5. Install Lancer (yellow) syrup separator (PN 54-0031) in place of nozzle.

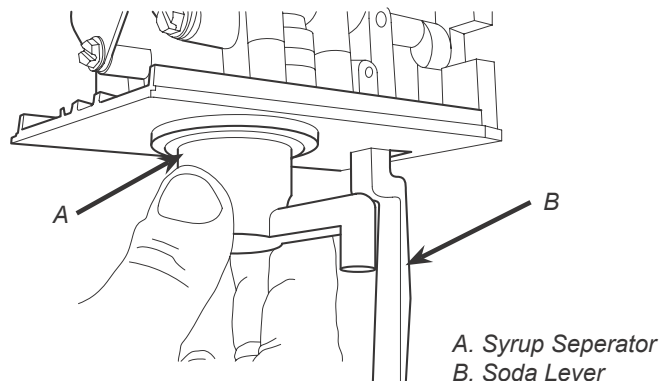

6. Re-open syrup shut-off at mounting block.
7. Activate valve to purge syrup until steady flow is achieved.
8. Using a Lancer brix cup, activate the valve and capture a sample. Verify that the syrup level is even with the water level. Use a screwdriver to adjust if needed.

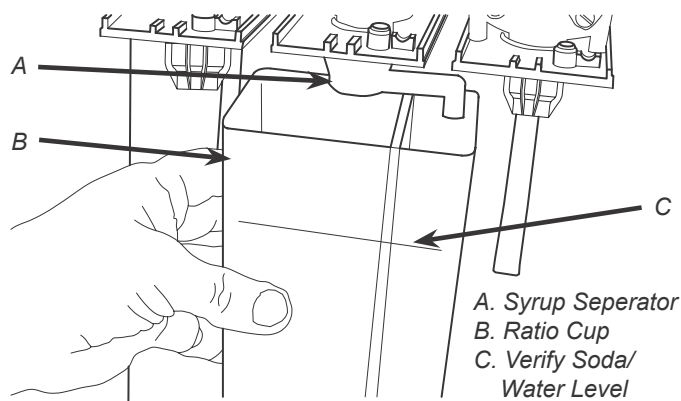

9. Remove syrup separator and reinstall nozzle. Replace valve cover.
10. Repeat steps 1-8 for each valve.
11. Re-install merchandiser, splash plate, and top cover.

CLEANING AND SANITIZING

GENERAL INFORMATION

Lancer equipment (new or reconditioned) is shipped from the factory cleaned and sanitized in accordance with NSF guidelines. The operator of the equipment must provide continuous maintenance as required by this manual and/or state and local health department guidelines to ensure proper operation and sanitation requirements are maintained.

The cleaning procedures provided herein pertain to the Lancer equipment identified by this manual. If other equipment is being cleaned, follow the guidelines established by the manufacturer for that equipment.

Cleaning should be accomplished only by trained personnel. Sanitary gloves are to be used during cleaning operations. Applicable safety precautions must be observed. Instruction warnings on the product being used must be followed.

⚠ ATTENTION

- Use sanitary gloves when cleaning the unit and observe all applicable safety precautions.
- **DO NOT** use a water jet to clean or sanitize the unit.
- **DO NOT** disconnect water lines when cleaning and sanitizing syrup lines, to avoid contamination.
- **DO NOT** use strong bleaches or detergents; These can discolor and corrode various materials.
- **DO NOT** use metal scrapers, sharp objects, steel wool, scouring pads, abrasives, or solvents on the dispenser.
- **DO NOT** use hot water above 140° F (60° C). This can damage the dispenser.
- **DO NOT** spill sanitizing solution on any circuit boards. Insure all sanitizing solution is removed from the system.

Cleaning Solution

Mix a mild, non-abrasive detergent (e.g. Sodium Laureth Sulfate, dish soap) with clean, potable water at a temperature of 90°F to 110°F (32°C to 43°C). The mixture ratio is one ounce of cleaner to two gallons of water. Prepare a minimum of five gallons of cleaning solution. Do not use abrasive cleaners or solvents because they can cause permanent damage to the unit. Ensure rinsing is thorough, using clean, potable water at a temperature of 90°F to 110°F. Extended lengths of product lines may require additional cleaning solution.

Sanitizing Solution

Prepare the sanitizing solution in accordance with the manufacturer's written recommendations and safety guidelines. The type and concentration of sanitizing agent recommended in the instructions by the manufacturer shall comply with 40 CFR §180.940. The solution must provide 200 parts per million (PPM) chlorine (e.g. Sodium Hypochlorite or bleach) and a minimum of five gallons of sanitizing solution should be prepared.

Other Supplies Needed

1. Clean cloth towels
2. Bucket
3. Extra nozzle
4. Sanitary gloves
5. Small brush (PN 22-0017)

Scheduled Maintenance/Cleaning

As Needed	<ul style="list-style-type: none"> • Keep exterior surfaces of unit clean using a clean, damp cloth.
Daily	<ul style="list-style-type: none"> • Using the cleaning solution, clean top cover and all exterior stainless steel surfaces. • Clean exterior of dispensing valves and ice chute. • Remove cup rest then clean the drip tray and cup rest. Replace cup rest and drip tray when finished. • Wipe clean all splash areas using a damp cloth soaked in cleaning solution. • Clean beverage nozzles as specified by their corresponding cleaning and sanitizing sections found on the next page of this manual.
Monthly	<ul style="list-style-type: none"> • Clean the ice bin, auger, and ice chute assembly as specified by the section "Cleaning and Sanitizing Ice Bin, Auger, and Ice Chute" on page XX.
Every Six Months	<ul style="list-style-type: none"> • Clean the syrup lines as specified by the section "Cleaning and Sanitizing Syrup Lines - Bag in Box" on page XX. • Pull out unit (if applicable) and clean behind and underneath. Check for any loose components or noises.

Cleaning and Sanitizing Nozzles

1. Disconnect power, so as to not activate valve while cleaning.
2. Remove merchandiser to reveal valves.
3. Remove nozzle by twisting counter clockwise and pulling down.
4. Remove diffuser by pulling down.

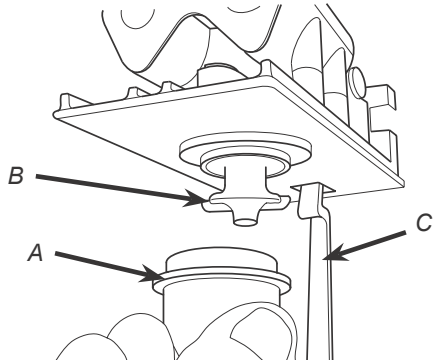

A. Nozzle
B. Diffuser
C. Soda Lever

5. Rinse nozzle and diffuser with warm water.
6. Wash nozzle and diffuser with cleaning solution then immerse in sanitizing solution and let sit for fifteen (15) minutes.
7. Set nozzle and diffuser aside and let air dry. **DO NOT** rinse with water after sanitizing.
8. Reconnect diffuser and nozzle.
9. Connect power.
10. Taste the drink to verify that there is no off-taste. If off-taste is found, flush syrup system again.

⚠ CAUTION

Following sanitization, rinse with end-use product until there is no aftertaste. Do not use a fresh water rinse. This is a NSF requirement. Residual sanitizing solution left in the system creates a health hazard.

Cleaning and Sanitizing Ice Bin, Auger, and Ice Chute

NOTE

It is recommended to perform this procedure monthly, or more often if desired. Use the cleaning solution described on page 7. An alternate solution of one part water to one part vinegar may be used to remove water spots and calcium deposits.

NOTE

Refer to the Automatic Agitation Warning on the first page of this manual.

1. Disconnect power to the dispenser
2. Remove the Merchandiser and Top Cover.
3. Remove Ice Chute Lever, then remove Splash Plate Assembly by lifting it up and out from the dispenser face.

NOTE

Always remove the ice chute lever before removing the splash plate.

4. Remove or melt out any remaining ice from the ice bin.
5. Use a screwdriver to remove the Auger Motor shaft cover.
6. Remove the "C" clip from the Auger Motor Shaft.

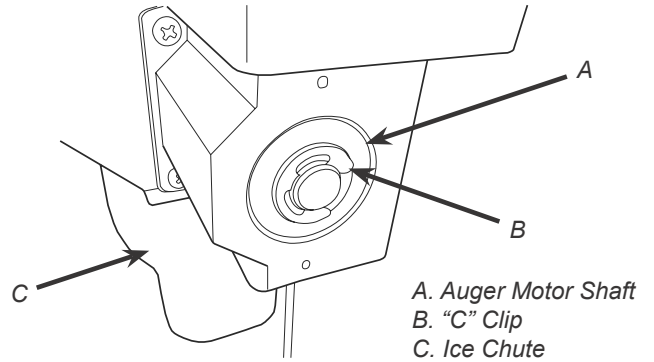

A. Auger Motor Shaft
B. "C" Clip
C. Ice Chute

7. Disconnect the Auger Motor wire harness from junction box.
8. Remove the four (4) screws from the bracket holding the Auger Motor, flavor injector bracket, and LED light bracket.
9. Slide the Motor and Mounting Plate Assembly off of the Auger Shaft.

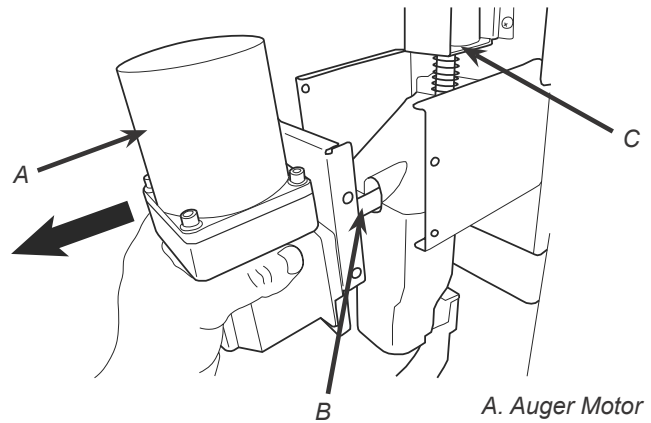

A. Auger Motor
B. Auger Shaft
C. Solenoid

10. Remove the Auger Motor Shaft Key and set aside.
11. Remove the second clip from the Auger Shaft.
12. Disconnect the Ice Chute wire harness from the junction box.
13. Disconnect the solenoid from Ice Chute link by pushing pin through shaft until link is free. (Pin shown in out position)

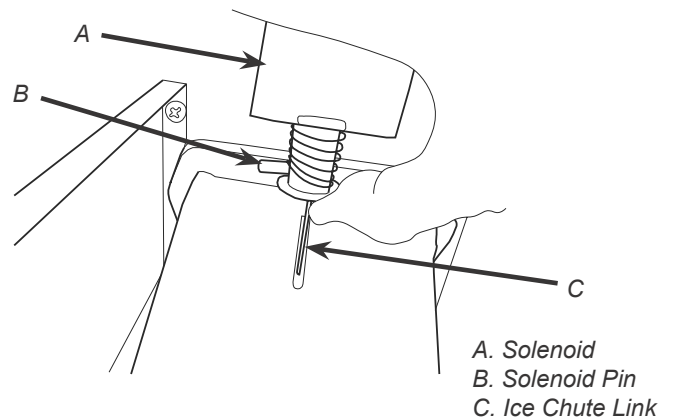

A. Solenoid
B. Solenoid Pin
C. Ice Chute Link

- Remove the Ice Chute Assembly by removing four (4) screws that secure to unit and set aside.
- Remove Auger by pulling straight out from unit and set aside.
- Remove Agitator Clip and Pin from Agitator bar in Ice Bin.

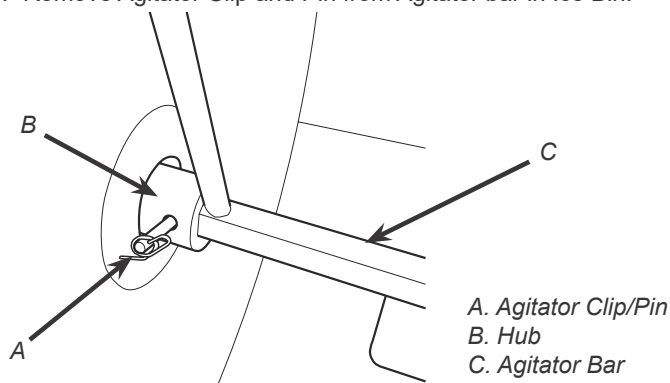

- Remove the Agitator bar and Hub from the Ice Bin.
- Remove the plastic Ice Shroud from Ice Bin and set aside.
- Using the Cleaning Solution (page 7) and a clean cloth or soft brush, clean the Ice Chute Assembly, Ice Shroud, Auger, all sides of the Ice Bin, and surface of the aluminum casting.
- Using the Cleaning Solution and the sponge brush provided, clean all interior surfaces of the ice chute and the ice chute feed through.
- Repeat Step 20 for all exterior surfaces of the dispenser.
- Using hot water, thoroughly rinse away the cleaning solution.
- Wearing sanitary gloves, use a clean cloth or towel and the Sanitizing Solution (page 12) to wash all surfaces of removable parts, sides of the Ice Bin, and surface of the aluminum casting.
- Using the Sanitizing Solution and the sponge brush provided, clean all interior surfaces of the ice chute and the ice chute feed through.

- Repeat Step 24 for all exterior surfaces of the dispenser.
- Wearing sanitary gloves, reassemble all removable parts. Ensure agitator clip is locked.
- Fill unit with ice and replace Top Cover.
- Reconnect Dispenser to power source.

Cleaning and Sanitizing Syrup Lines - Bag in Box

- Disconnect syrup lines from BIB's
- Place syrup lines, with BIB connectors, in a bucket of warm water.
- Activate each valve to fill the lines with warm water and flush out syrup remaining in the lines.
- Prepare Cleaning Solution described on previous page.
- Place syrup lines, with BIB connectors, into cleaning solution.
- Activate each valve until lines are filled with cleaning solution then let stand for ten (10) minutes.
- Flush out cleaning solution from the syrup lines using clean, warm water.
- Prepare Sanitizing Solution described on previous page.
- Place syrup lines into sanitizing solution and activate each valve to fill with sanitizer. Let sit for ten (10) minutes.
- Reconnect syrup lines to BIB's and draw drinks to flush solution from the dispenser.
- Taste the drink to verify that there is no off-taste. If off-taste is found, flush syrup system again.

⚠ CAUTION

Following sanitization, rinse with end-use product until there is no aftertaste. Do not use a fresh water rinse. This is a NSF requirement. Residual sanitizing solution left in the system creates a health hazard.

PLUMBING DIAGRAM

LANCER

RECOMMENDED PLUMBING

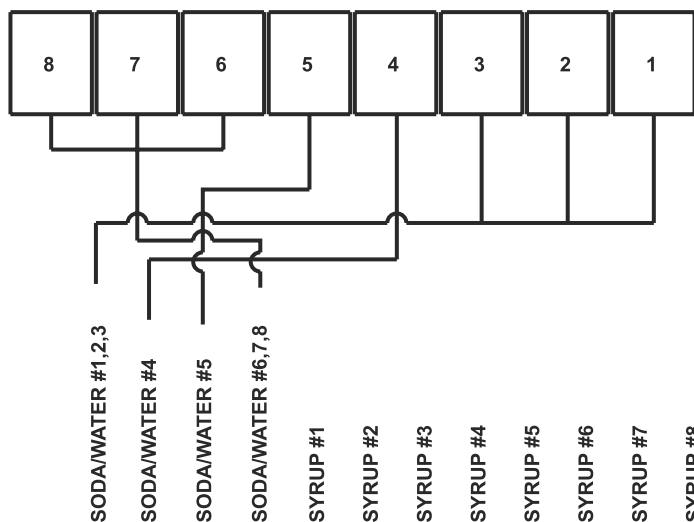

SYRUP LINES NOT SHOWN
3-1-1-3 CONFIGURATION
FOR ASSISTANCE CALL 1-800-729-1500
PART NO: 06-2226

WIRING DIAGRAMS

Sensation 30 115 Volt Wiring Diagram

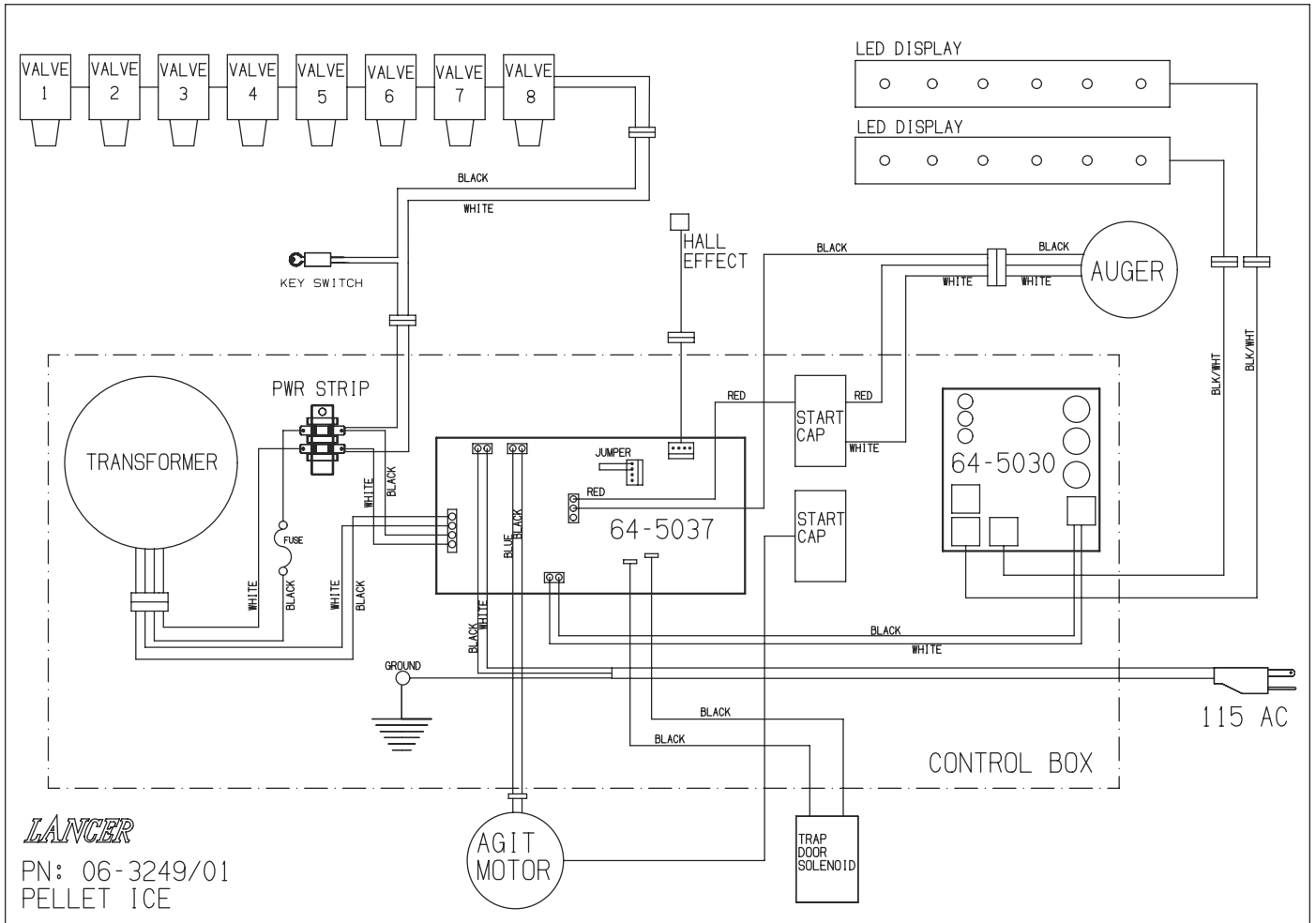

Agitation Controls

DIP SWITCH LEGEND

SW1

SWITCH #		AUTO AGITATE OFF TIME
3	4	
OFF	OFF	NO AUTO AGITATION
OFF	ON	20 MINUTES
ON	OFF	40 MINUTES
ON	ON	60 MINUTES

SWITCH #		REFILL START AFTER
7	8	
OFF	OFF	6 SEC DISPENSED
OFF	ON	9 SEC DISPENSED
ON	OFF	12 SEC DISPENSED
ON	ON	15 SEC DISPENSED

SWITCH #		REFILL ON TIME
5	6	
OFF	OFF	11 SECONDS
OFF	ON	9 SECONDS
ON	OFF	7 SECONDS
ON	ON	5 SECONDS

SW2 SWITCH 1: MUST BE ON FOR
CORRECT OPERATION

SW1 SWITCH 1: "LOW ICE" LED
INDICATOR ENABLED

SW1 SWITCH 2: "LOW ICE"
ALARM ENABLED

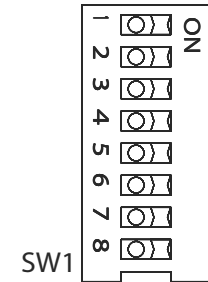
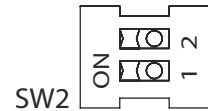

LANCER PN: 06-3289

Dispenser Disposal

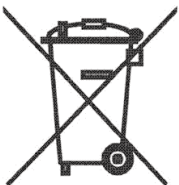

To prevent possible harm to the environment from improper disposal, recycle the unit by locating an authorized recycler or contact the retailer where the product was purchased. Comply with local regulations regarding disposal of the refrigerant and insulation.

LANCER[®]

Lancer Corp.
800-729-1500
Technical Support/Warranty: 800-729-1550
custserv@lancercorp.com
lancercorp.com