

LANCER®

Ice Cooled Drop-In Series 2300

Standard Performance



Operation Manual

Lancer Corporation
6655 Lancer Blvd.
San Antonio, Texas 78219
800-729-1500



Tech Support/Warranty: 800-729-1550

email: custserv@lancercorp.com

web: lancercorp.com

Lancer PN: 28-3026

Revision: February 2019

"Lancer" is the registered trademark of Lancer © 2019 by Lancer, all rights reserved.

TABLE OF CONTENTS

ABOUT THIS MANUAL

This booklet is an integral and essential part of the product. Please carefully read the guidelines and warnings contained herein as they are intended to provide the user with essential information for the continued safe use and maintenance of the product. In addition, it provides **GUIDANCE ONLY** to the user on the correct services and site location of the unit.

The installation and relocation, if necessary, of this product must be carried out by qualified personnel with up-to-date safety and hygiene knowledge and practical experience, in accordance with current regulations.

IMPORTANT SAFETY INSTRUCTIONS.....	3
Intended Use.....	3
Power Warning.....	3
CO ₂ Warning.....	3
Water Notice.....	3
SPECIFICATIONS AND FEATURES.....	4-8
ICD 2300 Standard Performance.....	4
General Systems Overview - Remote Syrup Pumps.....	5
Pre-Installation Checklist.....	5
INSTALLATION.....	6-11
Unpacking the Dispenser.....	6
Selecting/Preparing a Counter Location.....	6
Dispenser Installation.....	6-8
Installing CO ₂ Supply.....	9
Dispenser Setup.....	10-11
Adjust Syrup/Water Ratio.....	11

BEFORE GETTING STARTED

Each unit is tested under operating conditions and is thoroughly inspected before shipment. At the time of shipment, the carrier accepts responsibility for the unit. Upon receiving the unit, carefully inspect the carton for visible damage. If damage exists, have the carrier note the damage on the freight bill and file a claim with carrier. Responsibility for damage to the dispenser lies with the carrier.

CLEANING AND SANITIZING.....	12-14
General Information.....	12
Cleaning and Sanitizing Solutions.....	12
Scheduled Maintenance/Cleaning.....	13
Cleaning and Sanitizing Nozzles.....	13
Cleaning and Sanitizing Syrup Lines-Bag in Box.....	13
Cleaning and Sanitizing Ice Bin Compartment.....	14
TROUBLESHOOTING.....	14-17
Dispenser Troubleshooting.....	14-16
Remote Syrup Pump Troubleshooting.....	17
DISPENSER DISPOSAL.....	17
ILLUSTRATIONS AND PART LISTINGS.....	18-21
Lancer Ice Cooled Dispenser - Accessories.....	18
Series 2300 Standard Performance.....	19
Plumbing Diagrams.....	20
Tower Plumbing Diagrams.....	21
Wiring Diagram.....	21
Counter Cut-out Diagram.....	22

READ ALL SAFETY INSTRUCTIONS BEFORE USING THIS UNIT.

This manual contains important safety information and all applicable safety precautions must be observed. To reduce the risk of fire, electric shock, damage to the equipment or personal injury when using this unit all instructions/warnings on the product being used must be followed:

⚠ WARNING

Text following the Warning signal indicates a hazardous situation, which if not avoided, will result in death or serious injury. Be sure to read all Warning statements before proceeding with the installation.

⚠ CAUTION

Text following the Caution signal indicates a hazardous situation, which if not avoided, could result in death or serious injury. Be sure to read the Caution statements before proceeding with the installation.

⚠ ATTENTION

Text following the Attention signal addresses a situation that if not followed could potentially damage the equipment. Be sure to read the Attention statements before proceeding.

NOTE

Text following the Note signal provides you with information that may help you more effectively perform the installation procedures within this manual. Disregarding information will not cause damage or injury, however it may limit the performance of the dispenser.

IMPORTANT SAFETY INSTRUCTIONS

Intended Use

- The dispenser is for indoor use only
- This appliance is intended to be used in commercial applications such as restaurants or similar.
- This appliance should not be used by children or infirm persons without supervision.
- This appliance is not intended for use by persons (including children) with reduced physical sensory or mental capabilities, or lack of experience and knowledge, unless they have been given supervision or instruction concerning use of the appliance by a person responsible for their safety.
- This appliance can be used by children aged from 8 years and above and persons with reduced physical, sensory or mental capabilities or lack of experience and knowledge if they have been given supervision or instruction concerning use of the appliance in a safe way and understand the hazards involved.
- Cleaning and user maintenance shall not be performed by children without supervision.
- This unit is not a toy and children should be advised not to play with the appliance.
- The min/max ambient operating temperature for the dispenser is 40°F to 90°F (4°C to 32°C).
- Do not operate unit below minimum ambient operation conditions.
- Should freezing occur, cease operation of the unit and contact authorized service technician.
- The maximum tilt for safe operation is 5°.
- This appliance must be installed and serviced by a professional.

Carbon Dioxide (CO₂)

- **WARNING:** Carbon Dioxide (CO₂) is a colorless, noncombustible gas with a light pungent odor. High percentages of CO₂ may displace oxygen in the blood.
- **WARNING:** Prolonged exposure to CO₂ can be harmful. Personnel exposed to high concentrations of CO₂ gas will experience tremors which are followed by a loss of consciousness and suffocation.
- **WARNING:** If a CO₂ gas leak is suspected, immediately ventilate the contaminated area before attempting to repair the leak.
- **WARNING:** Strict attention must be observed in the prevention of CO₂ gas leaks in the entire CO₂ and soft drink system.

Power

- Follow all local electrical codes when making connections.
- Check the dispenser name plate label, located behind the splash plate, for the correct electrical requirements of unit. **DO NOT** plug into a wall electrical outlet unless the current shown on the serial number plate agrees with local current available.
- Each dispenser must have a separate electrical circuit.
- **DO NOT** use extension cords with this unit.
- **DO NOT** 'gang' together with other electrical devices on the same outlet.
- **WARNING:** Always disconnect electrical power to the unit to prevent personal injury before attempting any internal maintenance.
- The resettable breaker switch should not be used as a substitute for unplugging the dispenser from the power source to service the unit.
- Only qualified personnel should service internal components of electrical control housing.
- **WARNING:** Make sure that all water lines are tight and units are dry before making any electrical connections
- If this dispenser is installed in an area that is susceptible to ±10% variation of the nominal line voltage, consider installing a surge protector or similar protection device.

Water Notice

- Provide an adequate, potable water supply. Water pipe connections and fixtures directly connected to a potable water supply must be sized, installed, and maintained according to federal, state, and local codes.
- The water supply line must be at least a 3/8 inches (9.525 mm) pipe with a minimum of 25 PSI (0.172 MPa) line pressure, but not exceeding a maximum of 65 PSI (0.448 MPa). Water pressure exceeding 65 PSI (0.448 MPa) must be reduced to 65 PSI (0.448 MPa).
- Use a filter in the water line to avoid equipment damage and beverage off-taste. Check the water filter periodically, as required by local conditions.
- **CAUTION:** The water supply must be protected by means of an air gap, a backflow prevention device (located upstream of the CO₂ injection system or another approved method to comply with NSF standards. A leaking inlet water check valve will allow carbonated water to flow back through the pump when it is shut off and contaminate the water supply.
- **CAUTION:** Ensure the backflow prevention device complies with ASSE and local standards. It is the responsibility of the installer to ensure compliance.

SPECIFICATIONS AND FEATURES

ICD 2300 Standard Performance

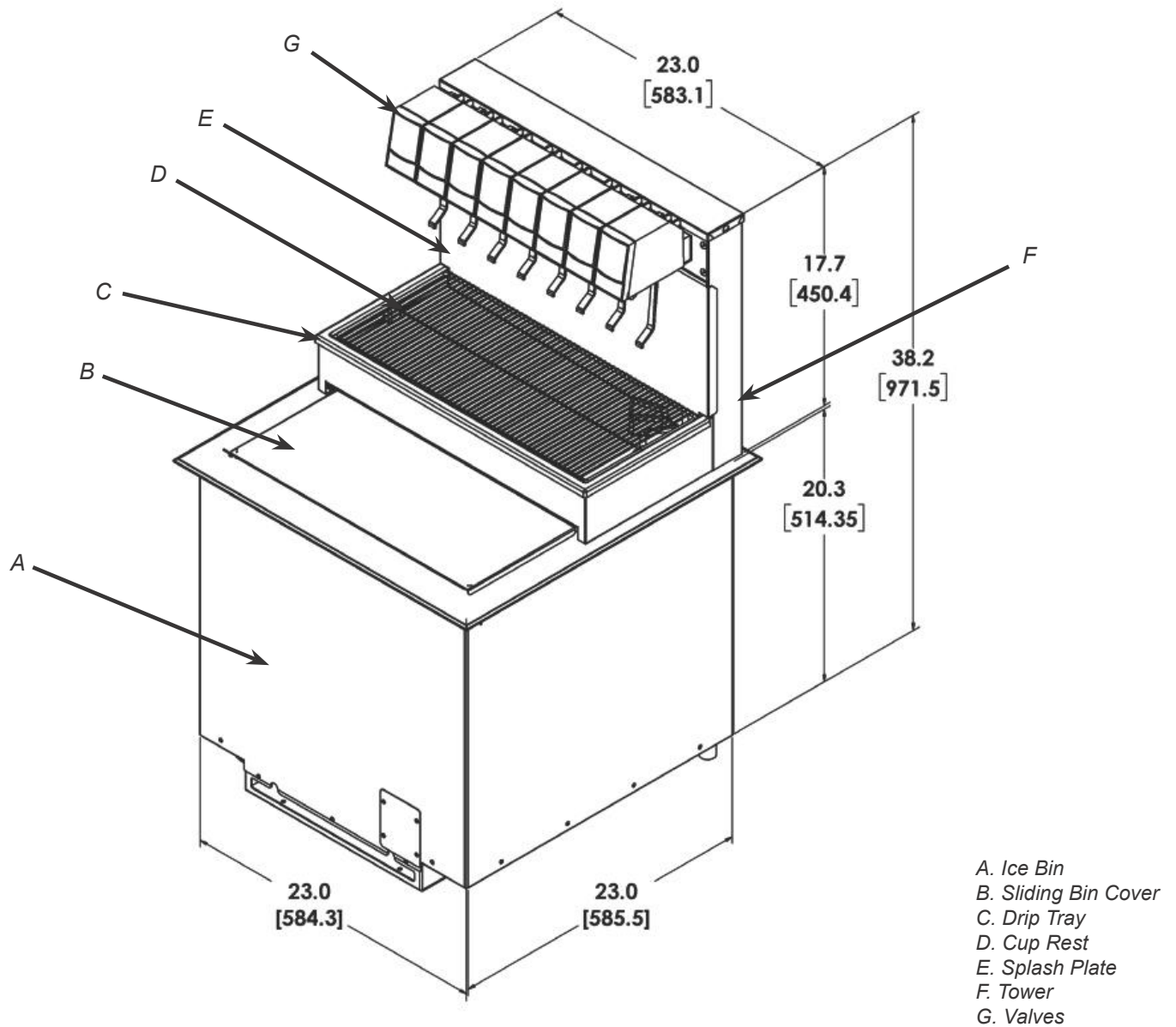

DIMENSIONS

Width: 23 inches (584 mm)
 Depth: 23 inches (584 mm)
 Height: 36.25 inches (921 mm)

WEIGHT

Shipping: 260 lbs (118 kg)
 Operating (with Ice): 206 lbs (93 kg)
 Ice Capacity: 100 lbs (45 kg)

PLAIN WATER SUPPLY

Min Flowing Pressure: 25 psi (0.172 MPa)
 Min Flowing Pressure: 50 psi (0.345 MPa)

COUNTER CUT-OUT

Width: 23.25 inches (591 mm)
 Depth: 23.25 inches (591 mm)

ELECTRICAL

115 VAC / 60 Hz

CARBON DIOXIDE (CO₂) SUPPLY

Min Pressure: 90 psi (0.621 MPa)
 Max Pressure: 110 psi (0.758 MPa)

FITTINGS

Carbonated Water Inlet: 3/8 inch barb
 Brand Syrup Inlets: 3/8 inch barb

This unit emits a sound pressure level below 70 dB

General System Overview - Remote Syrup Pumps

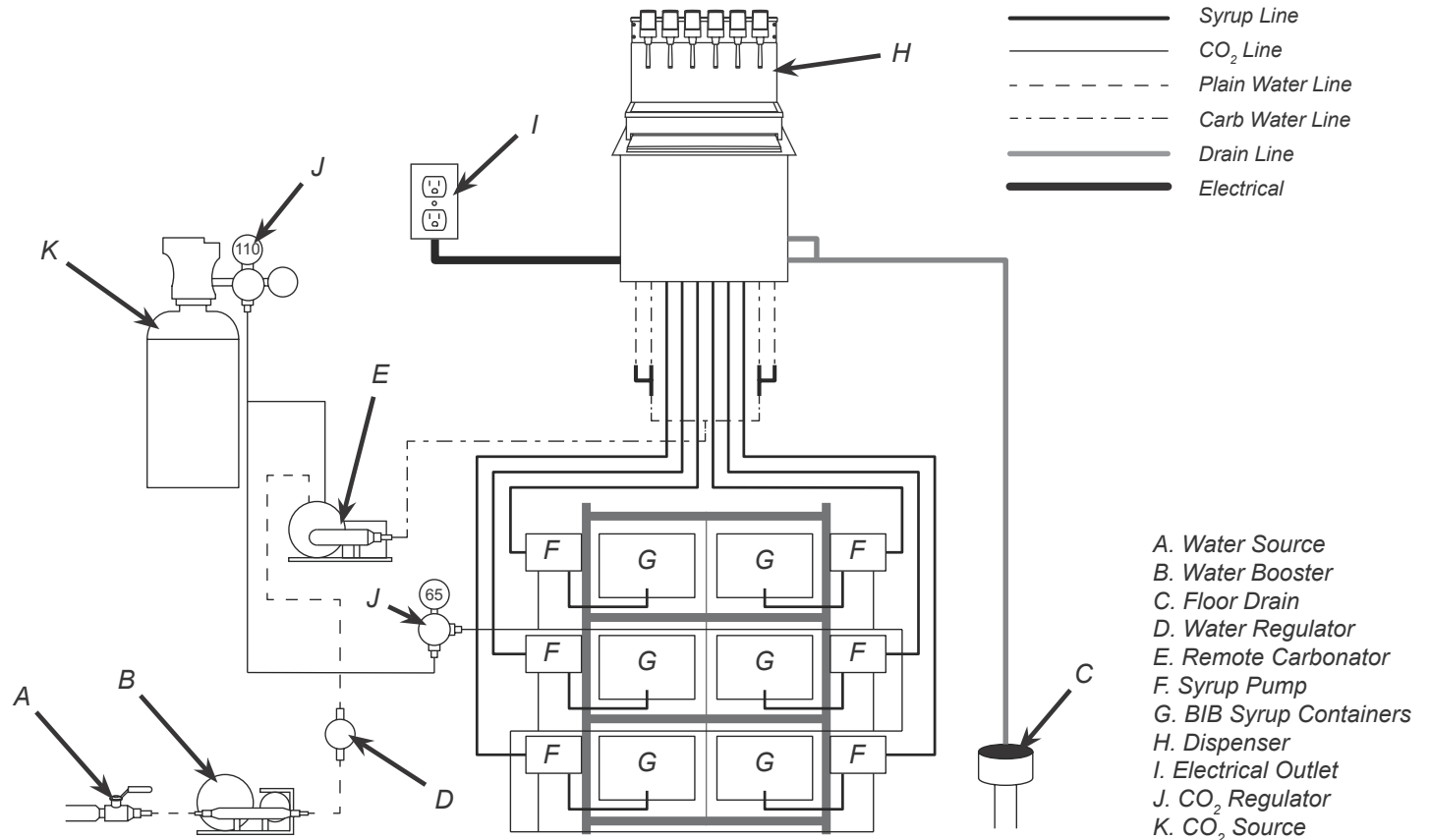

Pre-Installation Checklist

TOOLS REQUIRED:

- Oetiker Pliers
- Tubing Cutters
- Wrench
- Slotted Screwdriver
- Phillips Screwdriver
- Drill

BIB SYSTEM:

- BIB Rack
- BIB Syrup Boxes
- BIB Regulator Set
- BIB Connectors

POST MIX ACCESSORIES:

- High Pressure CO₂ Regulator
- Low Pressure CO₂ Regulator Manifold
- CO₂ Supply
- Chain for CO₂ Tank
- Beverage Dispenser
- Beverage Tubing
- Oetiker Clamp Fittings
- Water Booster (Lancer PN: 82-3401 or MC-163172)
- Water Regulator (supplied with unit)

CONSIDER THE FOLLOWING BEFORE INSTALLATION:

- Location of Water Supply Lines
- Location of Drain
- Location of Electrical Outlet
- Location of Heating and Air Conditioning Ducts
- Do you have enough space to install the dispenser?
- Is counter-top level?
- Can the counter-top support the weight of the dispenser? (Include the weight of an ice machine plus weight of ice, if necessary)
- Is dispenser located away from direct sunlight or overhead lighting?

INSTALLATION

Read This Manual

This manual was developed by Lancer Corporation as a reference guide for the owner/operator and installer of this dispenser. Please read this manual before installation and operation of this dispenser. See pages 14 - 17 for troubleshooting or service assistance. If the service cannot be corrected please call your Service Agent or Lancer Customer Service. Always have your model and serial number available when you call.

Unpacking the Dispenser

1. Set shipping carton upright on the floor then cut package banding straps and remove.
2. Open top of carton and remove interior packaging.
3. Lift carton up and off of the unit.
4. Remove accessory kit and loose parts from ice compartment.

NOTE

If unit is to be transported, it is advisable to leave the unit secured to the plywood shipping base.

⚠ WARNING

To avoid personal injury or damage, do not attempt to lift a unit without help. For heavier units, use of a mechanical lift may be appropriate. Units are equipped with automatic agitation. The unit may activate unexpectedly. Do not place hands, or foreign objects into the ice storage compartment. Unplug dispenser from the power source, when unit is being serviced, cleaned, or sanitized.

Selecting/Preparing a Counter Location

NOTE

The dispenser should only be installed in a location where it can be overseen by trained personnel

1. Select a level, well ventilated location that is in close proximity to a properly grounded electrical outlet, within five (5) feet (1.5 m) of a drain, a water supply that meets the requirements shown in the Specifications section found on pages 4-6, and away from direct sunlight or overhead lighting
2. The selected location should be able to support the weight of the dispenser and ice after the counter cut out is made. Total weight (with ice) for this unit could exceed 400 pounds (181.4 kg).

3. If installed directly on the counter, unit must be sealed to the counter-top with an FDA approved sealant.
4. If installed using the free-standing conversion kit (Lancer PN: 84-0058), unit must use the legs provided.

NOTE

NSF listed units must be sealed to the counter or use legs provided.

5. Select a location for the remote carbonator, syrup pumps, CO₂ tank, syrup containers, and water filter (recommended).

Dispenser Installation

NOTE

The installation, and relocation if necessary, must be carried out by qualified personnel with up-to-date knowledge and practical experience, in accordance with current regulations.

1. Inspect the location where the unit is to be installed and if necessary make counter cut-out, (See *Specifications* section on pages 4 or Cut-out Diagrams on page 19 for counter cut-out dimensions).

⚠ ATTENTION

Counter cut-out must be accurate, according to unit specifications.

2. Once the counter cut-out is made, lower the unit into the counter and seal the rim to the counter using an approved silicone sealant.

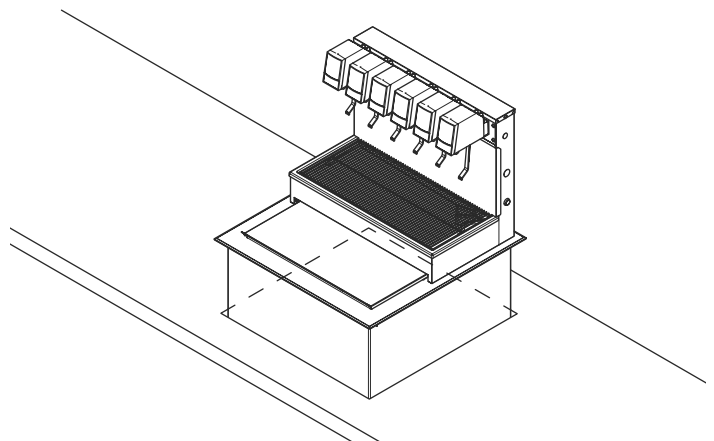

3. If using freestanding conversion kit, install per kit instructions then insert and seal unit to freestanding frame. Position freestanding unit in designated location.

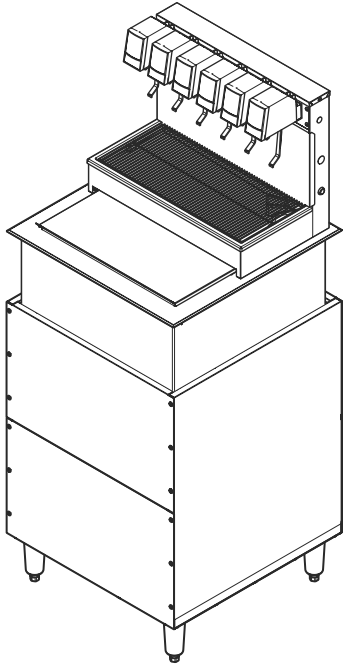

4. Route appropriate tubing from the water source to the soda water inlets at the front of the unit.
5. Install tee fitting to water line split water line between the left and right side soda water inlets.

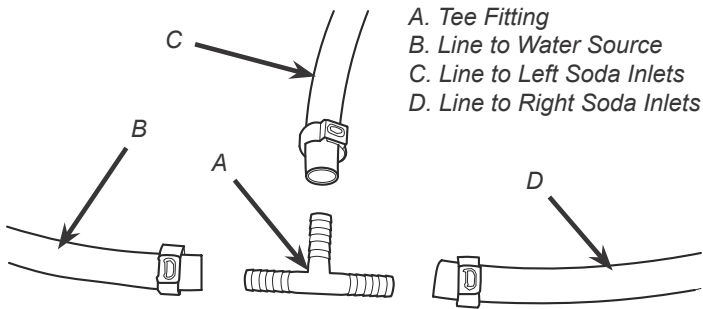

6. Install "U" fitting to each soda water line to complete soda water line manifold.

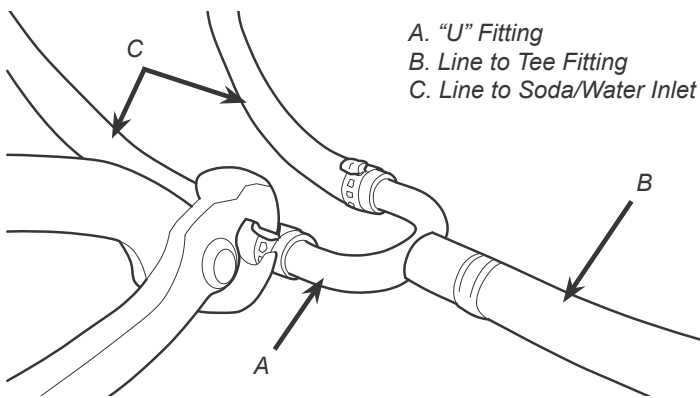

7. Route the soda water line manifold through the shipping riser legs in the back of the unit.

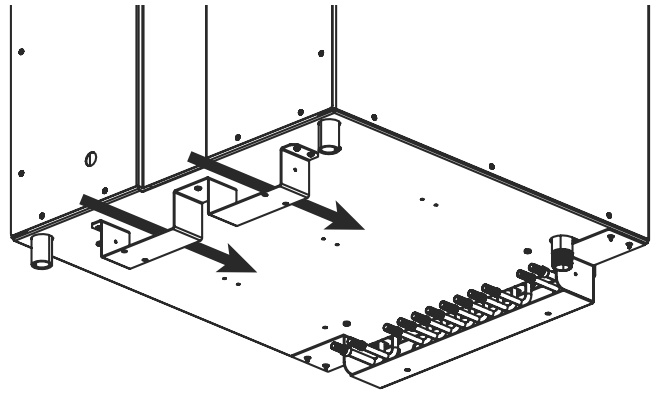

NOTE

If necessary, shipping riser can be shifted to the center of the bottom plate for ease of installation.

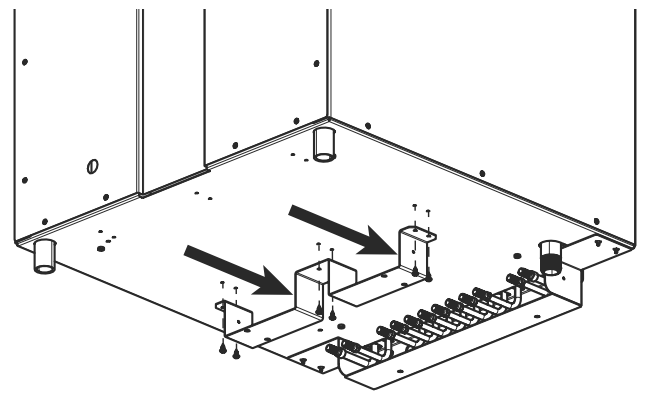

8. Connect tubing of soda water line manifold to appropriate inlets, at the front of the unit, using oetiker pliers and fittings, (see *Plumbing Diagrams* on the front of the unit or on pages 20-21 for reference).

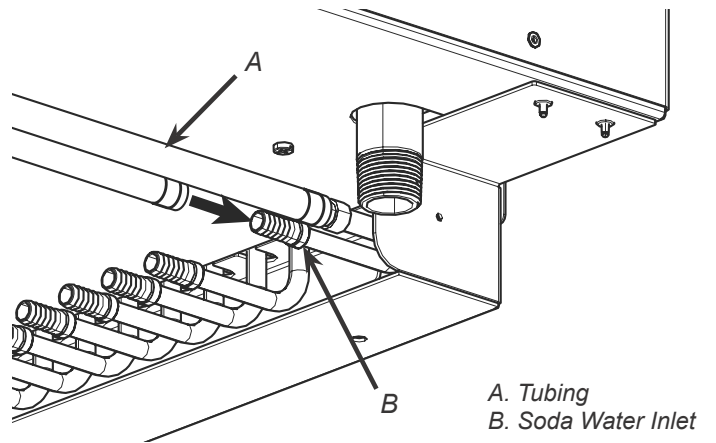

9. Connect tubing to water source then flush water lines to check for leaks.
10. Install water regulator and filter to water line and, if necessary, install water booster (Lancer PN MC-163172) between water supply and the unit.
11. Using tubing cutters, cut soda water line and install remote carbonator per manufacturer's specifications, (see *General System Overview* on page 5 for reference).
12. Install a shut-off valve in the water line feeding the carbonator pump deck.

- Route appropriate tubing from the syrup pump location through the shipping riser legs in the back of the unit (See Step 7 on previous page).
- Connect each syrup line to appropriate syrup inlet in the front of the unit (see *Plumbing Diagrams* on the front of the unit or on pages 20-21 for reference).

⚠ ATTENTION

If installing a 6-Valve unit, two of the syrup lines will be capped. DO NOT remove the caps from the two syrup lines. See plumbing diagram for reference.

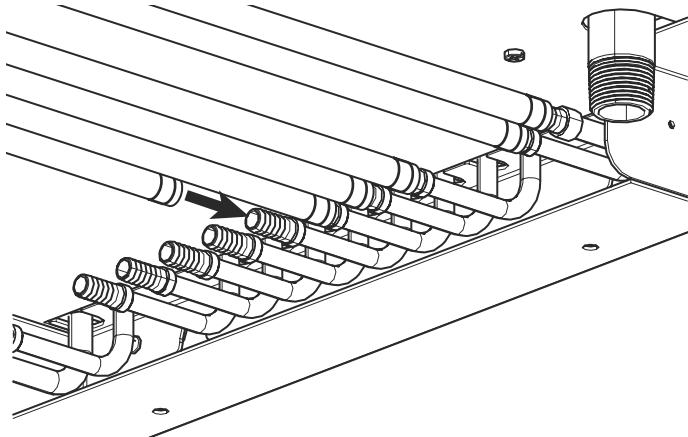

- Connect each syrup line to individual syrup pump outlet fitting.
- Install BIB (bag in box) connectors to the syrup supply line tubing.

⚠ ATTENTION

Use proper connector for syrup manufacturer

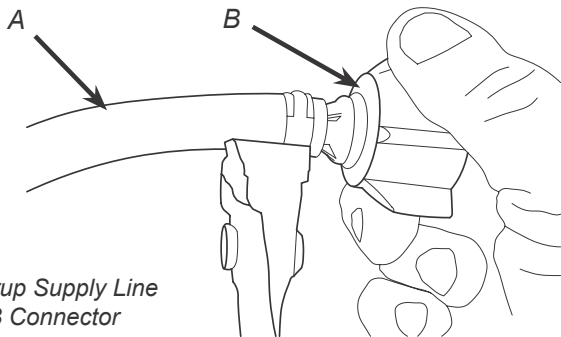

A. Syrup Supply Line
B. BIB Connector

- Attach BIB connectors on syrup supply line to BIB. Repeat for each syrup line/pump.

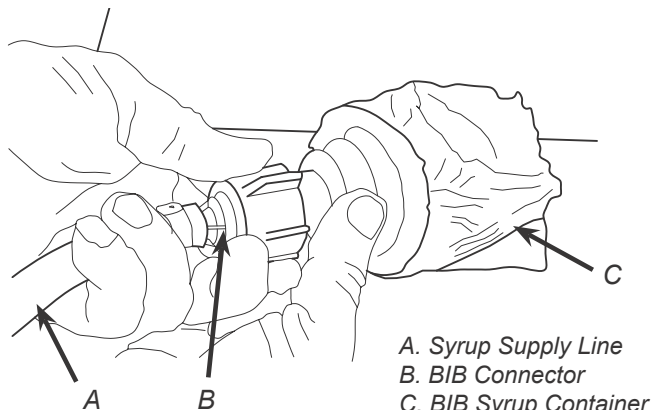

A. Syrup Supply Line
B. BIB Connector
C. BIB Syrup Container

- Install threaded drain fitting (PN: 01-1612), included in accessory kit, to front drain line.

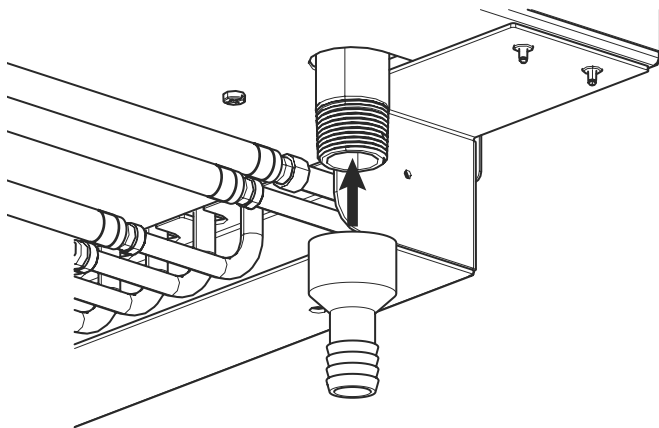

- Install PVC drain fitting to back left ice bin drain line.

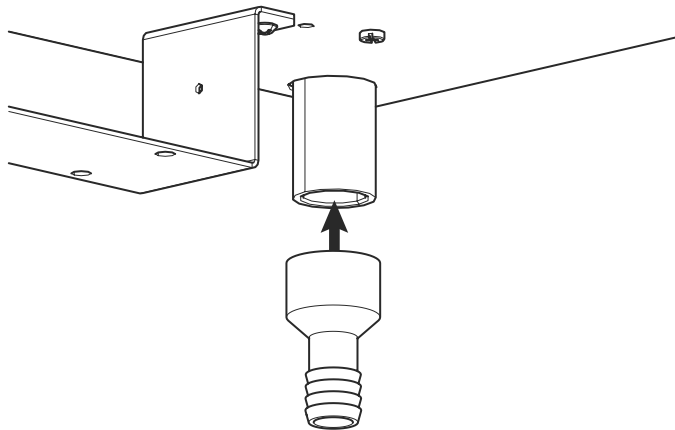

- Install drain lines to both front and back drain fittings then tee the two drain lines together at the back of the unit.
- Route tee'd drain hose to designated open type drain.

⚠ CAUTION

Drain line must be insulated with a closed cell insulation. Insulation must cover the entire length of the drain hose, including fittings. The drain should be installed in such a manner that water does not collect in sags or other low points, as condensation will form.

⚠ ATTENTION

Pouring hot water down the drain may cause the Drain Tube to collapse. Allow only warm or cold water to enter the Drain Tube. Pouring coffee, tea, or other similar substances down the drain may cause the Drain Tube to become clogged.

- Install power supply assembly to bottom plate of free standing conversion kit or under counter.
- Route the power supply cord to a grounded electrical outlet of the proper voltage and amperage rating.

⚠ WARNING

DO NOT PLUG UNIT INTO GROUNDED ELECTRICAL OUTLET AT THIS TIME. Make sure that all water lines are tight and unit is dry before making any electrical connections

Installing CO₂ Supply

1. Connect high pressure CO₂ regulator assembly to CO₂ cylinder or bulk system.

⚠ ATTENTION

Before installing regulator, assure that a seal (washer or o-ring) is present in regulator attachment nut.

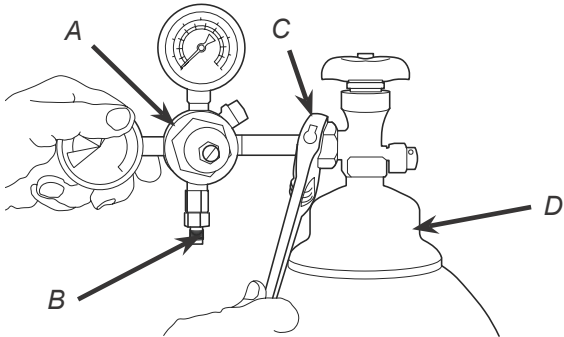

A. CO₂ Regulator
B. Outlet
C. Wrench
D. CO₂ Supply

- Thread regulator nut on to tank, then tighten nut with wrench

2. Connect appropriate CO₂ tubing to inlet on regulator then route tubing from the CO₂ regulator to the remote carbonator and CO₂ regulator at syrup pumps. Use a tee fitting if necessary.

⚠ ATTENTION

A dedicated CO₂ regulator is required to supply the carbonator as well as to all syrup pumps.

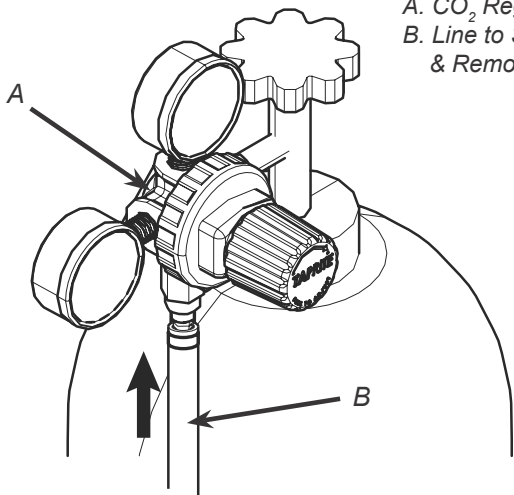

A. CO₂ Regulator
B. Line to Syrup Pumps & Remote Carbonator

3. Route appropriate tubing for CO₂ from CO₂ regulator at syrup pumps to all syrup pump CO₂ inlets.

⚠ WARNING

DO NOT TURN ON CO₂ SUPPLY AT THIS TIME

4. Turn the knob on the CO₂ regulator, at the source, all the way to the left (counterclockwise) to close the regulator. Repeat for CO₂ regulator at the syrup pumps.

A. CO₂ Regulator
B. Regulator Knob

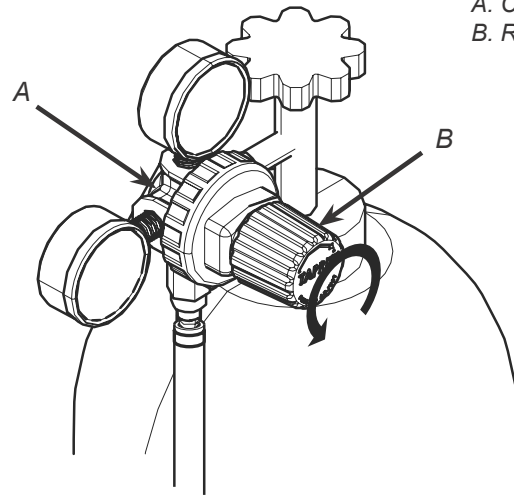

NOTE

If regulator does not utilize a knob, use a wrench to loosen the lock nut then a screwdriver to back out the screw and close the regulators.

A. CO₂ Regulator
B. Wrench
C. Lock Nut

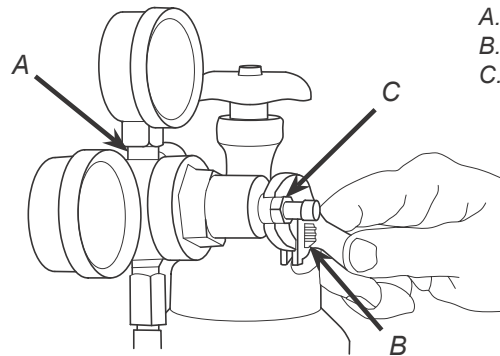

A. CO₂ Regulator
B. Screwdriver
C. Loosened Lock Nut
D. Regulator Adjustment Screw

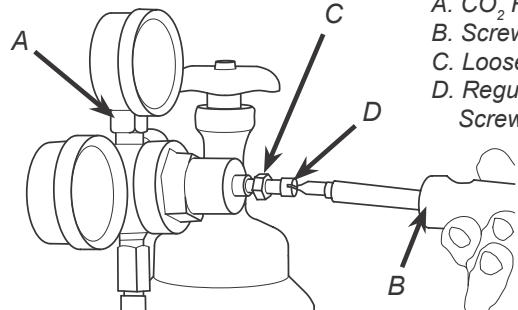

Dispenser Setup

1. Turn on water source.
2. Place enough ice in the ice bin to fill approximately 1/2 of the bin before plugging in the unit.
3. Connect unit power cord to grounded electrical outlet.

⚠ WARNING

The dispenser must be properly electrically grounded to avoid serious injury or fatal electrical shock. The power cord has a three-prong grounded plug. If a three-hole grounded electrical outlet is not available, use an approved method to ground the unit. Follow all local electrical codes when making connections. Each dispenser must have a separate electrical circuit. Do not use extension cords. Do not connect multiple electrical devices on the same outlet.

4. Open the pressure relief valve, located on the remote carbonator, by flipping up on the valve cap lever. Hold open until water flows from the relief valve then close (flip down) the relief valve.

A. Pressure Relief Valve

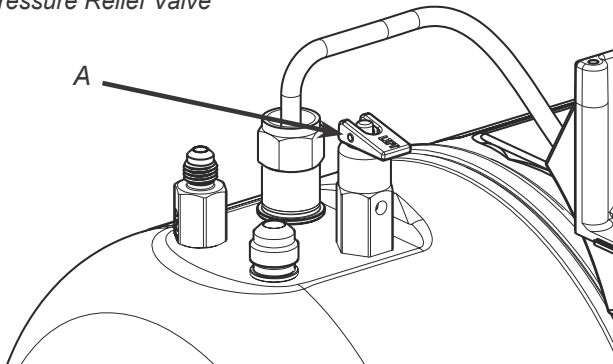

5. Activate each valve to ensure a good flow of water is achieved.
6. Ensure carbonator pump deck is turned OFF before turning on CO₂.

⚠ ATTENTION

Failure to disconnect the motor power supply will damage the carbonator motor, the pump and void the warranty.

7. Turn on CO₂ at the source then turn the knob on the CO₂ regulator at source to the right (clockwise) until regulator reads 105 psi (0.724 MPa).

⚠ ATTENTION

DO NOT ADJUST CO₂ REGULATOR AT SYRUP PUMPS AT THIS TIME. Make sure carbonated water flow rate is set before adjusting regulator at syrup pumps.

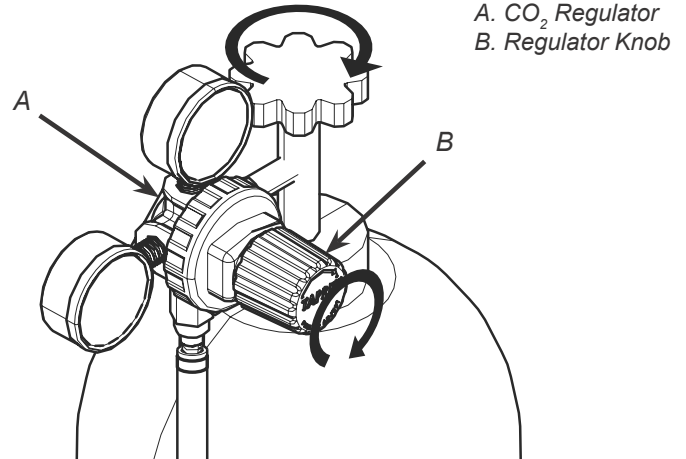

A. CO₂ Regulator
B. Regulator Knob

NOTE

If regulator does not utilize a knob, use a screwdriver to adjust regulator to 105 psi (0.724 MPa) then tighten lock nut with wrench.

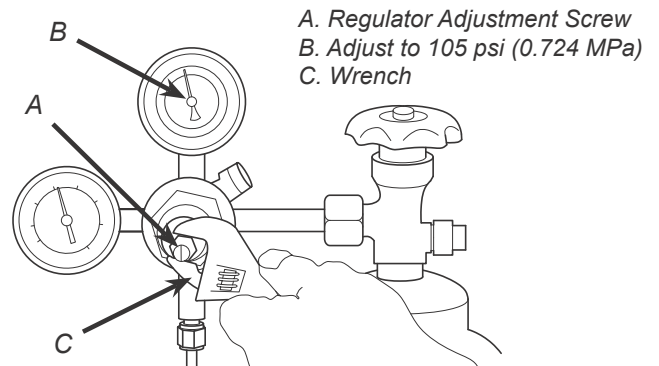

A. Regulator Adjustment Screw
B. Adjust to 105 psi (0.724 MPa)
C. Wrench

8. Activate each valve until gas-out.
9. Plug in the remote carbonator pump deck, if not already done so, and turn the switch to the ON position.
10. Activate each valve until the carbonator pump comes on. Release the button, allow carbonator to fill and stop. Repeat this process until a steady flow of carbonated water is achieved.

NOTE

The pump deck has a 3 minute timeout feature. If the timeout occurs, turn the deck OFF then ON by flipping the switch on the control box.

NOTE

To check for CO₂ leaks, close the valve on the CO₂ cylinder and observe if the pressure to the system drops with the cylinder valve closed for five minutes. Open the cylinder valve after check.

11. Remove the Valve ID Panel for the first valve.

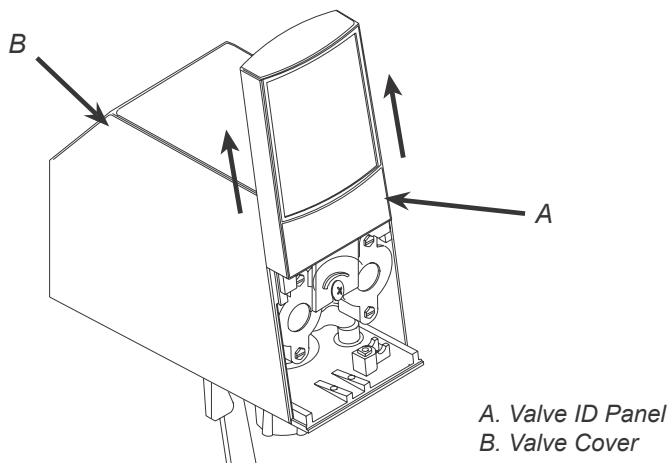

NOTE

Ensure there is ice on the cold plate and the lines are cold before attempting to set the flow rates on the valves. The drink temperature should be no higher than 40°F (4.4°C) when flow rates are set.

12. Use a Lancer ratio cup to verify water flow rate (5 oz. in 4 sec.). Use a screwdriver to adjust if needed.

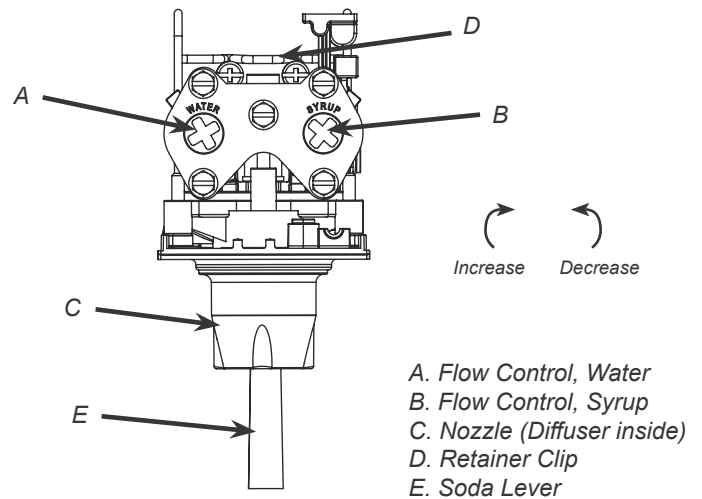

13. Repeat Step 12 until flow rate is correct.

14. Repeat Steps 11 - 13 for remaining valves.

Adjust Syrup/Water Ratio

1. Turn the knob on the CO₂ regulator at the syrup pumps to the right (clockwise) until regulator reads 65 psi (0.448 MPa).

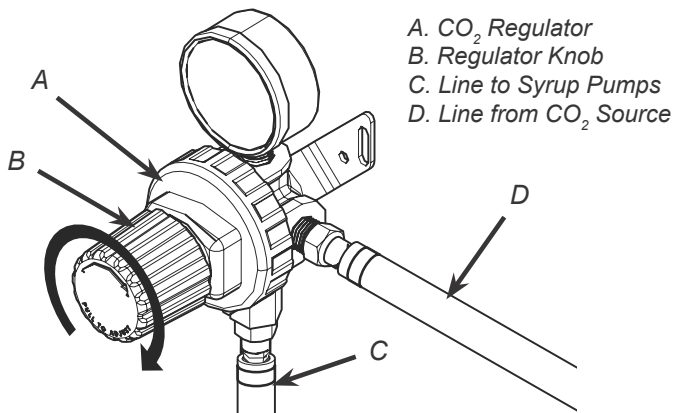

NOTE

If regulator does not utilize a knob, use a screwdriver to adjust regulator to 65 psi (0.448 MPa) then tighten lock nut with wrench.

2. Remove nozzle on first valve by twisting counter clockwise and pulling down

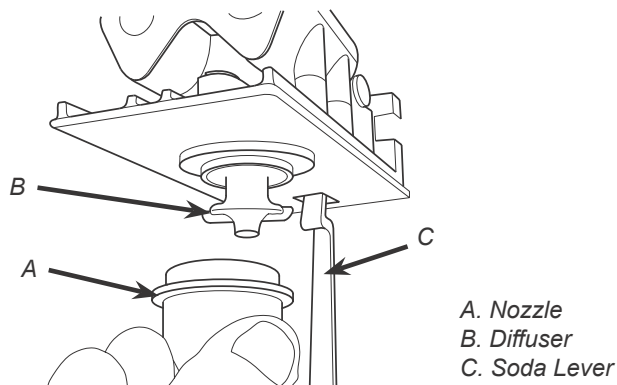

3. Remove the diffuser by pulling down.

4. Install Lancer (yellow) syrup separator (PN 54-0031) in place of nozzle.

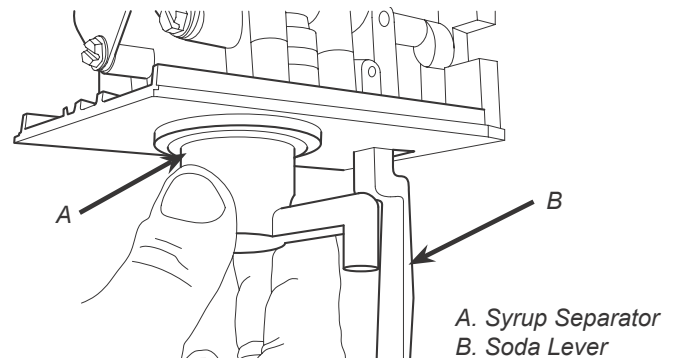

5. Using a Lancer ratio cup, activate the valve and capture a sample. Verify that the syrup level is even with the water level. Use a screwdriver to adjust if needed.

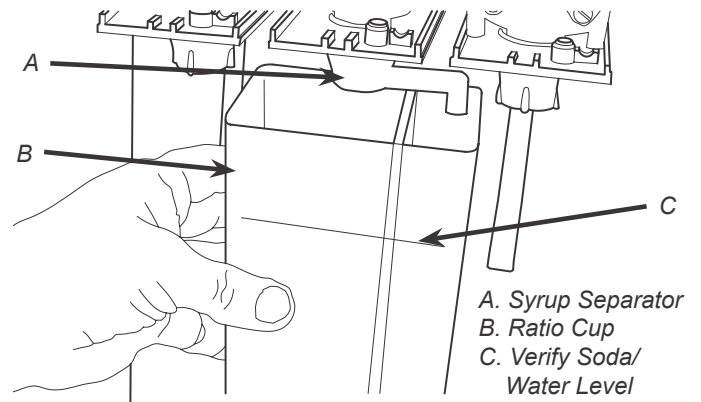

6. Remove syrup separator and reinstall nozzle. Replace valve ID cover.

7. Repeat steps 2-6 for each valve.

CLEANING AND SANITIZING

General Information

- Lancer equipment (new or reconditioned) is shipped from the factory cleaned and sanitized in accordance with NSF guidelines. The operator of the equipment must provide continuous maintenance as required by this manual and/or state and local health department guidelines to ensure proper operation and sanitation requirements are maintained.

NOTE

The cleaning procedures provided herein pertain to the Lancer equipment identified by this manual. If other equipment is being cleaned, follow the guidelines established by the manufacturer for that equipment.

- Cleaning should be accomplished only by trained personnel. Sanitary gloves are to be used during cleaning operations. Applicable safety precautions must be observed. Instruction warnings on the product being used must be followed.

⚠ ATTENTION

- Use sanitary gloves when cleaning the unit and observe all applicable safety precautions.
- **DO NOT** use a water jet to clean or sanitize the unit.
- **DO NOT** disconnect water lines when cleaning and sanitizing syrup lines, to avoid contamination.
- **DO NOT** use strong bleaches or detergents; These can discolor and corrode various materials.
- **DO NOT** use metal scrapers, sharp objects, steel wool, scouring pads, abrasives, or solvents on the dispenser.
- **DO NOT** use hot water above 140° F (60° C). This can damage the dispenser.
- **DO NOT** spill sanitizing solution on any circuit boards. Insure all sanitizing solution is removed from the system.

Cleaning and Sanitizing Solutions

Cleaning Solution

Mix a mild, non-abrasive detergent (e.g. Sodium Laureth Sulfate, dish soap) with clean, potable water at a temperature of 90°F to 110°F (32°C to 43°C). The mixture ratio is one ounce of cleaner to two gallons of water. Prepare a minimum of five gallons of cleaning solution. Do not use abrasive cleaners or solvents because they can cause permanent damage to the unit. Ensure rinsing is thorough, using clean, potable water at a temperature of 90°F to 110°F. Extended lengths of product lines may require additional cleaning solution.

⚠ WARNING

If a powder sanitizer is used, dissolve it thoroughly with hot water prior to adding to the syrup system. Ensure sanitizing solution is removed from the dispenser as instructed. Avoid getting sanitizing solution on circuit boards. Do not use strong bleaches or detergents; these can discolor and corrode various materials. Do not use metal scrapers, sharp objects, steel wool, scouring pads, abrasives, or solvents on the dispenser. Do not use hot water above 140° f (60° c). This can damage the dispenser.

Sanitizing Solution

Prepare the sanitizing solution in accordance with the manufacturer's written recommendations and safety guidelines. The type and concentration of sanitizing agent recommended in the instructions by the manufacturer shall comply with 40 CFR §180.940. The solution must provide 100 parts per million (PPM) chlorine (e.g. Sodium Hypochlorite or bleach) and a minimum of five gallons of sanitizing solution should be prepared.

Scheduled Maintenance/Cleaning

As Needed	<ul style="list-style-type: none"> Keep exterior surfaces of unit clean using a clean, damp cloth.
Daily	<ul style="list-style-type: none"> Using the cleaning solution, clean all exterior stainless steel surfaces. Clean exterior of dispensing valves and ice chute. Remove cup rest then clean the drip tray and cup rest. Replace cup rest when finished. Wipe clean all splash areas using a damp cloth soaked in cleaning solution. Clean beverage nozzles as specified by the section "Cleaning and Sanitizing Nozzles".
Monthly	<ul style="list-style-type: none"> Clean the ice bin as specified by the section "Cleaning and Sanitizing Ice Bin Compartment" on the next page.
Every Six Months	<ul style="list-style-type: none"> Clean the syrup lines as specified by the section "Cleaning and Sanitizing Syrup Lines - Bag in Box" on the next page. Check for any loose components or noises.

Cleaning and Sanitizing Nozzles

1. Disconnect power, so as to not activate valve while cleaning.
2. Remove merchandiser to reveal valves.
3. Remove nozzle by twisting counter clockwise and pulling down.
4. Remove diffuser by pulling down.
5. Rinse nozzle and diffuser with warm water.
6. Wash nozzle and diffuser with cleaning solution then immerse in sanitizing solution and let sit for fifteen (15) minutes.
7. Set nozzle and diffuser aside and let air dry. **DO NOT** rinse with water after sanitizing.
8. Reconnect diffuser and nozzle.
9. Connect power.
10. Taste the drink to verify that there is no off-taste. If off-taste is found, flush syrup system again.

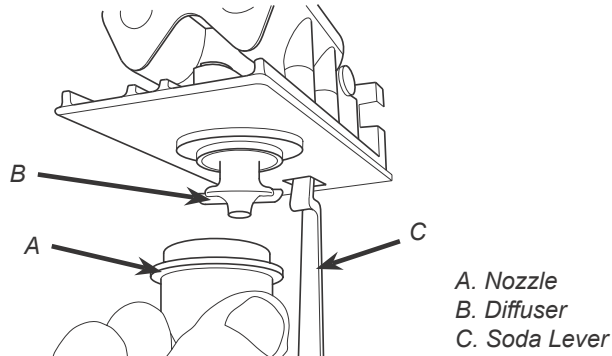

⚠ CAUTION

Following sanitation, rinse with end-use product until there is no aftertaste. Do not use a fresh water rinse. This is a NSF requirement. Residual sanitizing solution left in the system creates a health hazard.

Cleaning and Sanitizing Syrup Lines - Bag in Box

1. Disconnect syrup lines from BIB's
2. Place syrup lines, with BIB connectors, in a bucket of warm water.
3. Activate each valve to fill the lines with warm water and flush out syrup remaining in the lines.
4. Prepare Cleaning Solution described above.
5. Place syrup lines, with BIB connectors, into cleaning solution.
6. Activate each valve until lines are filled with cleaning solution then let stand for ten (10) minutes.
7. Flush out cleaning solution from the syrup lines using clean, warm water.
8. Prepare Sanitizing Solution described above.
9. Place syrup lines into sanitizing solution and activate each valve to fill lines with sanitizer. Let sit for ten (10) minutes.
10. Reconnect syrup lines to BIB's and draw drinks to flush solution from the dispenser.
11. Taste the drink to verify that there is no off-taste. If off-taste is found, flush syrup system again.

⚠ CAUTION

Following sanitation, rinse with end-use product until there is no aftertaste. Do not use a fresh water rinse. This is a NSF requirement. Residual sanitizing solution left in the system creates a health hazard.

Cleaning and Sanitizing Ice Bin Compartment

NOTE

The ice bin compartment of the dispenser should be thoroughly cleaned and sanitized at least once every month.

1. Prepare cleaning solution and sanitizing solution according to the corresponding sections on the previous page.
2. Using the cleaning solution and a clean soft cloth, wash down the sides of the ice bin and the surface of the aluminum casting.
3. Using clean, potable water, thoroughly rinse away the cleaning solution from the sides and surface of the casting.

4. Using plastic sanitary gloves, soak a white cotton gauze cleaning rag in the sanitizing solution and wipe all surfaces in the ice compartment.

CAUTION

A fresh water rinse cannot follow sanitation of equipment. Purge only with the end use product. This is an NSF requirement.

5. Sanitizing of the ice compartment is complete. Refill with ice.

TROUBLESHOOTING

Dispenser Troubleshooting

TROUBLE	CAUSE	REMEDY
No product when valve is activated.	<ol style="list-style-type: none"> 1. Key-switch is off or key-switch harness is disconnected. 2. No power to dispenser. 3. Malfunctioning switch assembly. 4. Malfunctioning power supply. 5. Malfunctioning PCB board. 6. Malfunctioning LEV valve. 	<ol style="list-style-type: none"> 1. Turn key-switch on and/or reconnect key-switch harness. 2. Check internal breaker and incoming power. 3. Replace switch assembly. 4. Check voltage to power supply. Check fuses. 5. Replace PCB board. 6. Replace valve.
Water only dispensed, no syrup. Or syrup only dispensed, no water.	<ol style="list-style-type: none"> 1. Syrup BIB empty. 2. Water or syrup shutoff on mounting block not fully open. 3. Improper or inadequate water or syrup supply. 4. CO₂ pressure to syrup pump too low. 5. Stalled or inoperative BIB pump. 6. Kinked line. 7. CO₂ regulator malfunction. 	<ol style="list-style-type: none"> 1. Replace syrup BIB as required. 2. Open shutoff completely. 3. Remove valve from mounting block & open shut-offs slightly. Check water & syrup supply. If no supply, check unit for other problems. Ensure BIB connection is engaged. 4. Check the CO₂ pressure to the pump to ensure it is between 70-80 PSI (0.483-0.552 MPa). 5. Check CO₂ pressure and/or replace pump. 6. Remove kink or replace line. 7. Repair or replace CO₂ regulator as required.
Syrup only dispensed. No water, but CO ₂ gas dispensed with syrup.	<ol style="list-style-type: none"> 1. Improper water flow to dispenser. 2. Carbonator pump motor has timed out. 3. Liquid level probe not connected properly to PCB. 4. Defective PCB assembly. 5. Defective liquid level probe. 6. Weak or defective carbonator pump. 	<ol style="list-style-type: none"> 1. Check for water flow to dispenser. 2. Reset by turning the unit OFF, then ON by using the circuit breaker on the power supply or momentarily unplugging unit. 3. Check connections of liquid level probe to PCB assembly. 4. Replace PCB assembly. 5. Replace liquid level probe. 6. Replace pump.

TROUBLE	CAUSE	REMEDY
Excessive foaming.	<ol style="list-style-type: none"> 1. No ice in bin. 2. Incoming water or syrup temperature too high. 3. CO₂ pressure too high. 4. Water flow rate too high. 5. Nozzle and diffuser not clean. 6. Air in BIB lines. 	<ol style="list-style-type: none"> 1. Fill bin with ice and allow coldplate to re-stabilize. 2. Correct prior to dispenser. 3. Adjust CO₂ pressure downward, but not less than 70 PSI (0.483 MPa). 4. Re-adjust and reset ratio. 5. Remove and clean. 6. Bleed air from BIB lines.
Off Taste in Soda.	<ol style="list-style-type: none"> 1. Leaking water check valve, allowing carbonated water to back into supply line. 	<ol style="list-style-type: none"> 1. Dismantle and clean check valve. Replace O-ring, if torn or distorted.
Valves inoperable.	<ol style="list-style-type: none"> 1. Loss of Power. 	<ol style="list-style-type: none"> 1. Check power supply to see if plugged in. Check transformer circuit breaker. Check main power circuit breaker, 110V.
Low or no carbonation.	<ol style="list-style-type: none"> 1. Low or no CO₂. 2. Low water pressure. 3. Worn or defective carbonator pump. 4. Back-flow preventer not allowing water to flow. 5. Carbonator motor not running. 6. Carbonator motor running continuously. 	<ol style="list-style-type: none"> 1. Check CO₂ supply. Adjust CO₂ pressure to 70 PSI (0.483 MPa). 2. Need water booster kit. 3. Replace carbonator pump. 4. Replace back-flow preventer, noting the flow direction arrow from pump to coldplate. 5. Check power supply. Be sure toggle switch is in ON position. 6. Check switch on carbonator. Check water in check valve for blockage. Check carbonator control. Check carbonator pump for efficiency.
Erratic ratio.	<ol style="list-style-type: none"> 1. Incoming water and/or syrup supply not at minimum flowing pressure. 2. Foreign debris in water and/or syrup flow control. 3. CO₂ regulator malfunction. 	<ol style="list-style-type: none"> 1. Check pressure and adjust. 2. Remove flow control from suspected valve and clean out any foreign material to ensure smooth spool movement. 3. Repair or replace CO₂ regulator.
Insufficient soda flow (carbonated drinks).	<ol style="list-style-type: none"> 1. Insufficient CO₂ supply pressure. 2. Shutoff on mounting block is not fully open. 3. Foreign debris in soda flow control. 	<ol style="list-style-type: none"> 1. Verify incoming CO₂ pressure is between 70 psi (0.483 MPa) and 80 psi (0.552 MPa) 2. Open shutoff fully. 3. Remove soda flow control from valve and clean out any foreign material to ensure smooth spool movement.
Insufficient water flow (plain water drinks).	<ol style="list-style-type: none"> 1. Insufficient incoming supply pressure. 2. Shutoff on mounting block not fully open. 3. Foreign debris in water flow control. 4. Water filtration problem. 	<ol style="list-style-type: none"> 1. Verify incoming supply water pressure to plain water inlet is a minimum of 50 PSI (0.345 MPa) and a maximum of 100 PSI (0.689 MPa). 2. Open shutoff fully. 3. Remove water flow control from valve and clean out any foreign material to ensure smooth spool movement. 4. Service water system as required.

TROUBLE	CAUSE	REMEDY
Insufficient syrup flow.	<ol style="list-style-type: none"> 1. Insufficient CO₂ pressure to BIB pumps. 2. Shutoff on mounting block not fully open. 3. Foreign debris in syrup flow control. 4. Defective BIB pump. 	<ol style="list-style-type: none"> 1. Adjust CO₂ pressure to BIB pumps to 80 PSI (0.552 MPa) (min. 70 PSI (0.483 MPa). Do not exceed manufacturer's recommendations. 2. Open shutoff fully. 3. Remove syrup flow control from valve and clean out any foreign material to ensure smooth spool movement. 4. Replace pump.
Water leakage around nozzle.	<ol style="list-style-type: none"> 1. Damaged or improperly installed o-ring on nozzle. 	<ol style="list-style-type: none"> 1. If damaged, replace. If improperly installed, adjust.
Miscellaneous leakage.	<ol style="list-style-type: none"> 1. Gap between parts. 2. Damaged or improperly installed o-rings. 	<ol style="list-style-type: none"> 1. Tighten appropriate retaining screws. 2. Replace or adjust appropriate o-rings.
Water continually leaking at connections.	<ol style="list-style-type: none"> 1. Loose water connections. 2. Flare seal washer leaks. 	<ol style="list-style-type: none"> 1. Tighten water connections. 2. Replace flare seal washer.
Water in ice bin.	<ol style="list-style-type: none"> 1. Coldplate drain is obstructed. 	<ol style="list-style-type: none"> 1. Remove splash plate and drip tray to obtain access to drain tubes and clear accordingly.
Noisy/cavitating carbonator pump.	<ol style="list-style-type: none"> 1. Insufficient incoming water supply pressure. 2. Loose pump coupling. 	<ol style="list-style-type: none"> 1. Verify incoming supply water pressure to carbonator pump is min. of 25 PSI (0.172 MPa), max. of 50 PSI (0.345 MPa). Check strainer for cleanliness. 2. Tighten set screw on pump coupling.
Off Taste in Soda.	<ol style="list-style-type: none"> 1. Leaking water check valve, allowing carbonated water to back into supply line. 	<ol style="list-style-type: none"> 1. Dismantle and clean check valve. Replace O-ring, if torn or distorted.
Valves inoperable.	<ol style="list-style-type: none"> 1. Loss of Power. 	<ol style="list-style-type: none"> 1. Check power supply to see if plugged in. Check transformer circuit breaker. Check main power circuit breaker, 110V.

Remote Syrup Pump Troubleshooting

TROUBLE	CAUSE	REMEDY
BIB pump does not operate when dispensing valve is opened.	<ol style="list-style-type: none"> 1. Out of CO₂, CO₂ not turned on, or low CO₂ pressure. 2. Out of syrup. 3. BIB connector not tight. 4. Kinks in syrup or gas lines. 	<ol style="list-style-type: none"> 1. Replace CO₂ supply, turn on CO₂ supply, or adjust CO₂ pressure to 70-80 PSI (0.483-0.552 MPa). 2. Replace syrup supply. 3. Fasten connector tightly. 4. Straighten or replace lines.
BIB pump operating, but no flow.	<ol style="list-style-type: none"> 1. Leak in syrup inlet or outlet line. 2. Defective BIB pump. 	<ol style="list-style-type: none"> 1. Replace line. 2. Replace BIB pump.
BIB pump continues to operate when bag is empty.	<ol style="list-style-type: none"> 1. Leak in suction line. 2. Leaking o-ring on pump inlet fitting. 3. Defective syrup BIB pump. 	<ol style="list-style-type: none"> 1. Check BIB connector, if still leaking then replace line. 2. Replace o-ring 3. Replace defective pump.
BIB pump fails to restart after bag replacement.	<ol style="list-style-type: none"> 1. BIB connector not on tightly. 2. BIB connector is stopped up. 3. Kinks in syrup line. 	<ol style="list-style-type: none"> 1. Tighten BIB connector. 2. Clean out or replace BIB connector. 3. Straighten or replace line.
BIB pump fails to stop when dispensing valve is closed.	<ol style="list-style-type: none"> 1. Leak in discharge line or fittings. 2. Empty BIB. 3. Air leak on inlet line or bag connector. 	<ol style="list-style-type: none"> 1. Repair or replace discharge line. 2. Replace BIB. 3. Repair or replace.

Dispenser Disposal



To prevent possible harm to the environment from improper disposal, recycle the unit by locating an authorized recycler or contact the retailer where the product was purchased. Comply with local regulations regarding disposal of the refrigerant and insulation.

ILLUSTRATIONS AND PART LISTINGS

Lancer Ice Cooled Dispenser - Accessories

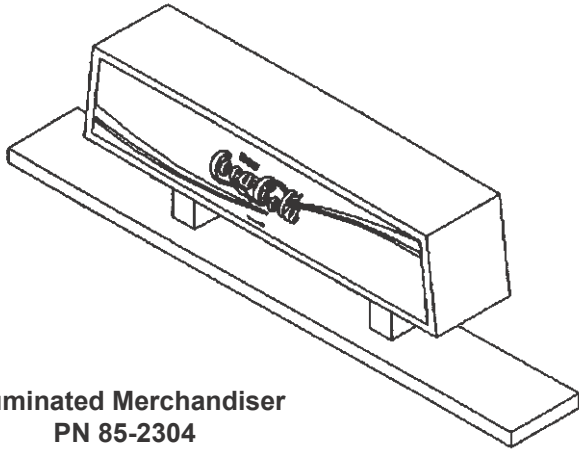

Illuminated Merchandiser
PN 85-2304

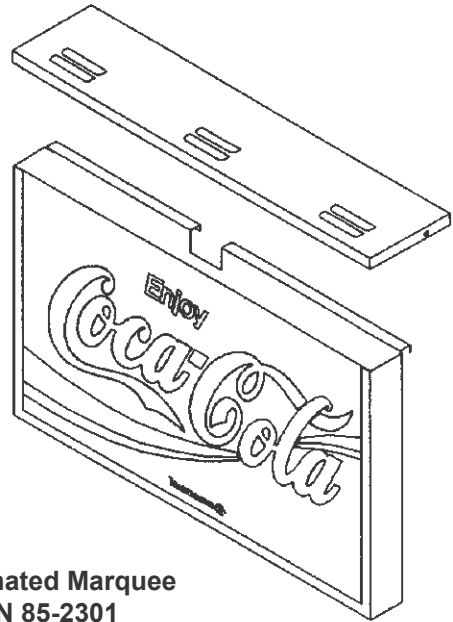

Illuminated Marquee
PN 85-2301

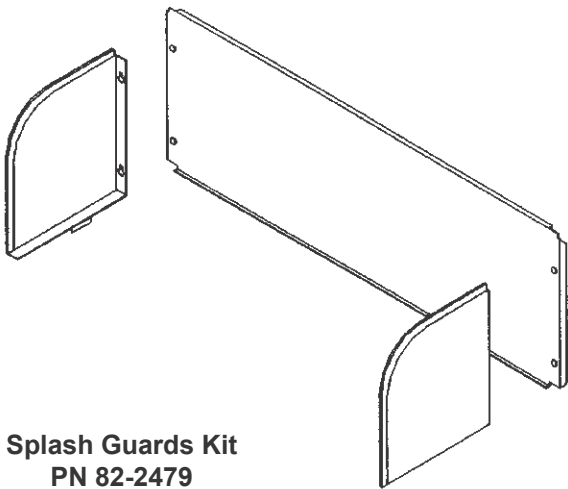

Splash Guards Kit
PN 82-2479

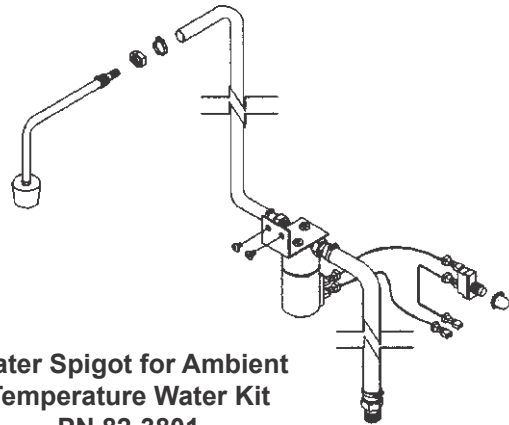

**Water Spigot for Ambient
Temperature Water Kit**
PN 82-3801

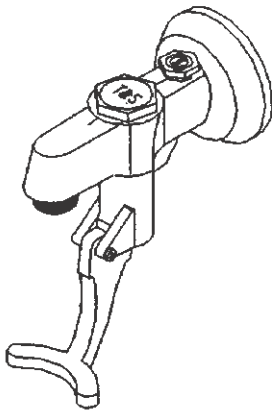

T & S Valve for Chilled Water
PN 19-0036

Series 2300 Standard Performance

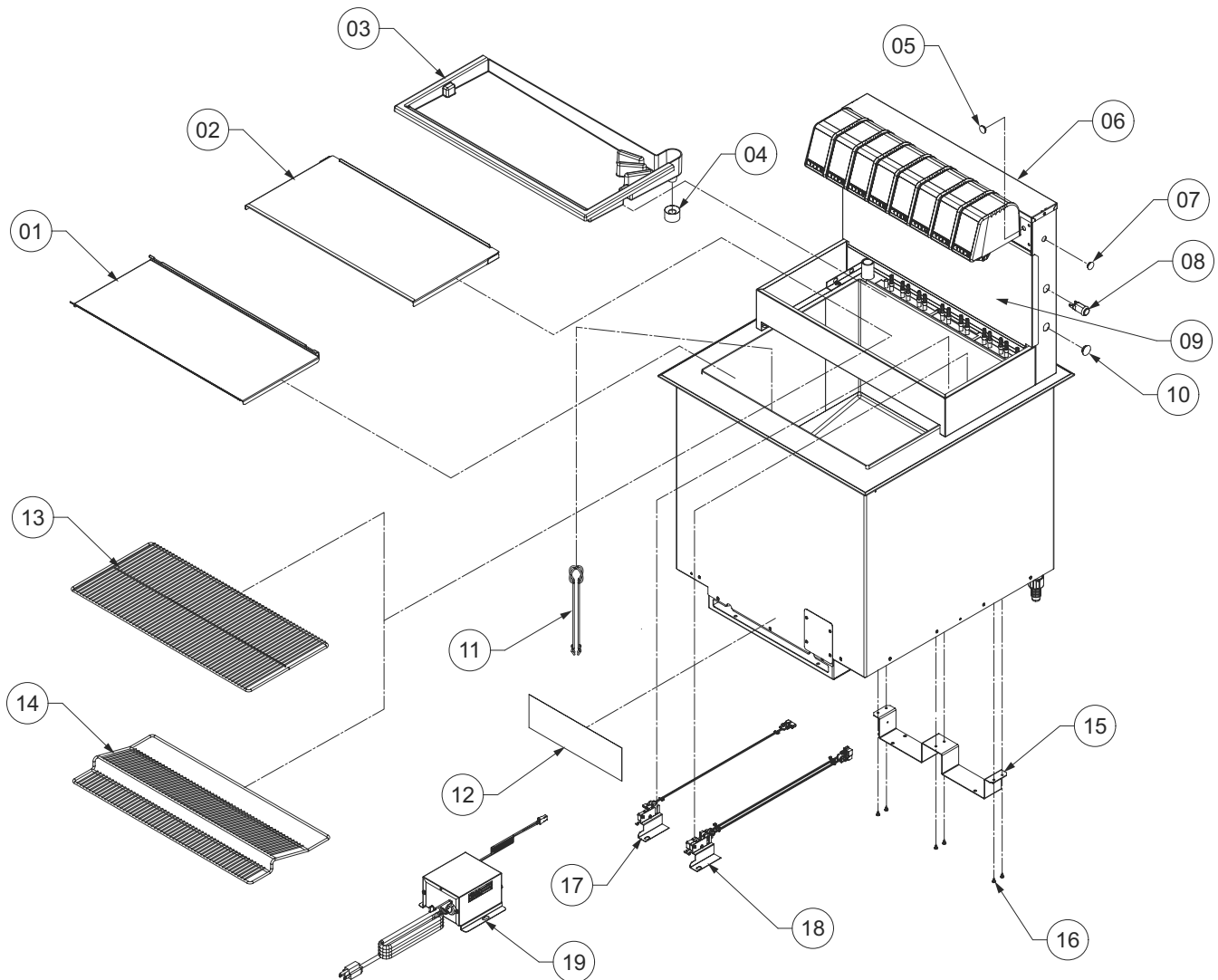

Item	Part No.	Description	Item	Part No.	Description
01	30-16124	Sliding Bin Cover, 2323 ICDI	12	06-4044	Plumbing Diagram Label, 2323 ICDI, 8 Valve, SP
02	30-16156	Sanitary Plate, 2323 ICDI	13	23-0797	Cup Rest, Wide Sabre Tower
03	05-2586	Drip Tray, 2323, CIC	14	23-1131	Cup Rest, Tilted Surefill, 23" ICDI
04	05-2467	Drip Tray Drain Coupler, IC	15	30-16082	Rear Tube Support Bracket, 2323 ICDI
05	07-0555	Hole Plug, 13/32" Dia, SS	16	04-0504	Screw, 8-18 x 0.375, PHD, w/out Washer, PH, AB, SH
06	30-12703	Cap, w/out Holes, Tower, 2323K	17	82-6297	Sliding Bin Lid Kit
07	07-0556	Hole Plug, 1/2" Dia, SS	18	82-6216	Double Sliding Bin Lid, Cut Off
08	12-0097	Key Lock Switch, Maintain, Spade	19	82-3029	Power Supply Assembly, 120-24 V, 75 W, EX SW
09	30-5425-01	Splash Plate, 23" w/ Lancer Logo	-	07-0437	Oetiker Clamp, 7/16"
10	07-0405	Hole Plug, 3/4" Dia, SS	-	82-0992	Accessory Kit, 2323 ICDI
11	23-0862	Wire Drain Assembly, Ice Cooled	-	82-1600	Label Kit, 8 LEV, ICDI, 3-1-1-3
			-	08-0510	Drain Tube, CP, ICDI, Insulated

Plumbing Diagrams

2300, 6 Valve, Standard

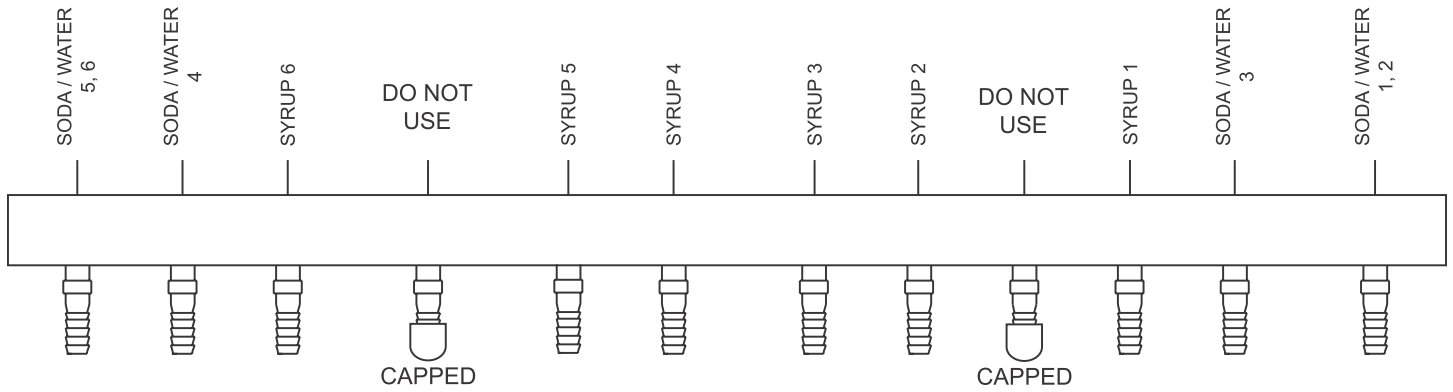

2300, 8 Valve, Standard

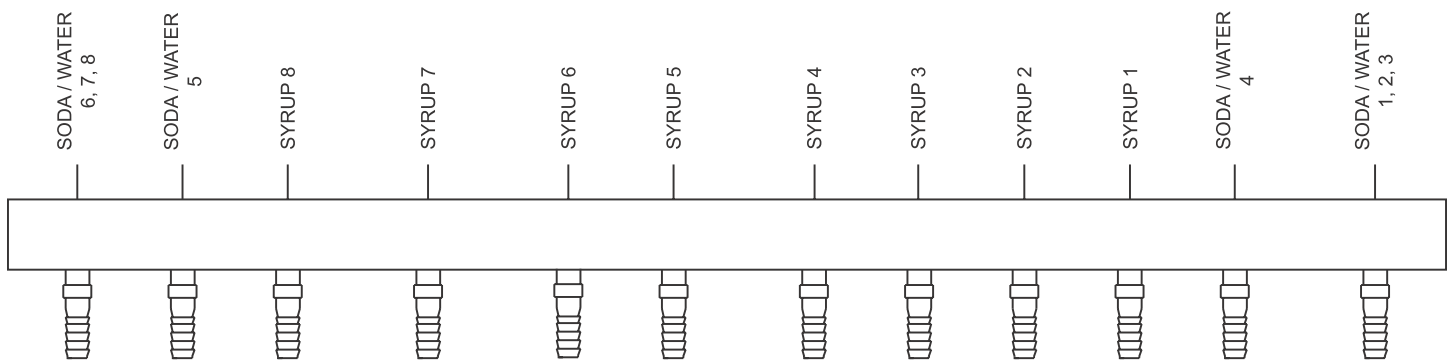

2300, 10 Valve, Standard

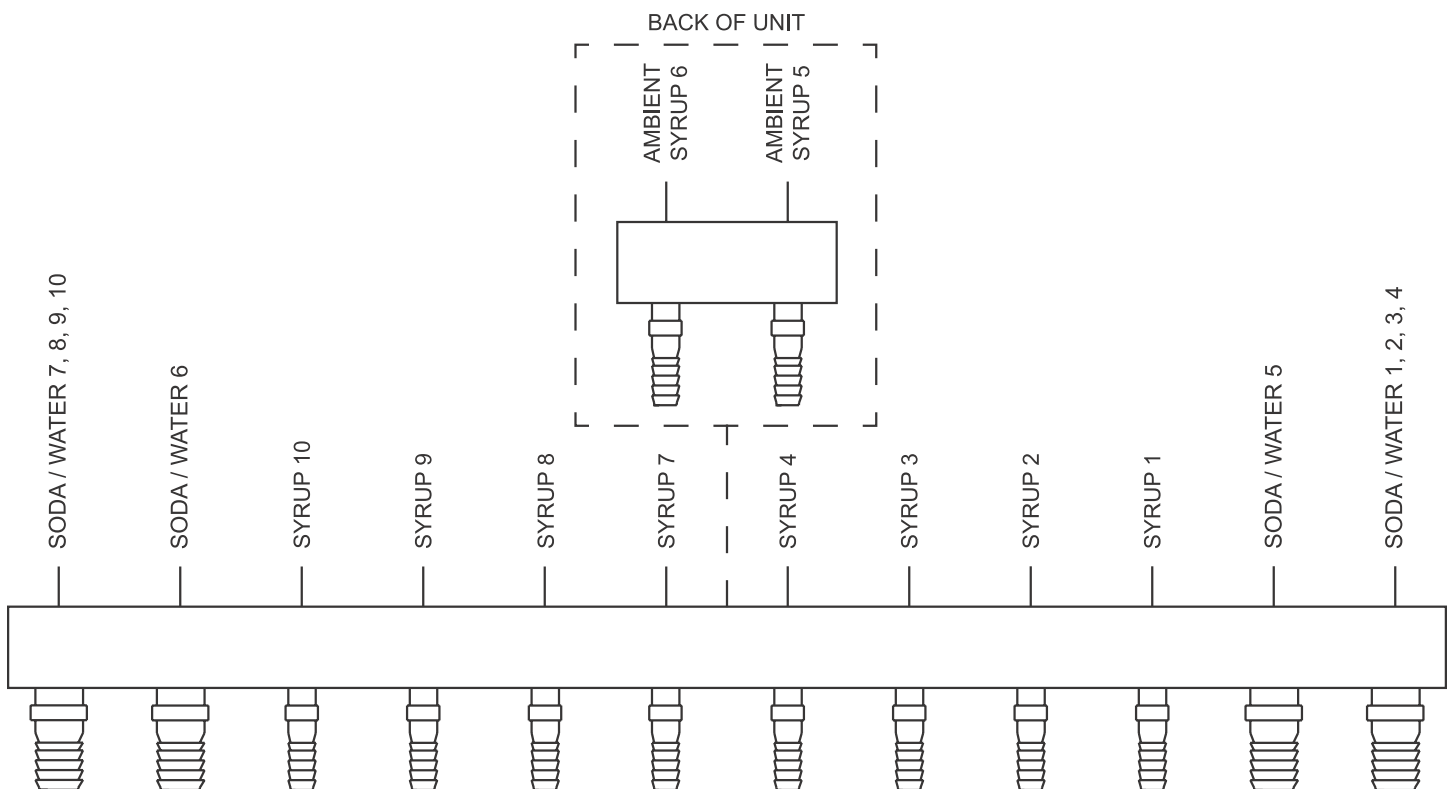

Tower Plumbing Diagrams

2300, 6 Valve, Standard

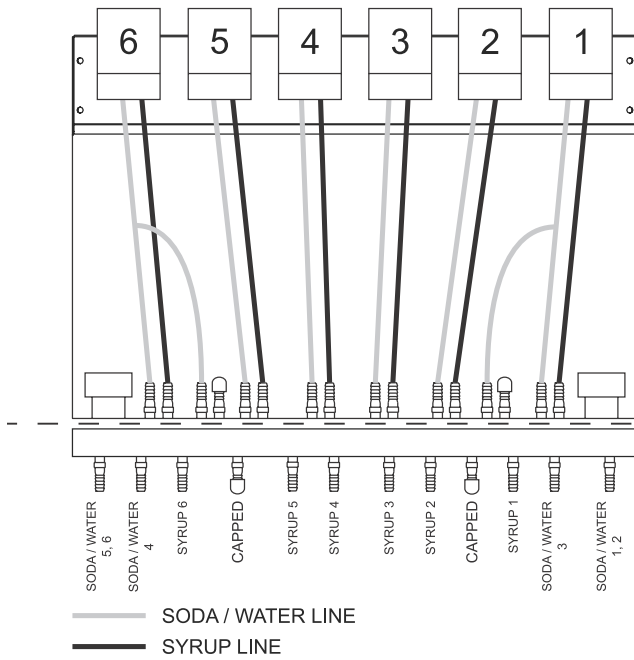

2300, 8 Valve, Standard

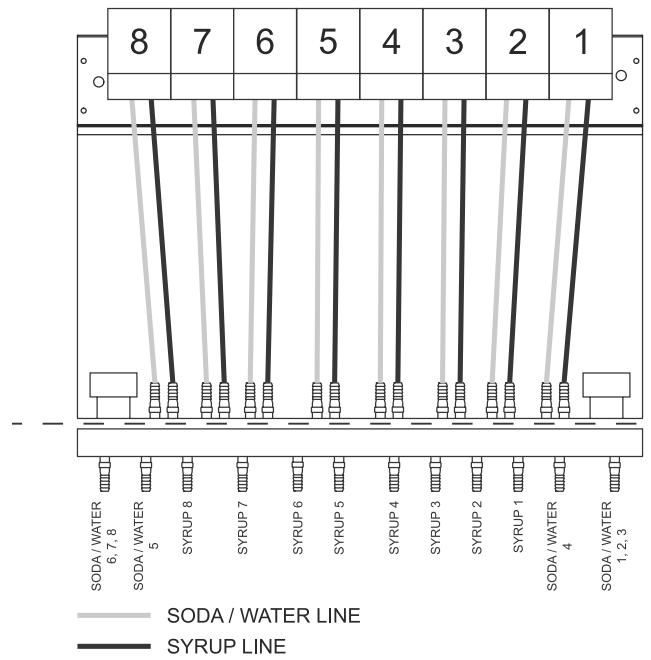

Wiring Diagram

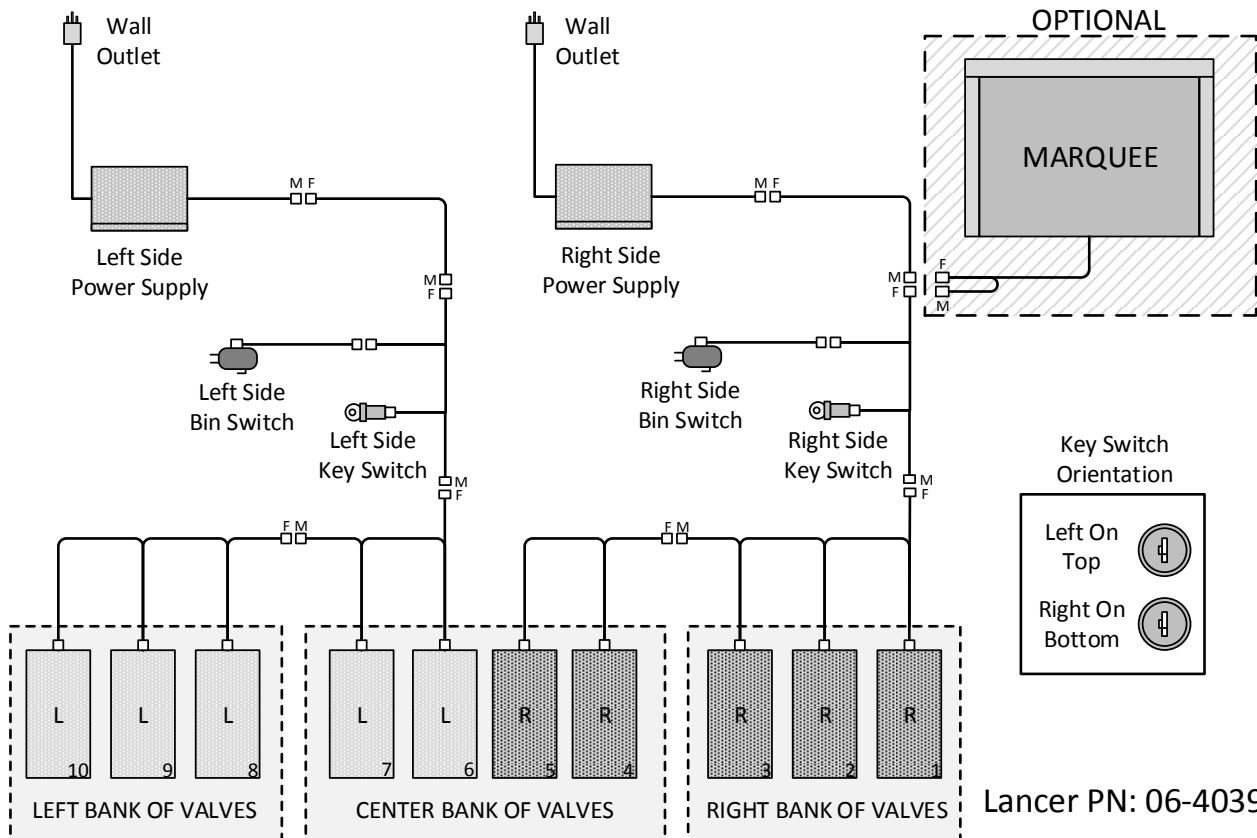

Counter Cut-Out Diagram

2300 Cut-Out

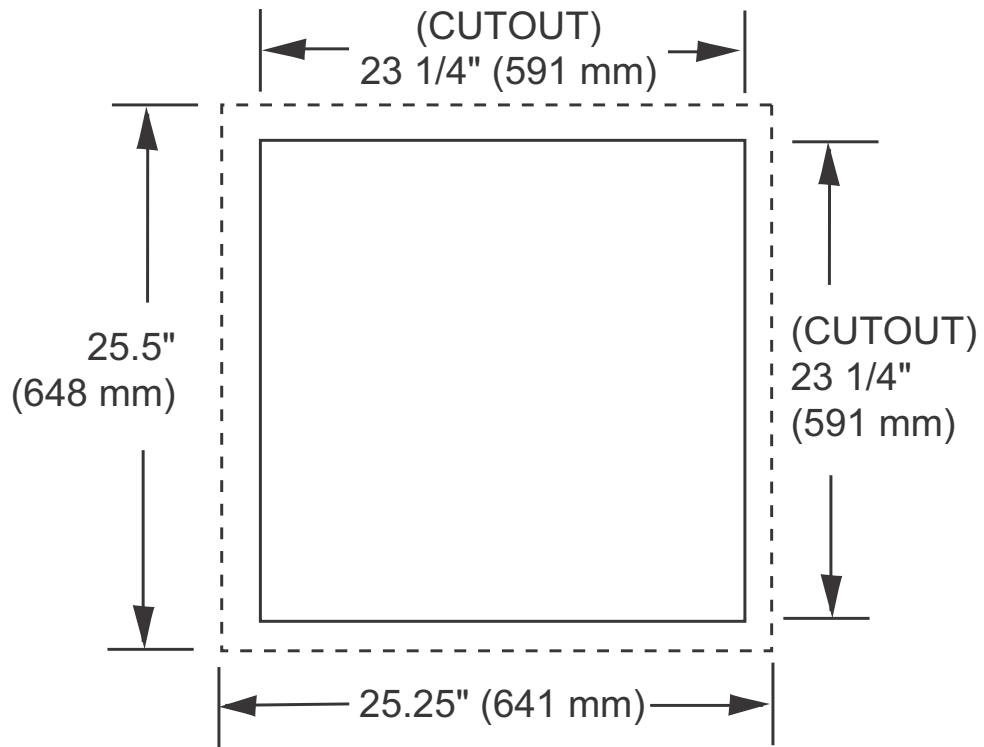

LANCER[®]

Lancer Corp.
800-729-1500
Technical Support/Warranty: 800-729-1550
custserv@lancercorp.com
lancercorp.com