

LANCER®

Flavor Select (FS) 30 Ice Beverage Dispenser



Operation Manual

Lancer Corporation
6655 Lancer Blvd.
San Antonio, Texas 78219
800-729-1500



Tech Support/Warranty: 800-729-1550

email: custserv@lancercorp.com

web: lancercorp.com

Lancer PN: 28-0558/07

Revision: March 2018

"Lancer" is the registered trademark of Lancer © 2018 by Lancer, all rights reserved.

TABLE OF CONTENTS

ABOUT THIS MANUAL

This booklet is an integral and essential part of the product. Please carefully read the guidelines and warnings contained herein as they are intended to provide the user with essential information for the continued safe use and maintenance of the product. In addition, it provides ***GUIDANCE ONLY*** to the user on the correct services and site location of the unit.

The installation and relocation, if necessary, of this product must be carried out by qualified personnel with up-to-date safety and hygiene knowledge and practical experience, in accordance with current regulations.

IMPORTANT SAFETY INSTRUCTIONS.....	3-4
Intended Use.....	3
Power Warning.....	3
CO ₂ Warning.....	3
Water Notice.....	3
Automatic Agitation.....	4
SPECIFICATIONS AND FEATURES.....	4-5
Flavor Select (FS) 30".....	4
General Systems Overview.....	5
Pre-Installation Checklist.....	5
INSTALLATION.....	6-12
Unpacking the Dispenser.....	6
Inspection of Drain Spider.....	6
Selecting/Preparing a Counter Location.....	7
Installing an Icemaker.....	7
Dispenser Installation.....	8
Remote Pump Installation.....	9
Installing Remote Syrup Pumps - Bag in Box.....	9
Installing CO ₂ Supply.....	10
Dispenser Setup.....	11
Adjust Water Flow Rate & Syrup/Water Ratio.....	12

BEFORE GETTING STARTED

Each unit is tested under operating conditions and is thoroughly inspected before shipment. At the time of shipment, the carrier accepts responsibility for the unit. Upon receiving the unit, carefully inspect the carton for visible damage. If damage exists, have the carrier note the damage on the freight bill and file a claim with carrier. Responsibility for damage to the dispenser lies with the carrier.

CLEANING AND SANITIZING.....	13-15
General Information.....	13
Cleaning and Sanitizing Solutions.....	13
Daily Cleaning.....	14
Ice Bin Cleaning - Start-Up and Monthly.....	14
Cleaning and Sanitizing Syrup Lines-Bag in Box.....	15
Ice Chute Cleaning.....	15
OPERATION AND MAINTENANCE.....	16-18
Programming and Setup Software.....	16
Menus and Sub-menus.....	17
Purging the Carbonation System.....	17
Carbonator Pump Modifications.....	18
TROUBLESHOOTING.....	18-21
Valve/Flavor Shot Troubleshooting.....	18-20
Ice Bin/Ice Chute/Carbonator Pump Troubleshooting.....	20-21
Remote Syrup/Flavor Shot Pump Troubleshooting.....	21
ILLUSTRATIONS AND PART LISTINGS.....	22-28
Main Unit Assembly.....	22-23
Ice Chute Assembly.....	24
Pellet Ice Bin Assembly.....	25
Lancer Flow Control Valve (LFCV).....	26
Wiring Diagram.....	27
Plumbing Diagram.....	27
Counter Cutout.....	28
DISPENSER DISPOSAL.....	29

READ ALL SAFETY INSTRUCTIONS BEFORE USING THIS UNIT.

This manual contains important safety information and all applicable safety precautions must be observed. To reduce the risk of fire, electric shock, damage to the equipment or personal injury when using this unit all instructions/warnings on the product being used must be followed:

WARNING

Text following the Warning signal indicates a hazardous situation, which if not avoided, will result in death or serious injury. Be sure to read all Warning statements before proceeding with the installation.

CAUTION

Text following the Caution signal indicates a hazardous situation, which if not avoided, could result in death or serious injury. Be sure to read the Caution statements before proceeding with the installation

ATTENTION

Text following the Attention signal addresses a situation that if not followed could potentially damage the equipment. Be sure to read the Attention statements before proceeding

NOTE

Text following the Note signal provides you with information that may help you more effectively perform the installation procedures within this manual. Disregarding information will not cause damage or injury, however it may limit the performance of the dispenser.

IMPORTANT SAFETY INSTRUCTIONS

Intended Use

- The dispenser is for indoor use only
- This appliance is intended to be used in commercial applications such as restaurants or similar.
- This appliance should not be used by children or infirm persons without supervision.
- This appliance is not intended for use by persons (including children) with reduced physical, sensory or mental capabilities, or lack of experience and knowledge, unless they have been given supervision or instruction concerning use of the appliance by a person responsible for their safety.
- This appliance can be used by children aged from 8 years and above and persons with reduced physical, sensory or mental capabilities or lack of experience and knowledge if they have been given supervision or instruction concerning use of the appliance in a safe way and understand the hazards involved.
- Cleaning and user maintenance shall not be performed by children without supervision.
- This unit is not a toy and children should be advised not to play with the appliance.
- The min/max ambient operating temperature for the dispenser is 40°F to 90°F (4°C to 32°C).
- Do not operate unit below minimum ambient operation conditions.
- Should freezing occur, cease operation of the unit and contact authorized service technician.
- The maximum tilt for safe operation is 5°.
- This appliance must be installed and serviced by a professional.

Carbon Dioxide (CO₂)

- **WARNING:** Carbon Dioxide (CO₂) is a colorless, noncombustible gas with a light pungent odor. High percentages of CO₂ may displace oxygen in the blood.
- **WARNING:** Prolonged exposure to CO₂ can be harmful. Personnel exposed to high concentrations of CO₂ gas will experience tremors which are followed by a loss of consciousness and suffocation.
- **WARNING:** If a CO₂ gas leak is suspected, immediately ventilate the contaminated area before attempting to repair the leak.
- **WARNING:** Strict attention must be observed in the prevention of CO₂ gas leaks in the entire CO₂ and soft drink system.

Power

- Follow all local electrical codes when making connections.
- Check the dispenser name plate label, located behind the splash plate, for the correct electrical requirements of unit. **DO NOT** plug into a wall electrical outlet unless the current shown on the serial number plate agrees with local current available.
- Each dispenser must have a separate electrical circuit.
- **DO NOT** use extension cords with this unit.
- **DO NOT** 'gang' together with other electrical devices on the same outlet.
- **WARNING:** Always disconnect electrical power to the unit to prevent personal injury before attempting any internal maintenance.
- The resettable breaker switch should not be used as a substitute for unplugging the dispenser from the power source to service the unit.
- Only qualified personnel should service internal components of electrical control housing.
- **WARNING:** Make sure that all water lines are tight and units are dry before making any electrical connections
- If this dispenser is installed in an area that is susceptible to ±10% variation of the nominal line voltage, consider installing a surge protector or similar protection device.

Water Notice

- Provide an adequate, potable water supply. Water pipe connections and fixtures directly connected to a potable water supply must be sized, installed, and maintained according to federal, state, and local codes.
- The water supply line must be at least a 3/8 inches (9.525 mm) pipe with a minimum of 25 PSI (0.172 MPA) line pressure, but not exceeding a maximum of 125 PSI (0.860 MPA). Water pressure exceeding 125 PSI (0.860 MPA) must be reduced to 125 PSI (0.860 MPA).
- Use a filter in the water line to avoid equipment damage and beverage off-taste. Check the water filter periodically, as required by local conditions.
- **CAUTION:** The water supply must be protected by means of an air gap, a backflow prevention device (located upstream of the CO₂ injection system) or another approved method to comply with NSF standards. A leaking inlet water check valve will allow carbonated water to flow back through the pump when it is shut off and contaminate the water supply.
- **CAUTION:** Ensure the backflow prevention device complies with ASSE and local standards. It is the responsibility of the installer to ensure compliance.

⚠ Automatic Agitation

- Units are equipped with an automatic agitation system and will activate unexpectedly.
- **CAUTION:** Do not place hands or foreign objects in the ice bin tank. Unplug the dispenser during servicing, cleaning, and sanitizing.
- **CAUTION:** To avoid personal injury, do not attempt to lift the dispenser without assistance. For heavier dispensers, use a mechanical lift.

SPECIFICATIONS AND FEATURES

Flavor Select (FS) 30"

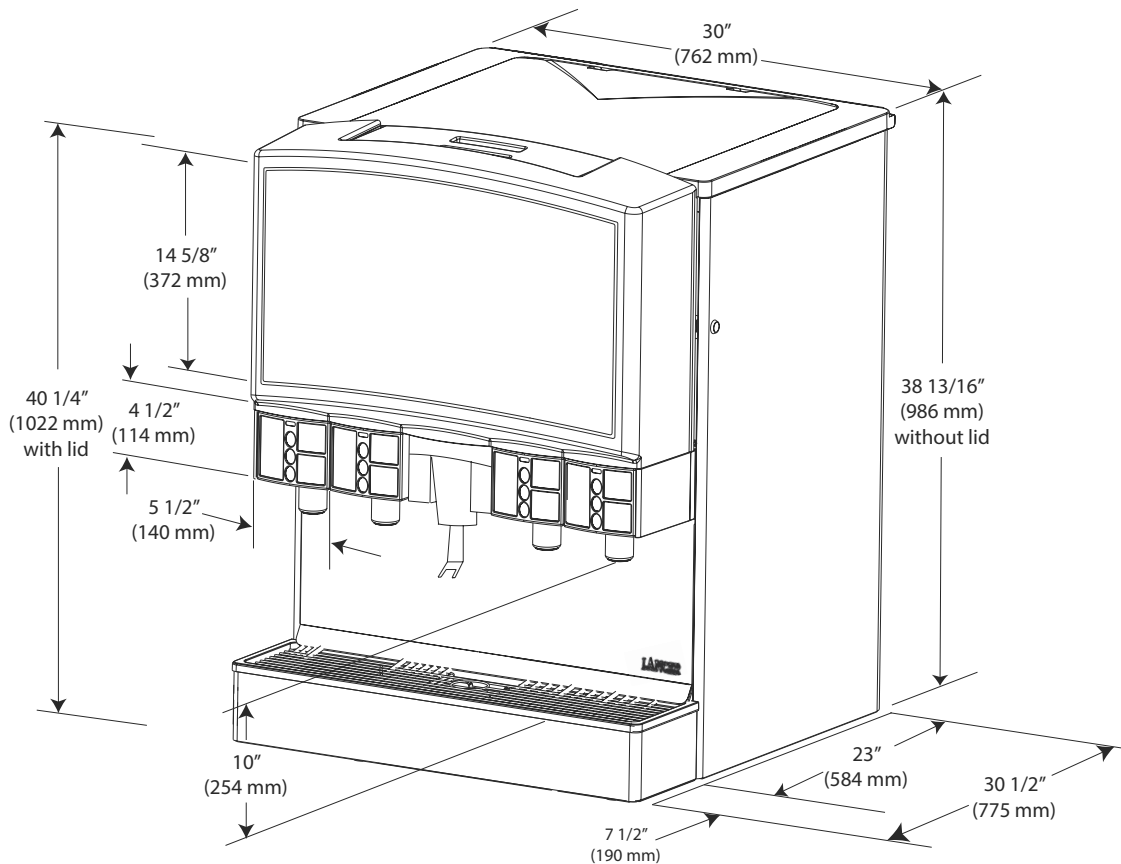

DIMENSIONS

Width: 30 inches (762 mm)
Depth: 30.5 inches (775 mm)
Height: 40.25 inches (1022 mm)

WEIGHT

Shipping: 356 lbs (161 kg)
Empty (without Ice): 320 lbs (145 kg)
Full (with Ice): 620 lbs (281 kg)
Ice Capacity: 290 lbs (132 kg)
Ice Dispensable: 215 lbs (98 kg)

ELECTRICAL

115 VAC / 60 Hz / 7.0 Amps

PLAIN WATER SUPPLY

Min Flowing Pressure: 75 PSIG
(0.516 MPA)

CARBONATED WATER SUPPLY

Min Flowing Pressure: 25 PSI
(0.172 MPA)
Max Static Pressure: 50 PSI
(0.345 MPA)

CARBON DIOXIDE (CO₂) SUPPLY

Min Pressure: 70 PSIG (0.483 MPA)
Max Pressure: 80 PSIG (0.552 MPA)

FITTINGS

Carbonator Inlet: 3/8 in barb
Plain Water Inlet: 3/8 in barb
Brand Syrup Inlets: 3/8 in barb
Flavor Injector Inlets: 1/4 in barb
CO₂ Inlet: 3/8 in barb

General System Overview

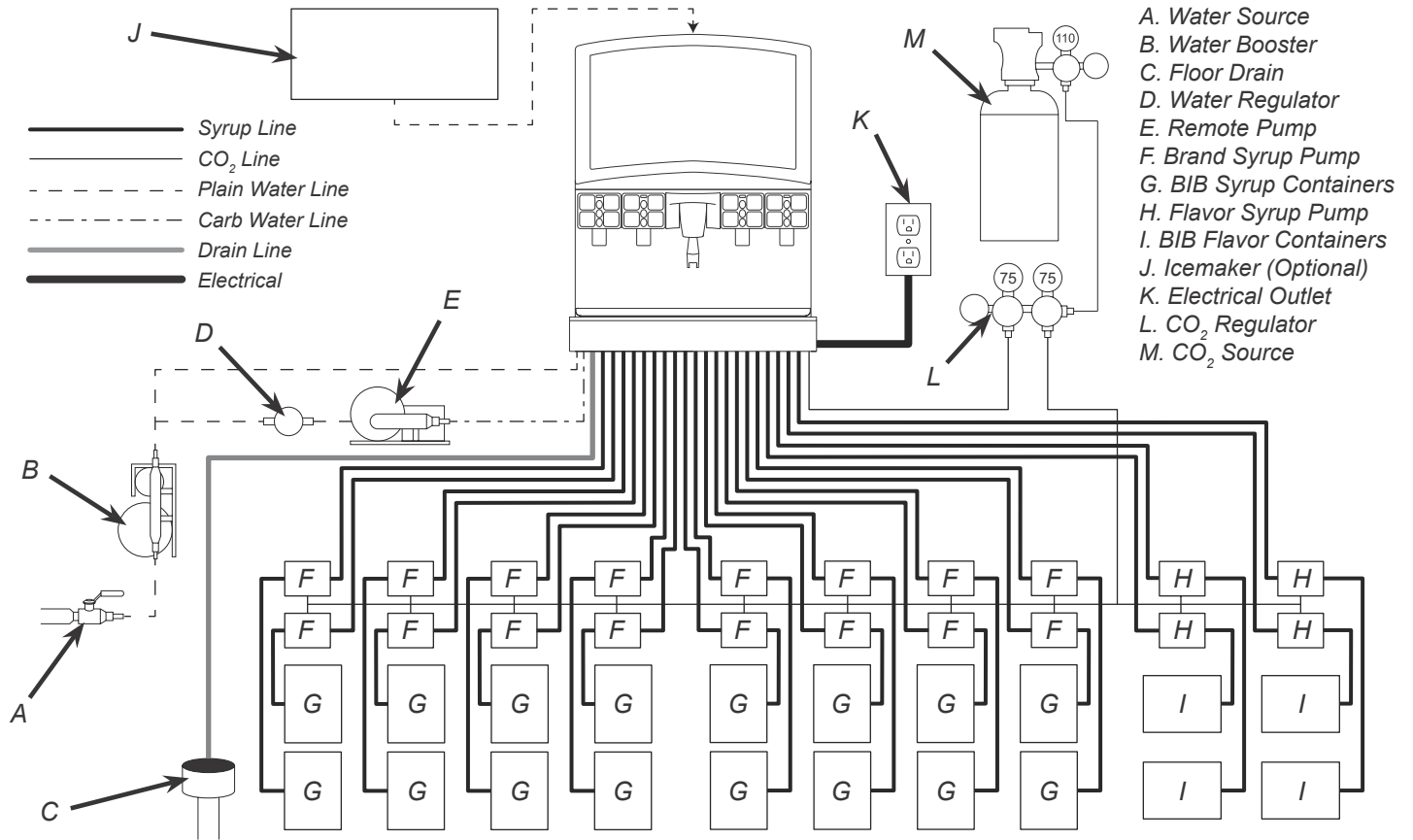

Pre-Installation Checklist

TOOLS REQUIRED:

- Oetiker Pliers
- Tubing Cutters
- Wrench
- Slotted Screwdriver
- Phillips Screwdriver
- Drill

BIB SYSTEM:

- BIB Rack
- BIB Syrup Boxes
- BIB Regulator Set
- BIB Connectors

POST MIX ACCESSORIES:

- High Pressure CO₂ Regulator
- Low Pressure CO₂ Regulator Manifold
- CO₂ Supply
- Chain for CO₂ Tank
- Beverage Dispenser
- Beverage Tubing
- Oetiker Clamp Fittings
- Water Booster (Lancer PN: 82-3401 or MC-163172)
- Water Regulator (supplied with unit)

CONSIDER THE FOLLOWING BEFORE INSTALLATION:

- Location of Water Supply Lines
- Location of Drain
- Location of Electrical Outlet
- Location of Heating and Air Conditioning Ducts
- Do you have enough space to install the dispenser?
- Is countertop level?
- Can the countertop support the weight of the dispenser? (Include the weight of an ice machine plus weight of ice, if necessary)
- Is dispenser located away from direct sunlight or overhead lighting?

INSTALLATION

Read This Manual

This manual was developed by Lancer Corporation as a reference guide for the owner/operator and installer of this dispenser. Please read this manual before installation and operation of this dispenser. See pages 20 - 23 for troubleshooting or service assistance. If the service cannot be corrected please call your Service Agent or Lancer Customer Service. Always have your model and serial number available when you call.

Unpacking the Dispenser

1. Set shipping carton upright on the floor then cut package banding straps and remove.
2. Open top of carton and remove interior packaging.
3. Lift carton up and off of the unit.
4. Remove plywood shipping base from unit by moving unit so that one side is off the counter top or table allowing access to screws on the bottom of the plywood shipping base.

NOTE

If unit is to be transported, it is advisable to leave the unit secured to the plywood shipping base.

5. Remove accessory kit and loose parts from ice compartment.

NOTE

Inspect unit for concealed damage. If evident, notify delivering carrier and file a claim against the same.

6. If leg kit has been provided, assemble legs by tilting unit.

⚠ ATTENTION

DO NOT LAY UNIT ON ITS SIDE OR BACK

Inspection of Drain Spider

NOTE

The drain spider is located directly in the center of the bin under the ice shroud. The coldplate has a cavity designed to hold the drain spider. During shipment or installation, the drain spider may become dislodged from its original position. Prior to installing the dispenser, ensure the drain spider is in the correct position. This will prevent drain clog issues. Inspect the lower bin area and reach under the shroud to ensure the drain spider is secure in the coldplate cutout. If the drain spider is not in place, proceed with the following steps:

1. Remove agitator clip and pin from agitator bar.
2. Remove agitator bar from paddle wheel (see figure below, right side).
3. Remove paddle wheel.
4. Remove ice shroud by lifting back then out of bin.
5. Locate drain spider and reinstall in the coldplate cavity where drain line exits (see figure below, left side).
6. Reinstall all components. Ensure agitator clip is locked.

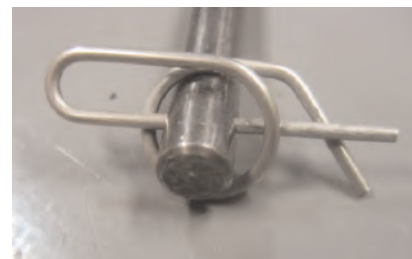
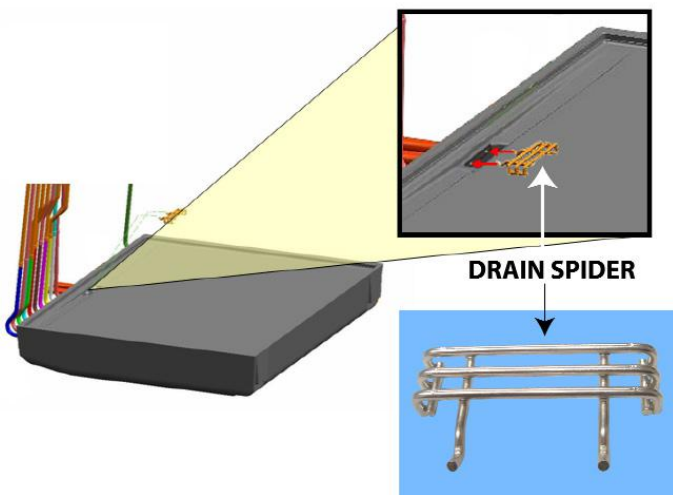

Selecting/Preparing a Counter Location

NOTE

The dispenser should only be installed in a location where it can be overseen by trained personnel

1. Select a level, well ventilated location that is in close proximity to a properly grounded electrical outlet, within five (5) feet (1.5 m) of a drain, a water supply that meets the requirements shown in the Specifications section found on pages 4-6, away from direct sunlight or overhead lighting, and has sufficient clearance for air circulation.
2. Sufficient clearance must be provided, if an ice maker is not installed, to allow filling ice compartment from a five gallon bucket (a minimum of 16 inches is recommended).

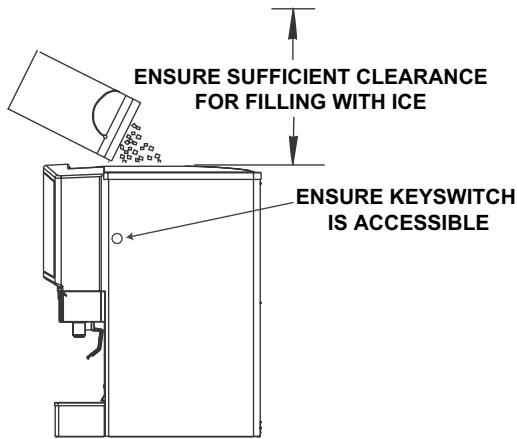

NOTE

Fill unit with ice only with merchandiser intact.

3. The selected location should be able to support the weight of the dispenser, ice and possibly an icemaker being installed after counter cut out is made. Total weight (with icemaker) for this unit could exceed 800 pounds (363.6kg).

NOTE

Lancer does **NOT** recommend the use of shaved or flake ice in the dispenser.

4. Unit may be installed directly on countertop or on legs. If installed directly on the counter, unit must be sealed to the countertop with an FDA approved sealant. If an icemaker is to be mounted on top of dispenser, do not install dispenser on legs.
5. Select a location for the remote pump deck, remote syrup pumps, remote flavor shot syrup pumps (if necessary), CO₂ tank, syrup containers, and water filter (recommended). Please see General System Overview on page 5 for reference.
6. Using Counter Cutout Template provided, cut out required opening for the water, syrup, and CO₂ lines in the designated dispenser location.

Leveling the Dispenser:

In order to facilitate proper dispenser drainage, ensure that the dispenser is level, front to back and side to side. Place a level on the top of the rear edge of the dispenser. The bubble must settle between the level lines. Repeat this procedure for the remaining three sides. Level unit if necessary. For optimum performance place the unit at a 0° tilt. The maximum tilt is 5°.

Installing an Icemaker (if necessary)

⚠ ATTENTION

When installing an icemaker on the dispenser, use a bin thermostat to control the ice level (see below). This will prevent damage to the dispensing mechanism. The bracket for mounting a thermostat is located in the ice bin. During the automatic agitation cycle and while dispensing ice, ensure there is adequate space between the top of the ice level and the bottom of the icemaker so the ice can move without obstruction. Contact your icemaker manufacturer for information on a suitable bin thermostat.

1. Install the icemaker per manufacturer specifications. Points of consideration include drainage, ventilation, and drop zones.
2. An adapter plate is required when installing an icemaker. Contact your Sales Representative or Lancer Customer Service for more information.
3. A bin thermostat is required in order to control the level of ice in the dispenser (Refer to ATTENTION). Contact your icemaker manufacturer to obtain the correct bin thermostat.

4. Bin thermostat should be a minimum of 2" below the top edge of the dispenser. The preferred location of the bin thermostat is on the left side wall.

⚠ ATTENTION

Failure to use an ice bin thermostat will not only void your IBD's warranty but will result in the inability to control the level of ice in the ice bin which can cause damage to your dispenser.

5. Ensure the icemaker is installed properly to allow for removal of the Merchandiser.
6. Ensure manual fill is accessible.
7. Clean and maintain icemaker per manufacturer's instructions.

Attach Bin Stat Bracket As Shown

Recommended Bin Stat Attachment

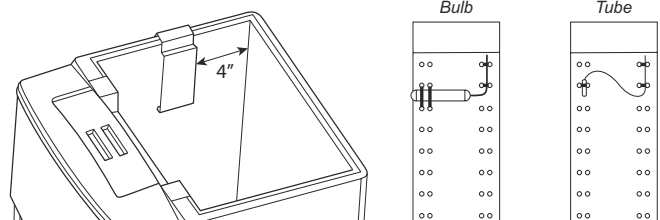

Dispenser Installation

1. Remove the cup rest, drip tray, splash plate, merchandiser, and top cover from the unit.
2. Remove the cover plate at the back of the unit (if not a through-the-counter installation).
3. Route appropriate tubing from the plain water supply line and the water supply for the carbonator and connect tubing to 3/8 inch barb inlets at the front of the unit using the oetiker pliers and fittings.

NOTE

See Plumbing Diagrams on the front of the unit or on pages 26 - 27 for reference.

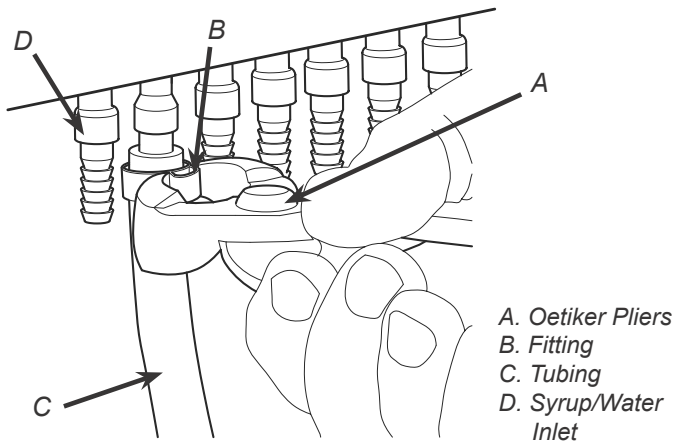

4. Connect tubing to water source then flush water lines to check for leaks.
5. Route appropriate tubing from the remote pump deck to the carbonated water inlet and connect tubing to inlet.
6. Route appropriate tubing from the syrup pump location to the syrup inlets at front of the unit and connect tubing to inlets.
7. Repeat Step 5 for flavor injector lines.
8. Route appropriate tubing from the CO₂ source location to the CO₂ inlet on the unit and connect tubing to inlet.

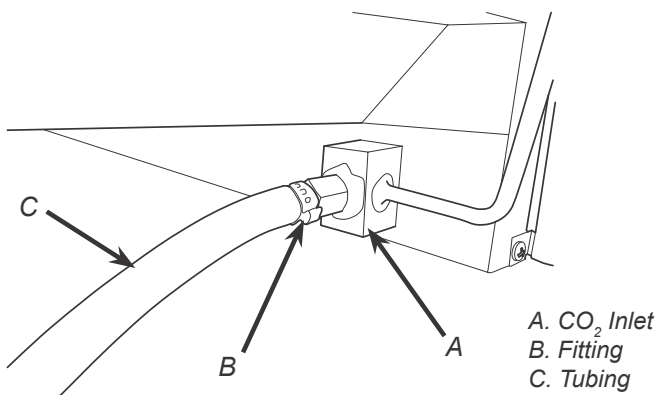

9. Route drain hose from designated open type drain to fitting on Drip Tray and connect hose to fitting.

CAUTION

Drain line must be insulated with a closed cell insulation. Insulation must cover the entire length of the drain hose, including fittings. The drain should be installed in such a manner that water does not collect in sags or other low points, as condensation will form.

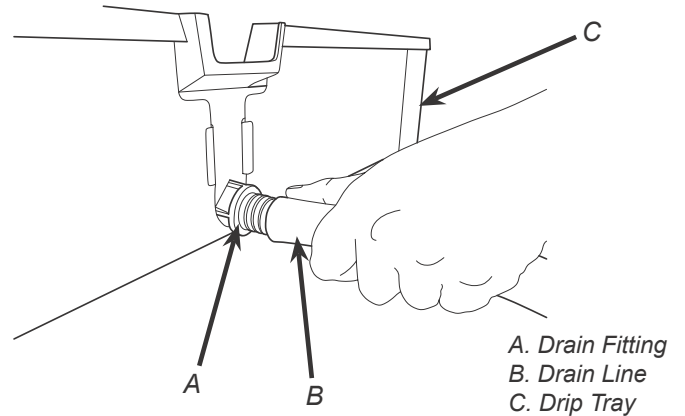

ATTENTION

Pouring hot water into drain may cause the Drain Tube to collapse. Allow only luke warm or cold water to enter Drain Tube. Pouring coffee tea and similar substances into drain may cause the Drain Tube to become clogged with coffee or tea grounds, or other solid particles.

10. Reattach Drip Tray/Cup Rest to unit.
11. Route the power supply cord to a grounded electrical outlet of the proper voltage and amperage rating.

WARNING

DO NOT PLUG UNIT INTO GROUNDED ELECTRICAL OUTLET AT THIS TIME. Make sure that all water lines are tight and unit is dry before making any electrical connections

Remote Pump Installation

1. If necessary, install water booster (Lancer PN MC-163172) between water supply and the unit.
2. Using tubing cutters, cut water line and install tee fitting, then route appropriate tubing from the remote pump location to the tee fitting at water line.
3. Connect line from tee fitting at water line to the remote pump deck inlet regulator.

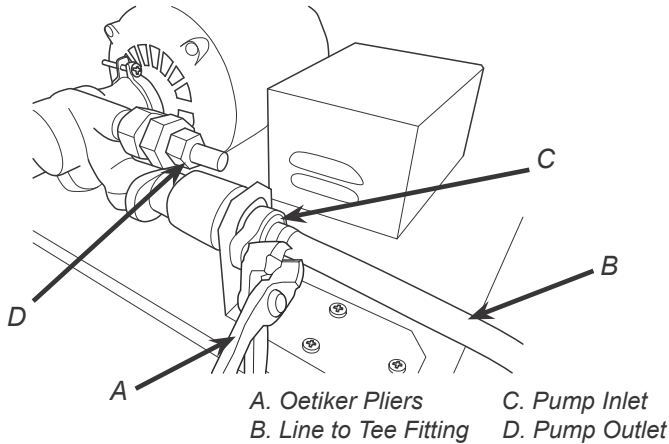

4. Complete the carbonated water line connection, installed in the previous section, between the remote pump deck and carbonated water inlet on the unit.

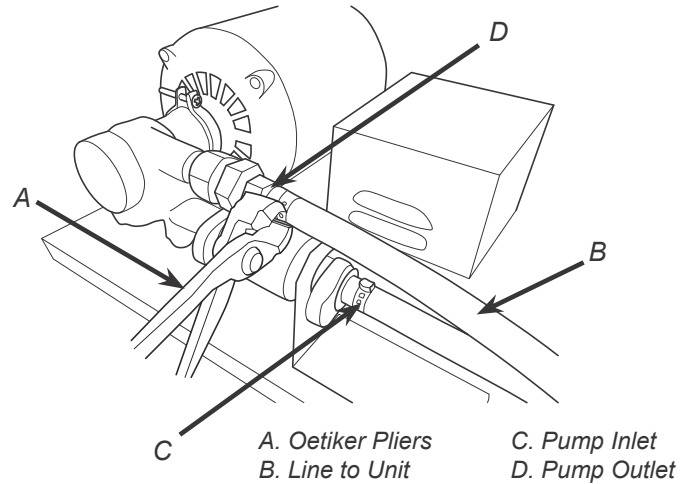

5. Install a shut-off valve in the water line feeding the deck. If a separate water line is run for plain water, ensure that it also has a shut-off valve.

Installing Remote Syrup Pumps - Bag In Box

1. Install BIB rack and remote pumps according to manufacturers' instructions.
2. Once pumps and BIB rack are installed, measure and cut tubing to length between the pump CO₂ inlets, then connect tubing to all pumps.

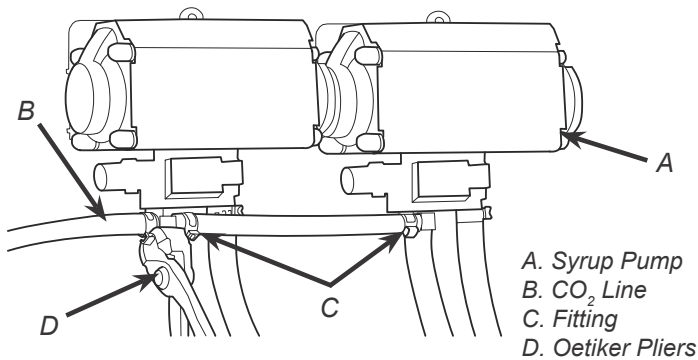

3. Using tubing cutters, cut any pump CO₂ supply line and install tee fitting, then route appropriate tubing from the CO₂ supply to the tee fitting at syrup pumps.

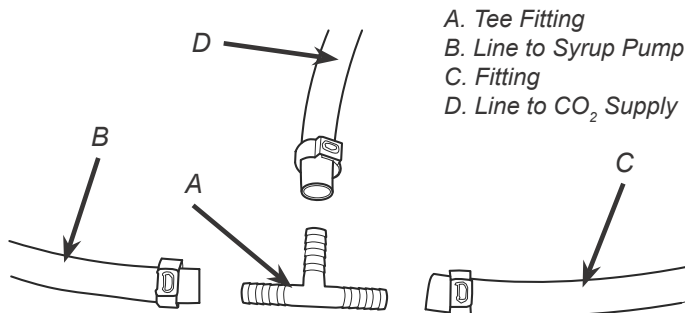

4. Connect tubing from dispenser syrup inlet to the syrup pump outlet fitting. Repeat for each syrup line and flavor injector line.

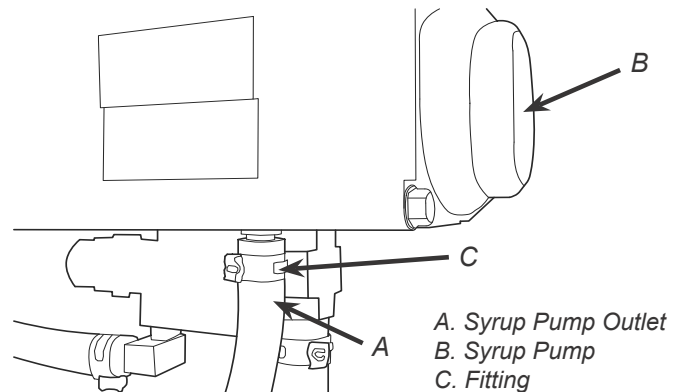

5. Install BIB (bag in box) connectors onto the syrup pump inlet tubing.

⚠ ATTENTION
Use proper connector for syrup manufacturer

6. Connect syrup BIBs to connectors. Repeat for each syrup line/pump and each flavor shot line/pump.

Installing CO₂ Supply

1. Connect high pressure CO₂ regulator assembly to CO₂ cylinder or bulk system.

⚠ ATTENTION

Before installing regulator, assure that a seal (washer or o-ring) is present in regulator attachment nut.

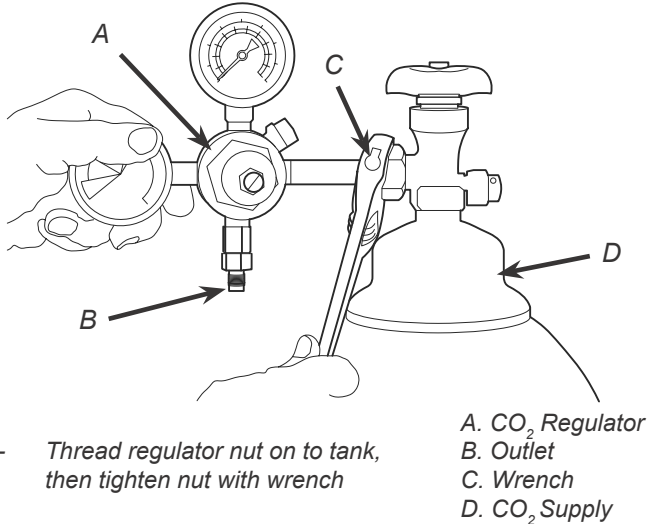

2. Connect a 1/4" nut, stem and seal to CO₂ regulator outlet.

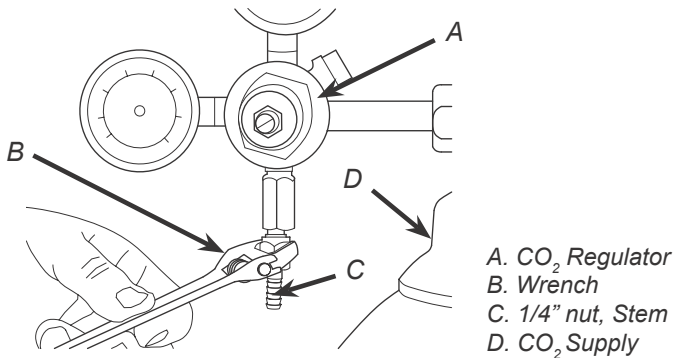

3. Route appropriate tubing from the low pressure CO₂ regulator manifold location to the 1/4" nut, stem on the high pressure CO₂ regulator attached to source and connect tubing.

⚠ ATTENTION

A dedicated CO₂ regulator is required to supply the CO₂ inlet at the unit as well as to all syrup pumps.

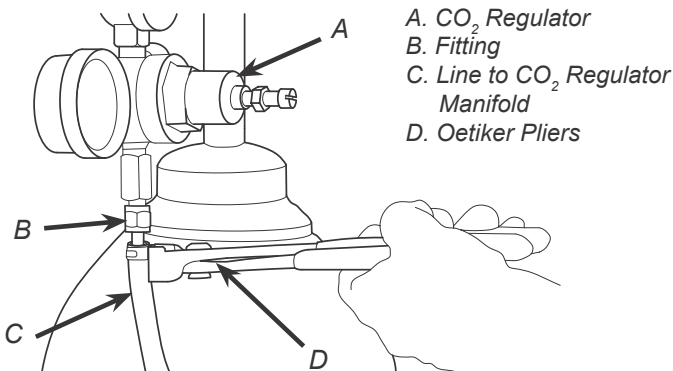

4. Connect tubing routed from the CO₂ inlet at the unit to one of the low pressure CO₂ regulator manifold outlets.
5. Connect tubing routed from the tee at the syrup pumps to the second outlet of the low pressure CO₂ regulator manifold.

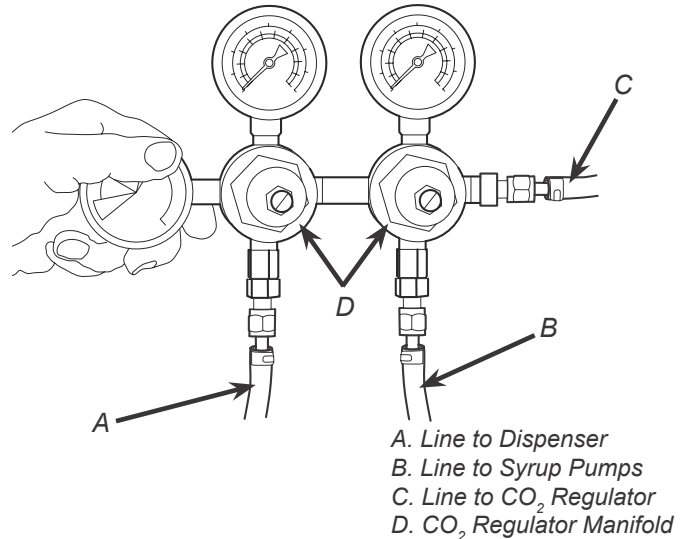

6. Using a wrench, loosen lock nut on the regulator adjustment screw of the high pressure CO₂ regulator connected to the source, then using a screwdriver back out lock nut screw all the way.

⚠ WARNING

DO NOT TURN ON CO₂ SUPPLY AT THIS TIME

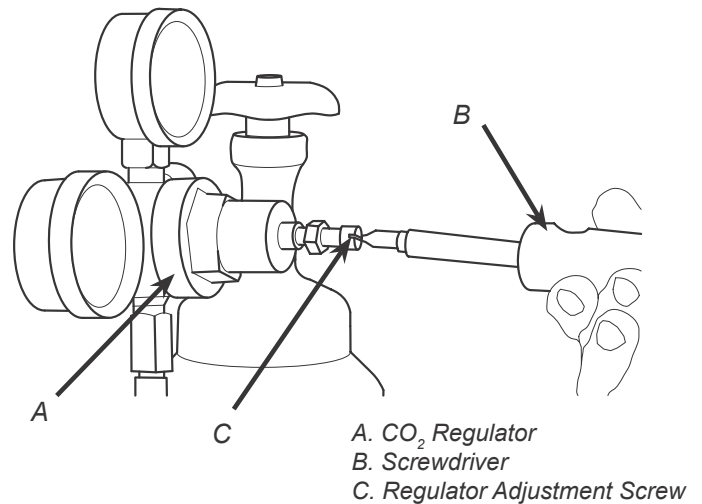

7. Repeat Step 6 for both low pressure CO₂ regulators on the regulator manifold routed to the unit and the syrup pumps.

Dispenser Setup

1. Turn on water source.
2. Open the pressure relief valve located on the front of the unit, by flipping up on the valve cap lever. Hold open until water flows from the relief valve then close (flip down) the relief valve.

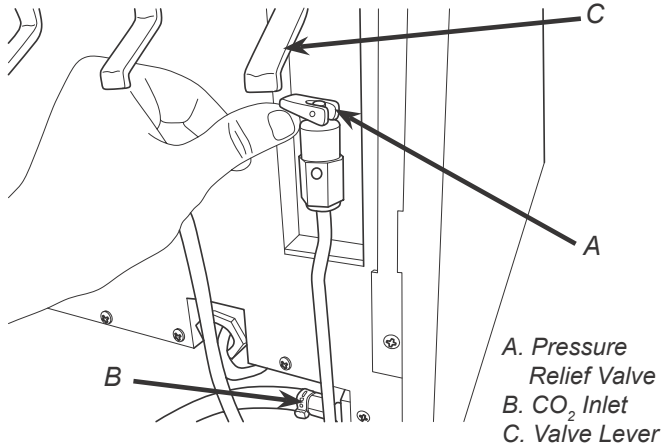

3. Verify all Bag-In-Box contains syrup and check all connections for leaks.
4. Place enough ice in the ice bin to fill approximately 1/2 of the bin before plugging in the unit.
5. Connect unit power cord to grounded electrical outlet.

⚠ WARNING

The dispenser must be properly electrically grounded to avoid serious injury or fatal electrical shock. The power cord has a three-prong grounded plug. If a three-hole grounded electrical outlet is not available, use an approved method to ground the unit. Follow all local electrical codes when making connections. Each dispenser must have a separate electrical circuit. Do not use extension cords. Do not connect multiple electrical devices on the same outlet.

6. Test the motor operation by pushing the ice chute lever until agitator motor begins to turn.
7. Activate each valve to ensure a good flow of water is achieved.
8. Ensure pump deck is turned OFF before turning on CO₂.

9. Turn on CO₂ at the source then, using a screwdriver, adjust the high pressure regulator at the source to 110 PSI (0.758 MPA) then tighten locknut with wrench.

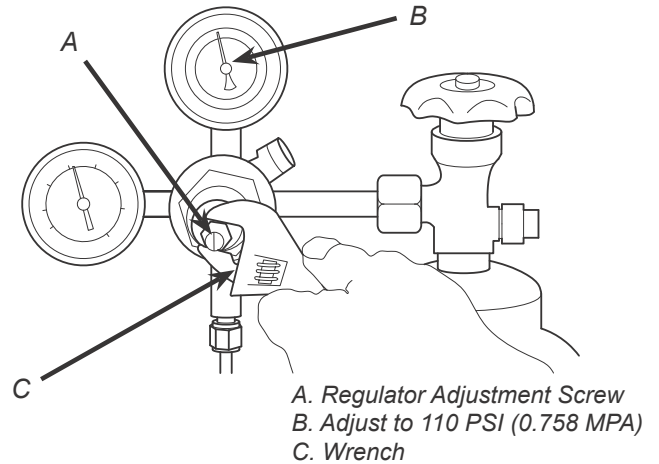

10. Adjust both of the low pressure regulators on the regulator manifold to 75 PSI (0.517 MPA) then tighten locknut with wrench.
11. Activate each valve until gas-out.
12. Plug in the remote carbonator pump deck, if not already done so, and turn the switch to the ON position.
13. Activate each valve until the carbonator pump comes on. Release the button, allow carbonator to fill and stop. Repeat this process until a steady flow of carbonated water is achieved.

NOTE

The pump deck has a 3 minute timeout feature. If the timeout occurs, turn the deck OFF then ON by flipping the switch on the control box.

NOTE

To check for CO₂ leaks, close the valve on the CO₂ cylinder and observe if the pressure to the system drops with the cylinder valve closed for five minutes. Open the cylinder valve after check.

14. Activate each valve to purge air from the syrup lines.

Adjust Water Flow Rate & Syrup/Water Ratio

NOTE

The water flow can be adjusted between 3.25 oz/sec (96 ml/sec) and 4.50 oz/sec (133 ml/sec) on all dispensing valves. Ensure there is ice on the cold plate and the lines are cold before attempting to set the flow rates on the valves. The drink temperature should be no higher than 40°F (4.4°C) when flow rates are set.

1. If necessary, rotate switches panel forward and down by releasing the two pin latches on its sides.
2. Rotate light panel, forward and up by releasing the two pin latches on its sides towards the top.
3. Using a Lancer ratio cup verify water flow rate. Use a screwdriver to adjust if needed.

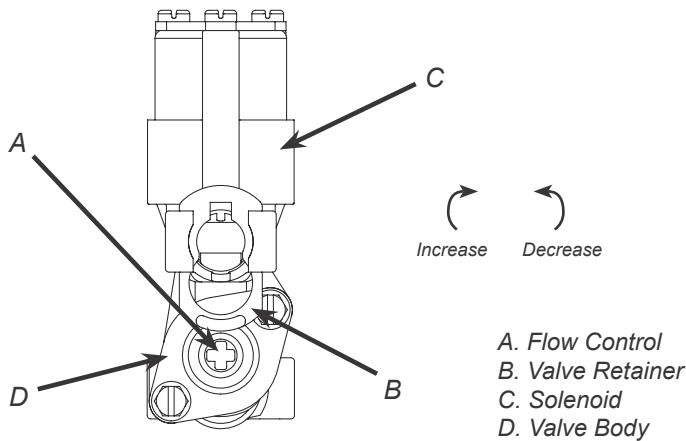

4. Repeat procedure for each water valve.

NOTE

There can be up to six gray water valves on this dispenser (up to four carbonated water valves and two plain water valves)

5. Remove nozzle by twisting counter clockwise and pulling down.
6. Install Lancer syrup separator (PN 82-3458) in place of nozzle.
7. Activate valve to purge syrup until steady flow is achieved.
8. Using a Lancer brix cup, activate the valve and capture a sample. Verify that the syrup level is even with the water level. Use a screwdriver to adjust if needed.

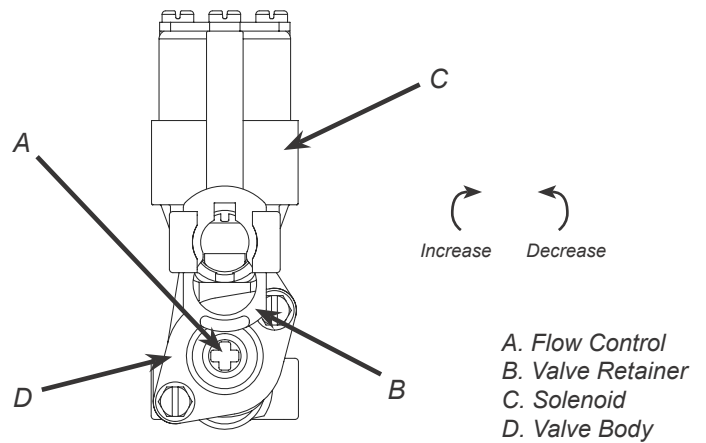

9. Remove syrup separator and reinstall nozzle.
10. Repeat Steps 5-9 for each syrup valve.
11. Re-install merchandiser and top cover.

CLEANING AND SANITIZING

General Information

- Lancer equipment (new or reconditioned) is shipped from the factory cleaned and sanitized in accordance with NSF guidelines. The operator of the equipment must provide continuous maintenance as required by this manual and/or state and local health department guidelines to ensure proper operation and sanitation requirements are maintained.

NOTE

The cleaning procedures provided herein pertain to the Lancer equipment identified by this manual. If other equipment is being cleaned, follow the guidelines established by the manufacturer for that equipment.

- Cleaning should be accomplished only by trained personnel. Sanitary gloves are to be used during cleaning operations. Applicable safety precautions must be observed. Instruction warnings on the product being used must be followed.

⚠ ATTENTION

- Use sanitary gloves when cleaning the unit and observe all applicable safety precautions.
- **DO NOT** use a water jet to clean or sanitize the unit.
- **DO NOT** disconnect water lines when cleaning and sanitizing syrup lines, to avoid contamination.
- **DO NOT** use strong bleaches or detergents; These can discolor and corrode various materials.
- **DO NOT** use metal scrapers, sharp objects, steel wool, scouring pads, abrasives, or solvents on the dispenser.
- **DO NOT** use hot water above 140° F (60° C). This can damage the dispenser.
- **DO NOT** spill sanitizing solution on any circuit boards. Insure all sanitizing solution is removed from the system.

Cleaning and Sanitizing Solutions

Cleaning Solution

Mix a mild, non-abrasive detergent (e.g. Sodium Laureth Sulfate, dish soap) with clean, potable water at a temperature of 90°F to 110°F (32°C to 43°C). The mixture ratio is one ounce of cleaner to two gallons of water. Prepare a minimum of five gallons of cleaning solution. Do not use abrasive cleaners or solvents because they can cause permanent damage to the unit. Ensure rinsing is thorough, using clean, potable water at a temperature of 90°F to 110°F. Extended lengths of product lines may require additional cleaning solution.

Sanitizing Solution

Prepare the sanitizing solution in accordance with the manufacturer's written recommendations and safety guidelines. The type and concentration of sanitizing agent recommended in the instructions by the manufacturer shall comply with 40 CFR §180.940. The solution must provide 100 parts per million (PPM) chlorine (e.g. Sodium Hypochlorite or bleach) and a minimum of five gallons of sanitizing solution should be prepared.

Other Supplies Needed:

1. Clean cloth towels
2. Bucket
3. Extra nozzle
4. Sanitary gloves
5. Small brush (PN 22-0017)

⚠ WARNING

If a powder sanitizer is used, dissolve it thoroughly with hot water prior to adding to the syrup system. Ensure sanitizing solution is removed from the dispenser as instructed. Avoid getting sanitizing solution on circuit boards. Do not use strong bleaches or detergents; these can discolor and corrode various materials. Do not use metal scrapers, sharp objects, steel wool, scouring pads, abrasives, or solvents on the dispenser. Do not use hot water above 140° F (60° C). This can damage the dispenser.

Daily Cleaning

1. Carefully remove the nozzle housings by turning counterclockwise and pulling down from the nozzle body.
2. Wash the nozzle housings in cleaning solution and rinse with clean warm water.
3. Wet a clean cloth in cleaning solution.
4. While the nozzle housing is removed, wipe down the perimeter and end of the nozzle body.
5. Fill a cup with clean warm water and rinse nozzle body.
6. Make certain that the nozzle o-ring is not torn or otherwise damaged. If necessary, replace damaged o-ring with Lancer PN 02-0231.
7. Wet the inner surface of the nozzle housing with water and reinstall the nozzle housing by sliding it over the nozzle body and turning clockwise to lock in position.

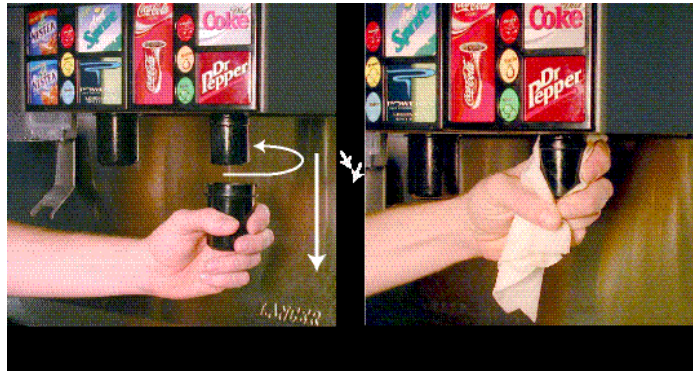

Ice Bin Cleaning - Start-Up and Monthly

NOTE

Refer to the Automatic Agitation Warning on page 4.

1. Disconnect power to the dispenser
2. Remove Top Cover.
3. Melt out any remaining ice from the bin.
4. Remove Agitator Pin from Agitator Shaft. Slide Agitator Shaft rearward out of the motor shaft and pull out of rear bearing to remove.
5. Remove the dispensing wheel from the motor shaft by sliding rearward.

NOTE

Steps 6-7 highlight how to remove a white pellet ice wheel shroud. If the unit uses a black cubed ice wheel shroud, skip to step 8.

6. Remove the gasket which secures the shroud by pulling it out, (See page XX for reference).
7. Push the front section of the wheel shroud back, then pull the shroud up and out to remove.
8. Remove the dispensing wheel shroud assembly.

9. Remove the lower ice chute assembly.
10. Use the Cleaning Solution, and a clean cloth or soft brush, to clean all removable parts, sides of the Ice Bin, Auger, and surface of the aluminum casting.
11. Using the Cleaning Solution and the sponge brush provided, clean all interior surfaces of the ice chute and the ice chute feed through.
12. Repeat Step 6 for all exterior surfaces of the dispenser.
13. Using hot water, thoroughly rinse away the cleaning solution.
14. Wearing sanitary gloves, soak a clean cloth towel in Sanitizing Solution and wash all surfaces of removable parts, sides of the Ice Bin, Auger, and surface of the aluminum casting.
15. Using the Sanitizing Solution and the sponge brush provided, clean all interior surfaces of the ice chute and the ice chute feed through.
16. Repeat Step 10 for all exterior surfaces of the dispenser.
17. Wearing sanitary gloves, reassemble all removable parts. Ensure agitator clip is locked.
18. Fill Unit with ice and replace Top Cover.
19. Reconnect Dispenser to power source.

Cleaning and Sanitizing Syrup Lines - Bag in Box

NOTE

Extended lengths of product lines may require more time to flush and rinse lines.

1. Disconnect the syrup quick disconnect coupling from the syrup packages and connect the coupling to a bag valve removed from an empty Bag-in-Box (BIB) package.
2. Place syrup lines, with BIB connectors, in a bucket of warm water.
3. Activate each valve to fill the lines with warm water and flush out syrup remaining in the lines.
4. Prepare Cleaning Solution described on page 13.
5. Place syrup lines, with BIB connectors, into cleaning solution.
6. Activate each valve until lines are filled with cleaning solution then let stand for ten (10) minutes.
7. Flush out cleaning solution from the syrup lines using clean, warm water.
8. Prepare Sanitizing Solution described above.
9. Place syrup lines into sanitizing solution and activate each valve to fill lines with sanitizer. Let sit for ten (10) minutes.
10. Reconnect syrup lines to BIB's and draw drinks to flush solution from the dispenser.
11. Taste the drink to verify that there is no off-taste. If off-taste is found, flush syrup system again.

⚠ CAUTION

Following sanitization, rinse with end-use product until there is no aftertaste. Do not use a fresh water rinse. This is a NSF requirement. Residual sanitizing solution left in the system creates a health hazard.

Ice Chute Cleaning

NOTE

It is recommended to perform this procedure monthly, or more often if desired. Use the cleaning solution described on page 13. An alternate solution of one part water to one part vinegar may be used to remove water spots and calcium deposits.

1. Turn off power to the dispenser.
2. Remove Merchandiser.
3. Remove Ice Chute Lever, then remove Splash Plate Assembly by lifting it up and out from the dispenser face.
4. Unhook the spring from the upper ice chute by pulling up and out.
5. Remove the lower chute by carefully spreading apart the arms of the lower chute.
6. Prepare the Cleaning Solution.
7. Soak the lower Ice Chute Assembly in the solution.
8. Using the Cleaning Solution and the sponge brush provided, clean the inside of the upper and lower chutes.
9. Rinse and dry the lower and upper Ice Chute Assembly thoroughly.
10. Reinstall the lower Ice Chute Assembly.
11. Reinstall Merchandiser and Splash Plate.
12. Reconnect power to the dispenser.

NOTE

Always remove the ice chute lever before removing the splash plate.

OPERATION AND MAINTENANCE

Programming and Setup Software

NOTE

Lancer reserves the right to make changes and updates as required. If you have any questions regarding the latest versions of programs, please contact your Lancer representative.

The Lancer FS30 has been factory preset to the settings necessary to comply with the brand/brand version of the unit requested by the customer.

Adjustments or upgrades should only be performed by trained personnel. For any upgrades, an upgrade kit may be purchased. The kit includes all of the hardware required for the upgrade, including bezels and valves.

INITIALIZATION SCREEN (BOOT UP ONLY)

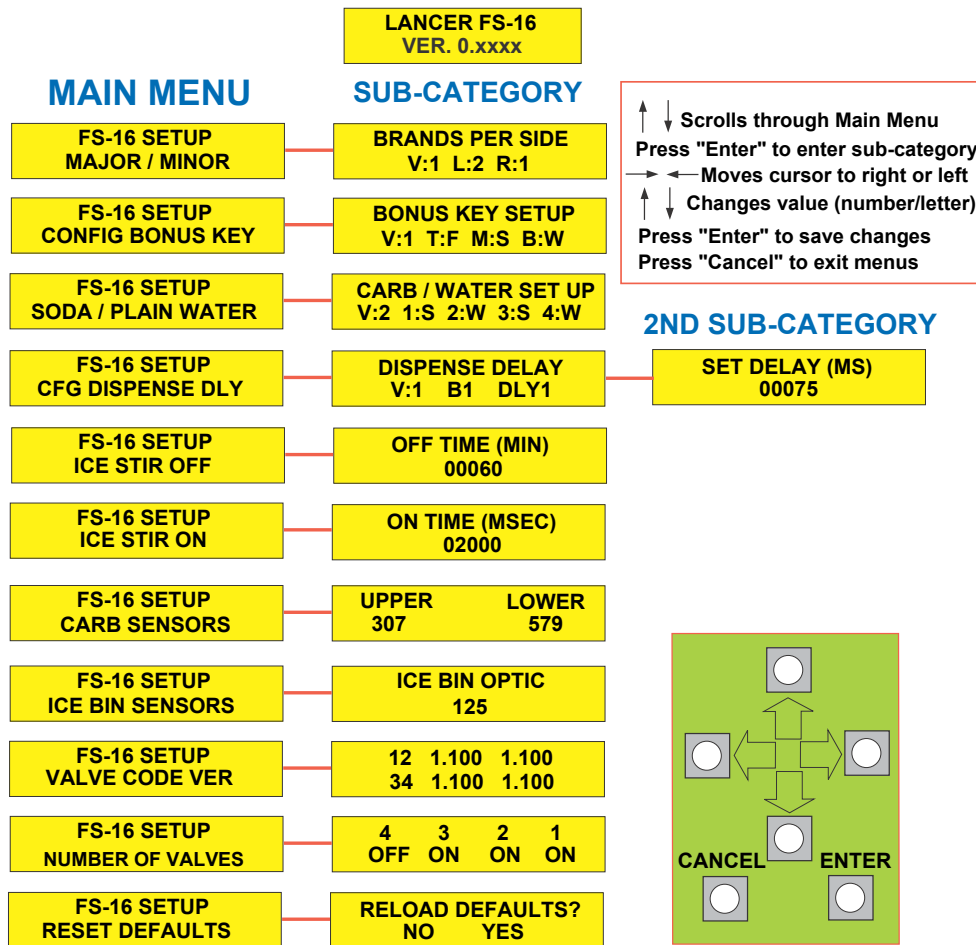

Valves can be adjusted by scrolling through the menus (see figure above) using the UP and DOWN arrows. By pressing the ENTER button, a submenu is revealed. In the submenu, the individual valves can be adjusted to the desired configuration.

Menus and Sub-menus



Bonus Flavors

1. Decide if the bonus flavors will be set to add an injected flavor to the brands or dispense carbonated water/plain water.
2. Choose the Valve number (1-4) by scrolling UP and DOWN arrows.
3. Use the LEFT and RIGHT arrows to shift to the Top, Middle, or Bottom "bonus" flavors categories.
4. Press the UP and DOWN arrows under Top, Middle, or Bottom to select it as an injected flavor, carbonated Soda water, or plain Water.
5. Press ENTER to finalize settings. Panel lights should confirm finalized configurations.

Brands

1. Decide how the brands will be setup.
2. Choose the Valve number (1-4) by scrolling UP and DOWN arrows.
3. Use the LEFT and RIGHT arrows to shift to the Left or Right categories. The Left or Right categories are set with the assumption that you are looking at them from the front.
4. Press UP and DOWN arrows under Left (1-2) or Right (1-2) to select the brand per side as a single or double. For example, for bezel PN 05-2120, V:1 L:1 R:2

Purging the Carbonation System

NOTE

Purge the carbonator tank whenever carbonation issues occur.

1. Turn off CO₂ supply.
2. Turn off power to the unit. Unplug the carbonator harness from the power supply.
3. Open the relief valve until water is coming out. Close the relief valve, checking for any remaining air in the tank.
4. Allow the carbonator tank to fill with plain water by way of the water booster.
5. Once the tank is full, turn the power back on and purge the system by dispensing a carbonated drink. You should only get plain water as the CO₂ is still off. Dispense several times.

Soda/Water

1. Decide which switch locations will be carbonated and/or non-carbonated drinks.
2. Choose the Valve number (2-3) by scrolling the UP and DOWN arrows.
3. Use the LEFT and RIGHT arrows to shift to the number categories (1-4). The number categories correspond to the brand location (per valve) that is being configured.
4. Press the UP and DOWN arrows under the number to select if that brand will be carbonated Soda or non-carbonated plain Water. If a single brand per side, only number 1 and/or 3 need to be set.

Automatic Agitation

1. Each Series 14400 ice beverage dispenser is equipped with automatic agitation for the ice bin. The unit is shipped with timing set at two seconds (2000 milliseconds) ON every sixty minutes for cubed ice. The unit is shipped with timing set at four seconds (4000 milliseconds) ON every 150 minutes for pellet ice.

6. Turn on the CO₂ supply
7. Turn off the power in order to reconnect the pump harness. Turn power back on.
8. Dispense soda at valve until the carbonator pump comes on. Release the button, allow the carbonator to fill and stop (usually a few seconds). Repeat this process until the water is carbonated (about five cycles).
9. Place dispenser back into service.

NOTE

To check for CO₂ leaks, close the valve on the CO₂ cylinder and observe if the pressure to the system drops with the cylinder valve closed for five minutes. Open the cylinder valve after check.

Carbonator Pump Modifications

NOTE

The electric, positive displacement rotary vane pump with 170 PSI bypass should only be serviced by trained personnel. To achieve optimum carbonation, use filtered water with the pump.

1. Turn off power to the dispenser.
2. Remove drip tray and splash plate.
3. Turn off water.
4. Turn the CO₂ off, activate the relief valve.
5. Once the pressure has been released, untighten the inlet/outlet nuts on the pump.
6. Unscrew the mounting bracket.
7. Part should easily slide out for replacement or maintenance.

TROUBLESHOOTING

Valve/Flavor Shot Troubleshooting

TROUBLE	CAUSE	REMEDY
No product when switch is activated. (Switch panel does not light up when activated.)	<ol style="list-style-type: none"> 1. Keyswitch is off, or keyswitch harness is disconnected. 2. 9-in valve harness is disconnected. 3. Defective switch assembly. 4. No power to unit 	<ol style="list-style-type: none"> 1. Turn keyswitch on and/or reconnect keyswitch harness. 2. Turn off power, reconnect 9-pin harness, and restore power. 3. Replace switch assembly. 4. Check internal breaker and incoming power
No product when switch is activated. (Switch panel does light up when activated)	<ol style="list-style-type: none"> 1. 25-pin valve harness is disconnected. 2. Defective switch assembly 	<ol style="list-style-type: none"> 1. Turn off power, reconnect 25-pin harness, and restore power. 2. Replace switch assembly.
Water only dispensed, no syrup. Or syrup only dispensed, no water.	<ol style="list-style-type: none"> 1. Syrup BIB empty. 2. Water or syrup shutoff on mounting block not fully open. 3. Improper or inadequate water or syrup supply. 4. CO₂ pressure to syrup pump too low. 5. Stalled or inoperative BIB pump. 6. Kinked line. 7. CO₂ regulator malfunction. 	<ol style="list-style-type: none"> 1. Replace syrup BIB as required. 2. Open shutoff completely. 3. Remove valve from mounting block & open shutoffs slightly. Check water & syrup supply. If no supply, check unit for other problems. Ensure BIB connection is engaged. 4. Check the CO₂ pressure to the pump to ensure it is between 70-80 PSI (0.483-0.552 MPA). 5. Check CO₂ pressure and/or replace pump. 6. Remove kink or replace line. 7. Repair or replace CO₂ regulator as required.
Syrup only dispensed. No water, but CO ₂ gas dispensed with syrup.	<ol style="list-style-type: none"> 1. Improper water flow to dispenser. 2. Carbonator pump motor has timed out. 3. Liquid level probe not connected properly to PCB. 4. Defective PCB assembly. 5. Defective liquid level probe. 6. Weak or defective carbonator pump. 	<ol style="list-style-type: none"> 1. Check for water flow to dispenser. 2. Reset by turning the unit OFF, then ON by using the circuit breaker on the power supply or momentarily unplugging unit. 3. Check connections of liquid level probe to PCB assembly. 4. Replace PCB assembly. 5. Replace liquid level probe. 6. Replace pump.

TROUBLE	CAUSE	REMEDY
Excessive foaming.	<ol style="list-style-type: none"> 1. No ice in bin. 2. Incoming water or syrup temperature too high. 3. CO₂ pressure too high. 4. Water flow rate too high. 5. Nozzle and diffuser not clean. 6. Air in BIB lines. 	<ol style="list-style-type: none"> 1. Fill bin with ice and allow coldplate to re-stabilize. 2. Correct prior to dispenser. 3. Adjust CO₂ pressure downward, but not less than 70 PSI (0.483 MPA). 4. Re-adjust and reset ratio. 5. Remove and clean. 6. Bleed air from BIB lines.
Low or no carbonation.	<ol style="list-style-type: none"> 1. Low or no CO₂. 2. Low water pressure. 3. Worn or defective carbonator pump. 4. Backflow preventer not allowing water to flow. 5. Probe malfunctioning. 6. PCB malfunctioning. 	<ol style="list-style-type: none"> 1. Check CO₂ supply. Adjust CO₂ pressure to 70 PSI (0.483 MPA). 2. Need water booster kit. 3. Replace carbonator pump. 4. Replace backflow preventer, noting the flow direction arrow from pump to coldplate. 5. Replace probe. 6. Replace PCB.
Erratic ratio.	<ol style="list-style-type: none"> 1. Incoming water and/or syrup supply not at minimum flowing pressure. 2. Foreign debris in water and/or syrup flow control. 3. CO₂ regulator malfunction. 	<ol style="list-style-type: none"> 1. Check pressure and adjust. 2. Remove flow control from suspected valve and clean out any foreign material to ensure smooth spool movement. 3. Repair or replace CO₂ regulator.
Insufficient soda flow (carbonated drinks).	<ol style="list-style-type: none"> 1. Insufficient CO₂ supply pressure. 2. Shutoff on mounting block is not fully open. 3. Foreign debris in soda flow control. 	<ol style="list-style-type: none"> 1. Verify incoming CO₂ pressure is between 70 PSIG (0.483 MPA) and 80 PSIG (0.552 MPA) 2. Open shutoff fully. 3. Remove soda flow control from valve and clean out any foreign material to ensure smooth spool movement.
Insufficient water flow (plain water drinks).	<ol style="list-style-type: none"> 1. Insufficient incoming supply pressure. 2. Shutoff on mounting block not fully open. 3. Foreign debris in water flow control. 4. Water filtration problem. 	<ol style="list-style-type: none"> 1. Verify incoming supply water pressure to plain water inlet is a minimum of 50 PSI (0.345 MPA) and a maximum of 100 PSI (0.689 MPA). 2. Open shutoff fully. 3. Remove water flow control from valve and clean out any foreign material to ensure smooth spool movement. 4. Service water system as required.
Insufficient syrup flow.	<ol style="list-style-type: none"> 1. Insufficient CO₂ pressure to BIB pumps. 2. Shutoff on mounting block not fully open. 3. Foreign debris in syrup flow control. 4. Defective BIB pump. 	<ol style="list-style-type: none"> 1. Adjust CO₂ pressure to BIB pumps to 80 PSI (0.552 MPA) (min. 70 PSI (0.483 MPA)). Do not exceed manufacturer's recommendations. 2. Open shutoff fully. 3. Remove syrup flow control from valve and clean out any foreign material to ensure smooth spool movement. 4. Replace pump.

TROUBLE	CAUSE	REMEDY
Water leakage around nozzle.	1. Damaged or improperly installed o-ring on nozzle.	1. If damaged, replace. If improperly installed, adjust.
Miscellaneous leakage.	1. Gap between parts. 2. Damaged or improperly installed o-rings.	1. Tighten appropriate retaining screws. 2. Replace or adjust appropriate o-rings.
Miscellaneous leakage.	1. Gap between parts. 2. Damaged or improperly installed o-rings.	1. Tighten appropriate retaining screws. 2. Replace or adjust appropriate o-rings.
Water continually leaking at connections.	1. Loose water connections. 2. Flare seal washer leaks.	1. Tighten water connections. 2. Replace flare seal washer.
Valves do not operate.	1. Keyswitch is off, or keyswitch harness is disconnected. 2. Circuit breaker tripped. 3. Unit not plugged in.	1. Turn keyswitch and/or make sure keyswitch harness is connected. 2. Reset circuit breaker. 3. Plug in dispenser
Valve will not shut off.	1. Debris in solenoid seat. 2. Solenoid plunger sticking.	1. Activate valve a few times to free debris. Remove the solenoid coil and plunger and clean out foreign material. 2. Replace solenoid coil.

Ice Bin/Ice Chute/Carbonator Pump Troubleshooting

TROUBLE	CAUSE	REMEDY
Water in ice bin.	1. Coldplate drain is obstructed.	1. Remove splash plate and drip tray to obtain access to drain tubes and clear accordingly.
Water leaking from ice door.	1. Securing screws loosened. 2. Ice door improperly seated.	1. Tighten screws. 2. Reattach door assembly to dispenser.
Push ice chute; no response.	1. Dispenser not connected to power source. 2. Wiring harness not plugged in. 3. PC board defective. 4. Malfunctioning power supply.	1. Connect dispenser to power source. 2. Plug in wiring harness. 3. Replace PC board. 4. Check voltage to power supply. Check fuses.
Push ice chute, ice door opens but motor does not run.	1. Wiring harness not plugged in. 2. PC board defective. 3. Motor defective.	1. Plug in wiring harness. 2. Replace PC board. 3. Replace motor.
Push ice chute, motor runs but ice door does not open.	1. Solenoid not connected to PC board. 2. Solenoid defective. 3. PC board defective.	1. Connect solenoid to PC board. 2. Replace solenoid. 3. Replace PC board.
Push ice chute, ice door opens, motor runs, but ice does not dispense, or ice is of poor quality.	1. Dispenser is out of ice. 2. Agitator pin is missing or damaged. 3. Poor ice quality. 4. Key not installed on agitation shaft.	1. Fill dispenser with ice. 2. Replace agitator pin. 3. Service ice machine. 4. Install key on agitation shaft.

TROUBLE	CAUSE	REMEDY
Noisy/cavitating carbonator pump.	1. Insufficient incoming water supply pressure.	1. Verify incoming supply water pressure to carbonator pump is min. of 25 PSI (0.172 MPA), max. of 50 PSI (0.345 MPA).
Circuit breaker tripping.	<ol style="list-style-type: none"> 1. Valve wire harnesses shorted to itself or faucet plate. 2. Controller PCB is bad. 3. Secondary wire harness is shorted. 4. Power supply is bad. 	<ol style="list-style-type: none"> 1. Detect short by disconnecting valve harnesses from switch panel (2 25-pin harnesses and 2 9-pin harnesses). Restore power. If breaker does not trip, then find and replace shorted harness. If breaker still trips, reinstall the eight harnesses and proceed to Step 2. 2. Detect by disconnecting the white 5-pin harness from the controller PCB. Restore power. If breaker does not trip, then replace controller PCB. If breaker still trips, reinstall the white 5-pin harness and proceed to Step 3. 3. Locate short from a motor or solenoid harness and replace as necessary. 4. Detect short by disconnecting all harnesses connected to power supply. Restore power. If breaker still trips, replace power supply.

Remote Syrup/Flavor Shot Pump Troubleshooting

TROUBLE	CAUSE	REMEDY
BIB pump does not operate when dispensing valve is opened.	<ol style="list-style-type: none"> 1. Out of CO₂, CO₂ not turned on, or low CO₂ pressure. 2. Out of syrup. 3. BIB connector not tight. 4. Kinks in syrup or gas lines. 	<ol style="list-style-type: none"> 1. Replace CO₂ supply, turn on CO₂ supply, or adjust CO₂ pressure to 70-80 PSI (0.483-0.552 MPA). 2. Replace syrup supply. 3. Fasten connector tightly. 4. Straighten or replace lines.
BIB pump operating, but no flow.	<ol style="list-style-type: none"> 1. Leak in syrup inlet or outlet line. 2. Defective BIB pump. 	<ol style="list-style-type: none"> 1. Replace line. 2. Replace BIB pump.
BIB pump continues to operate when bag is empty.	<ol style="list-style-type: none"> 1. Leak in suction line. 2. Leaking o-ring on pump inlet fitting. 3. Defective syrup BIB pump. 	<ol style="list-style-type: none"> 1. Check BIB connector, if still leaking then replace line. 2. Replace o-ring 3. Replace defective pump.
BIB pump fails to restart after bag replacement.	<ol style="list-style-type: none"> 1. BIB connector not on tightly. 2. BIB connector is stopped up. 3. Kinks in syrup line. 	<ol style="list-style-type: none"> 1. Tighten BIB connector. 2. Clean out or replace BIB connector. 3. Straighten or replace line.
BIB pump fails to stop when dispensing valve is closed.	<ol style="list-style-type: none"> 1. Leak in discharge line or fittings. 2. Empty BIB. 3. Air leak on inlet line or bag connector. 	<ol style="list-style-type: none"> 1. Repair or replace discharge line. 2. Replace BIB. 3. Repair or replace.

ILLUSTRATIONS AND PART LISTINGS

Main Unit Assembly

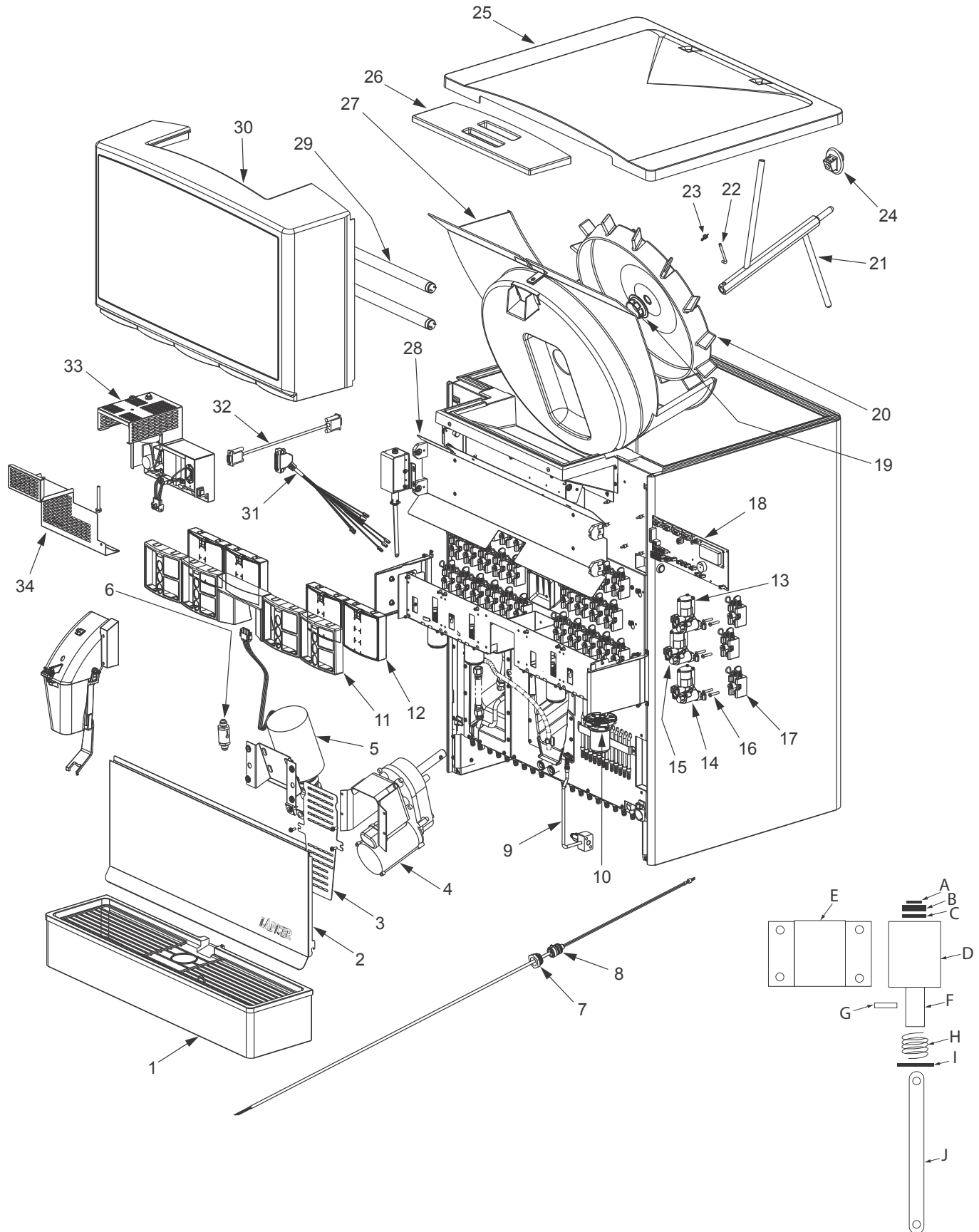

Part No.	Description
85-14808-12	IBD, Above Counter Multi Brand Series 14800, 115V/60Hz, 8 brands / 12 flavors
85-14810-12	IBD, Above Counter Multi Brand Series 14800, 115V/60Hz, 10 brands / 12 flavors
85-14812-12	IBD, Above Counter Multi Brand Series 14800, 115V/60Hz, 12 brands / 12 flavors
85-14814-12	IBD, Above Counter Multi Brand Series 14800, 115V/60Hz, 14 brands / 12 flavors
85-14816-12	IBD, Above Counter Multi Brand Series 14800, 115V/60Hz, 16 brands / 12 flavors
85-14808N-12	IBD, Above Counter Multi Brand Series 14800, 115V/60Hz, 8 brands / 12 flavors, Pellet
85-14810N-12	IBD, Above Counter Multi Brand Series 14800, 115V/60Hz, 10 brands / 12 flavors, Pellet
85-14812N-12	IBD, Above Counter Multi Brand Series 14800, 115V/60Hz, 12 brands / 12 flavors, Pellet
85-14814N-12	IBD, Above Counter Multi Brand Series 14800, 115V/60Hz, 14 brands / 12 flavors, Pellet

Item	Part No.	Description			
1	82-4183	Drip Tray Assy,30	15	82-3823	Valve Assy, LFCV, 4.5, Syrup, Black
2	30-8364/01	Splash Plate	16	04-1089	Screw, 10 - 32 x 1.000, RH, PH/SL
3	30-6147	Cover, Motor, IBD	17	82-2317/01	Block Mounting Assy, SGL
4	82-3688	Motor Assy	18	82-4372	Kit, Controller Board,FS30
-	91-0165/01	Motor, Agitator, IBD	19	02-0406/01	Seal, Shaft, Motor, IBD
5	82-3196	Motor Assy, Carbonator	20	82-3556	Dispensing Wheel, HEX, IBD
-	86-0084-SP	Pump Assy	21	23-1373	Agitator Assy, HEX
-	91-0063	Motor, Carbonator	22	10-0762	Pin, Agitator, 1/4", PASS
6	17-0611	Check Valve, Vented, 5/8 x 18	23	03-0368	Retainer, RUE-14-S
7	01-2214	Nut, Swivel, Probe, Carb	24	05-1555	Bearing, Agitator, Rear, IBD
8	52-2751/02	Body, Probe, Sub Assy, Carb	25	05-1606	Lid, Back, IBD30, Round
9	82-3370/02	CO ₂ Assy, Inlet/P-OFF	26	05-1476/01	Lid, Front, IBD, Round
-	54-0066	Relief Valve Assy	27	05-1310/02	Shroud, Dispensing Wheel, Modified
10	54-0289	Nozzle Assy, Multi-Flavor, STHL	28	82-3994/01	Reflector Assy, FS30
-	05-1855/01	Nozzle, Multiflavor	-	12-0104/01	Indicator, LED Panel Mount
-	02-0231	O-ring	-	52-3133	Ballast Assy,230V,2 bulbs
11	05-2120	Bezel, Multi-Brand, 1L/2R	29	12-0503	Bulb, Fluorescent, 26", T8, CW
-	05-2121	Bezel, Multi-Brand, 2L/1R	30	82-3705	Merchandiser Assy, FS - No graphic
-	05-2122	Bezel, Multi-Brand, 1L/1R	31	52-3433	Harness,Valve,25-PIN,FS/ADA
-	05-2058	Bezel, Multi-Brand, 2L/2R	32	52-2692/01	Harness, Control-to-Valve, 9-PIN
12	82-3286/02	Switch Assy, MB, 2L/2R	33	82-3284	Power Supply
13	82-3820	Valve Assy, LFCV, 0.2, Syrup Injection, Natural	34	30-8871/02	Cover, power Supply
14	82-3824	Valve Assy, LFCV, 4.5, Soda/Water, Gray	35	82-3987	Ice Chute Assy, Mercury

ICE DOOR SOLENOID ASSEMBLY:

Item	Part No.	Description			
A	03-0086	Ring, Retaining (5304-18)	F	23-1380	Plunger Assy
B	04-0328	Washer, Rubber	G	10-0496	Pin, Solenoid Assy
C	04-0327	Washer, Flat	H	03-0110	Spring, Solenoid
D	12-0195	Solenoid, D-90	I	03-0111	Ring, Retaining (5133-62)
E	30-5165	Bracket, Solenoid	J	30-8356	Linkage, Door, FS

Ice Chute Assembly

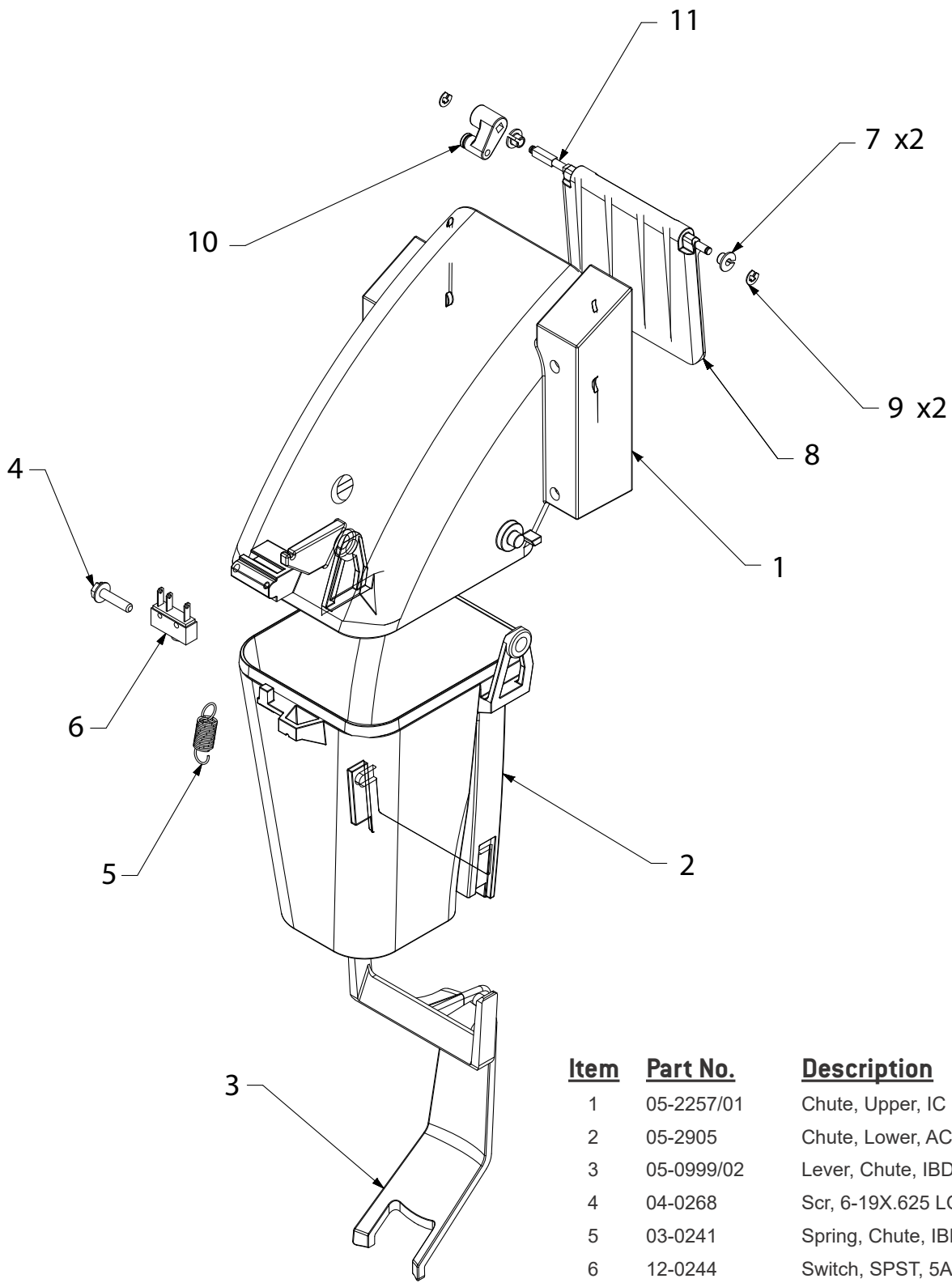

<u>Item</u>	<u>Part No.</u>	<u>Description</u>
1	05-2257/01	Chute, Upper, IC
2	05-2905	Chute, Lower, ACIB
3	05-0999/02	Lever, Chute, IBD
4	04-0268	Scr, 6-19X.625 LG, PLSTI, HHSW/W
5	03-0241	Spring, Chute, IBD
6	12-0244	Switch, SPST, 5A, 250V, MDM
7	05-0359/01	Bushing, .123 ID x .187 OD, NYLN
8	05-0928/02	Trap Door, IBD
9	03-0113	Ring, Retaining
10	05-0546	Lever, Door
11	10-0732	Shaft, Ice Chute Door, IC

Pellet Ice Bin Assembly

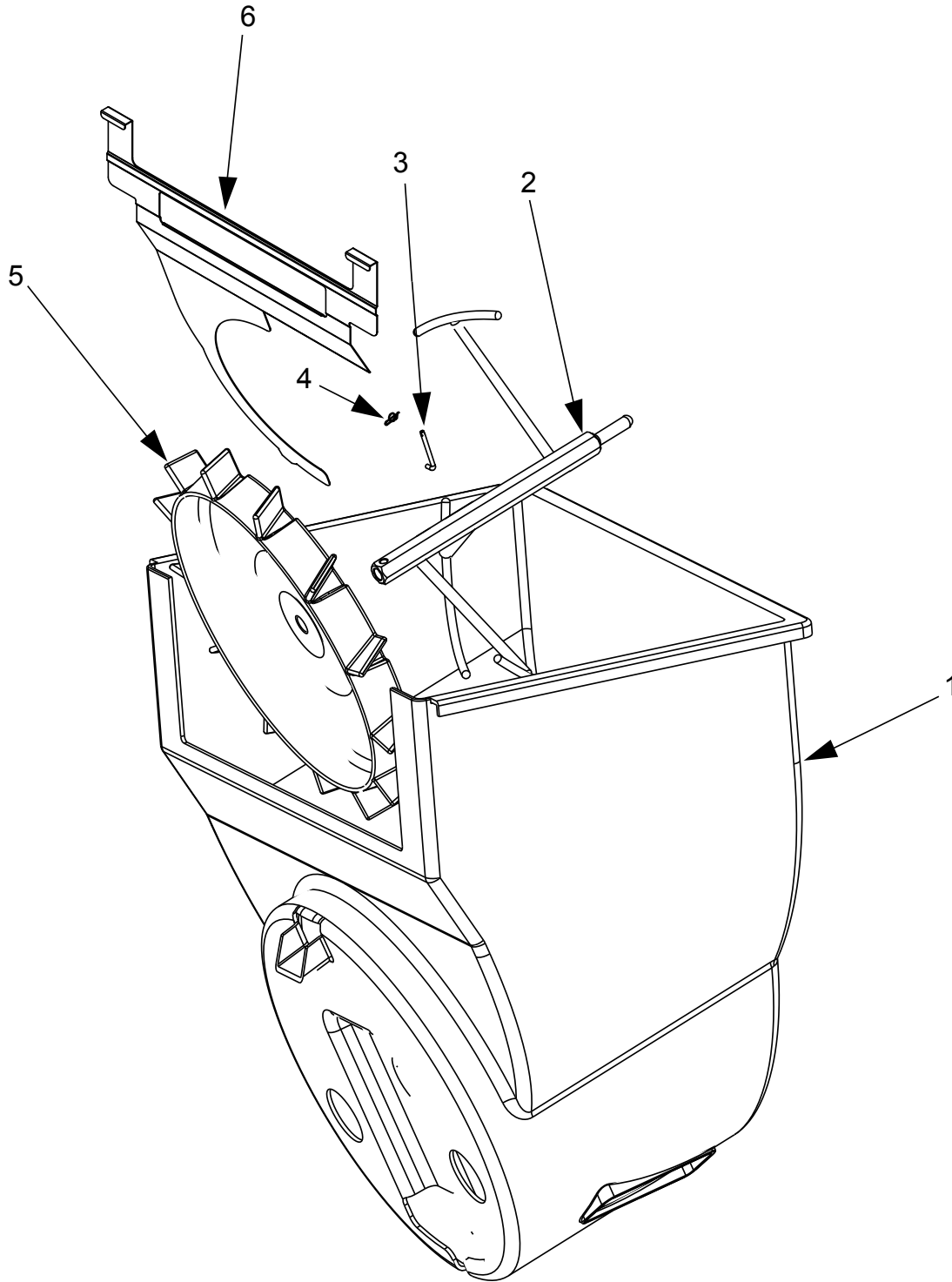

<u>Item</u>	<u>Part No.</u>	<u>Description</u>
1	05-2325/01	Ice Shroud, IC
2	23-1401/01	Agitator Assy, Helical, IC
3	10-0762	Pin, Hex Design, FS-16
4	03-0368	Retainer, Pin, Agitator, IBD
5	82-3651	Dispensing Wheel Assy, Pellet Ice
6	30-9801/01	Shield, Nugget, I

Lancer Flow Control Valve (LFCV)

LFCV VALVE ASSEMBLIES:

<u>Item</u>	<u>Description</u>
82-3820	LFCV, BONUS INJECTOR
82-3823	LFCV, 3.0 - 4.5, SYRUP ASSY
82-3824	LFCV, 3.0 - 4.5, SODA/WATER ASSY

LFCV KIT:

82-4020/01	LFCV REBUILD KIT
------------	------------------

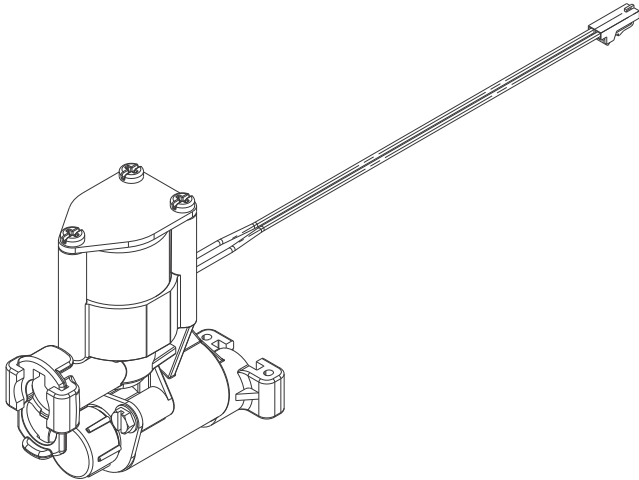

LFCV SPARE PARTS:

<u>Item</u>	<u>Part No.</u>	<u>Description</u>
1	10-0870/01	PLUG NUT, SOLENOID, 2PK
2	02-0538	O-RING
3	12-0364/04-01	COIL, LFCV
4	23-1442/01	CORE ASSY, SIMRIT COMPOUND C
5	03-0180/02	SPRING, CORE
6	02-0109	O-RING
7	05-1745/02	SEAT, LFCV
8	02-0133	O-RING

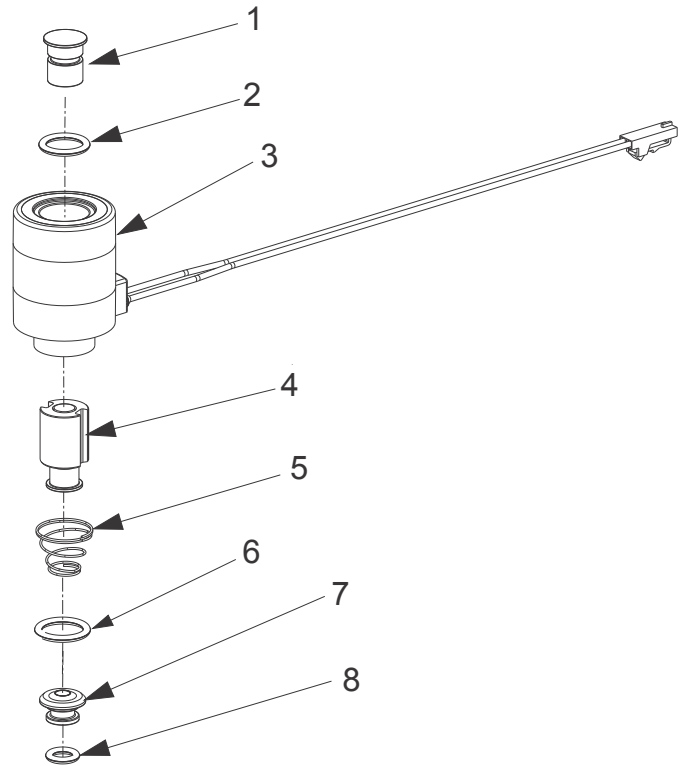

Wiring Diagram

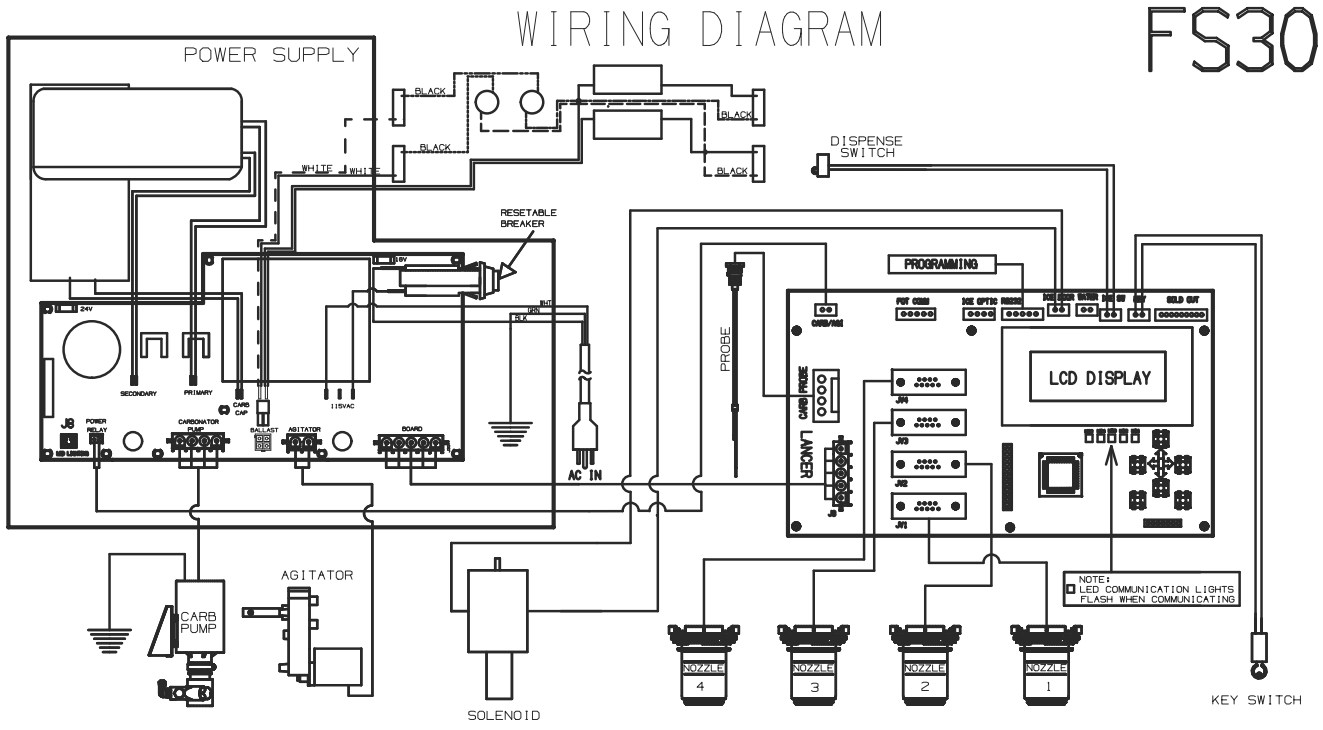

Plumbing Diagram

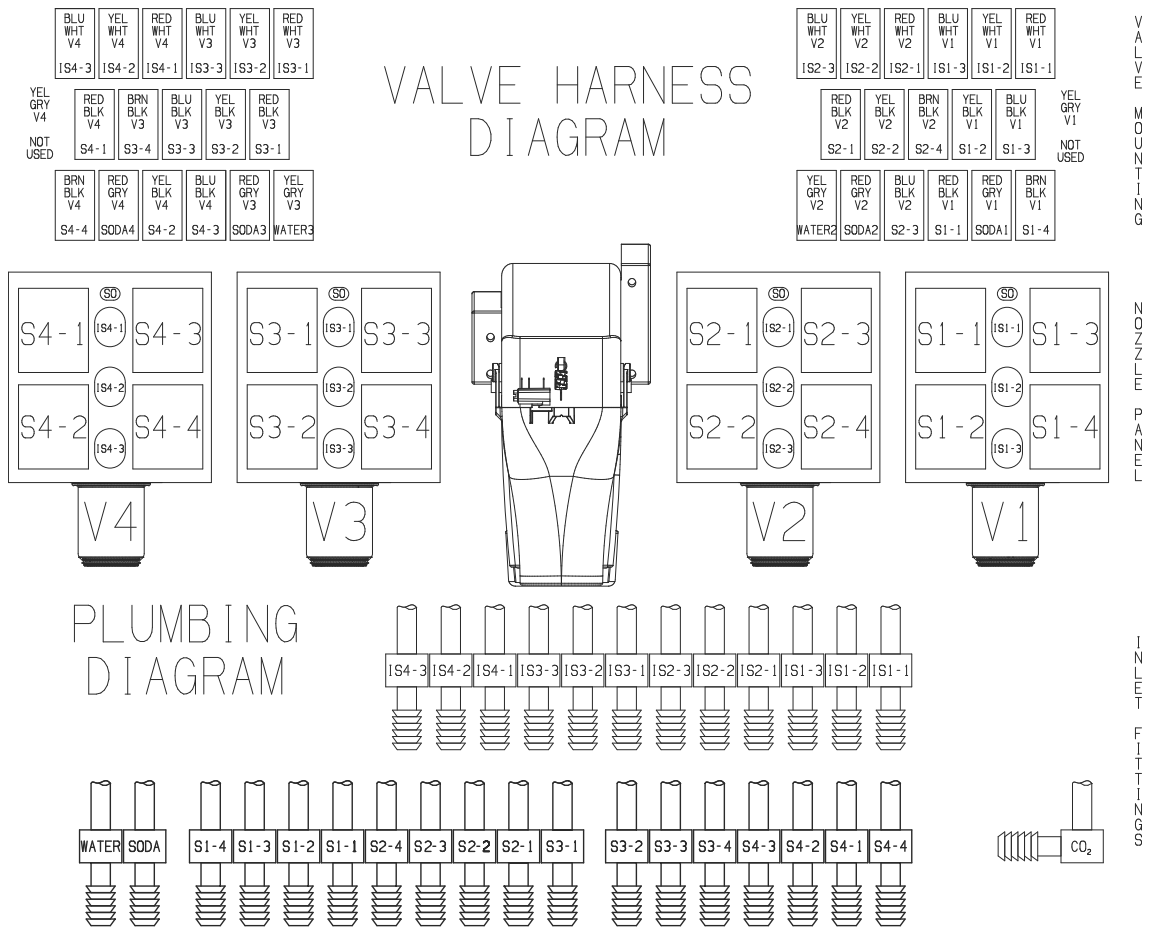

FS30 COUNTER CUTOUT

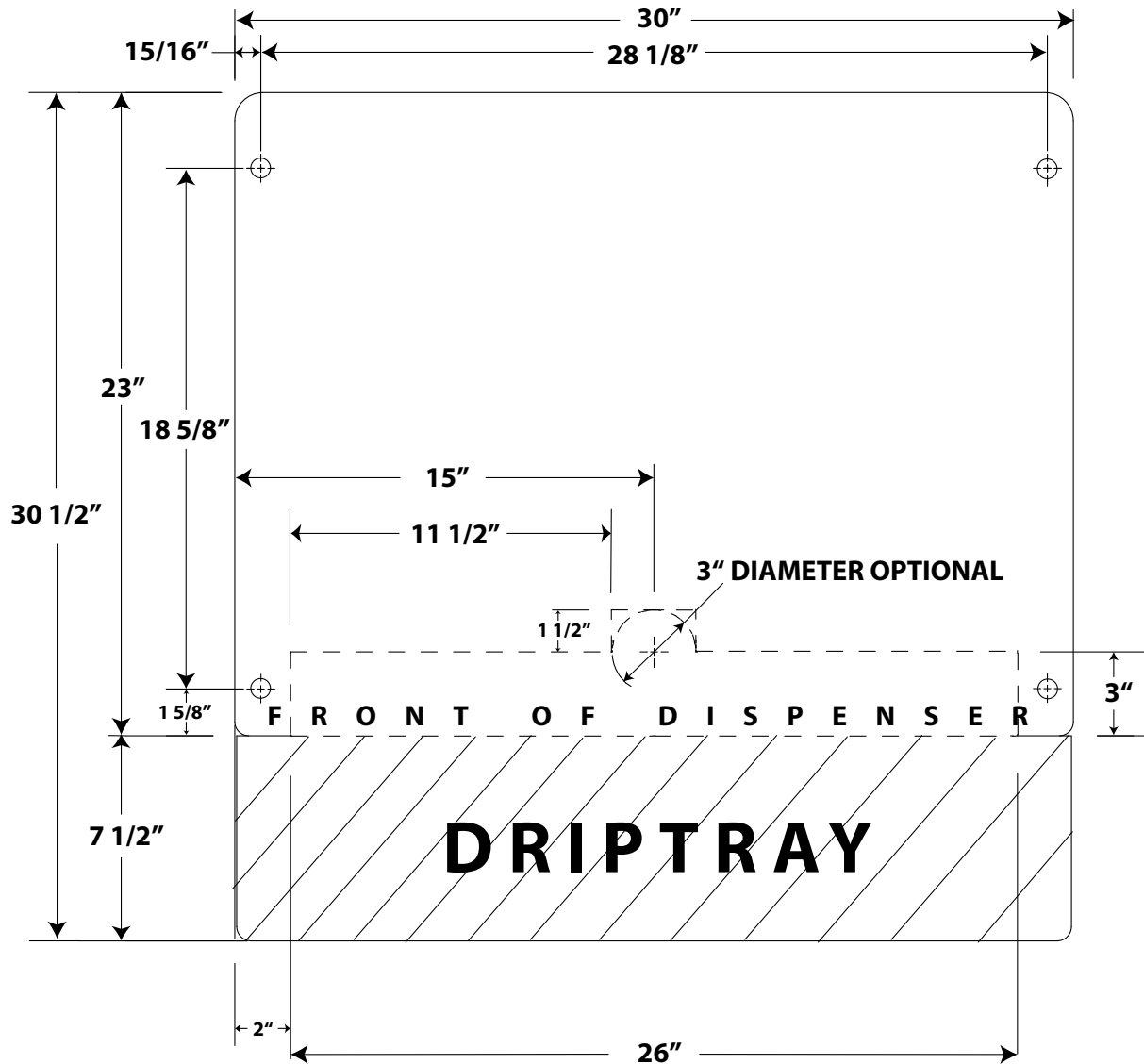

--- CUT OUT DASHED AREA
⊕ OPTIONAL HOLES FOR FASTENING DISPENSER TO COUNTER WITH SCREWS

Dispenser Disposal



To prevent possible harm to the environment from improper disposal, recycle the unit by locating an authorized recycler or contact the retailer where the product was purchased. Comply with local regulations regarding disposal of the refrigerant and insulation.



LANCER[®]

Lancer Corp.
800-729-1500
Technical Support/Warranty: 800-729-1550
custserv@lancercorp.com
lancercorp.com