

Ice-O-Matic[®]

SERVICE PARTS MANUAL

MODEL-ICE1405 Version 4 & 5

MODEL-ICE1406 Version 4 & 5

MODEL-ICE1407 Version 4 & 5

Includes 50Hz.and 3 phase Units



Ice-O-Matic
11100 East 45th Ave
Denver, Colorado 80239
Part Number 9081375-02

Date 6/12

ICE Series Service Parts

This parts list contains the service parts available for the ICE1400 Series listed below

ICE1406 A4-5, W4-5 and R4-5

ICE1405 A4-5, W4-5 and R4-5

ICE1407 A4-5, W4-5 and R4-5

Check the model number on the data plate and refer to the correct listing for the specific component.

Check carefully that the correct part is identified and ordered.

Table of Contents	Page 1
Exterior Panels	Page 2
Air Cooled	Page 4
Water Cooled	Page 6
Remote	Page 8
Control Box and Compressor Components	Page 10
Harvest Assist	Page 12
Water Pump/Float	Page 14
VRC Condenser	Page 16

**Ice-O-Matic
11100 East 45th Ave.
Denver Co. 80239
800-423-3367**

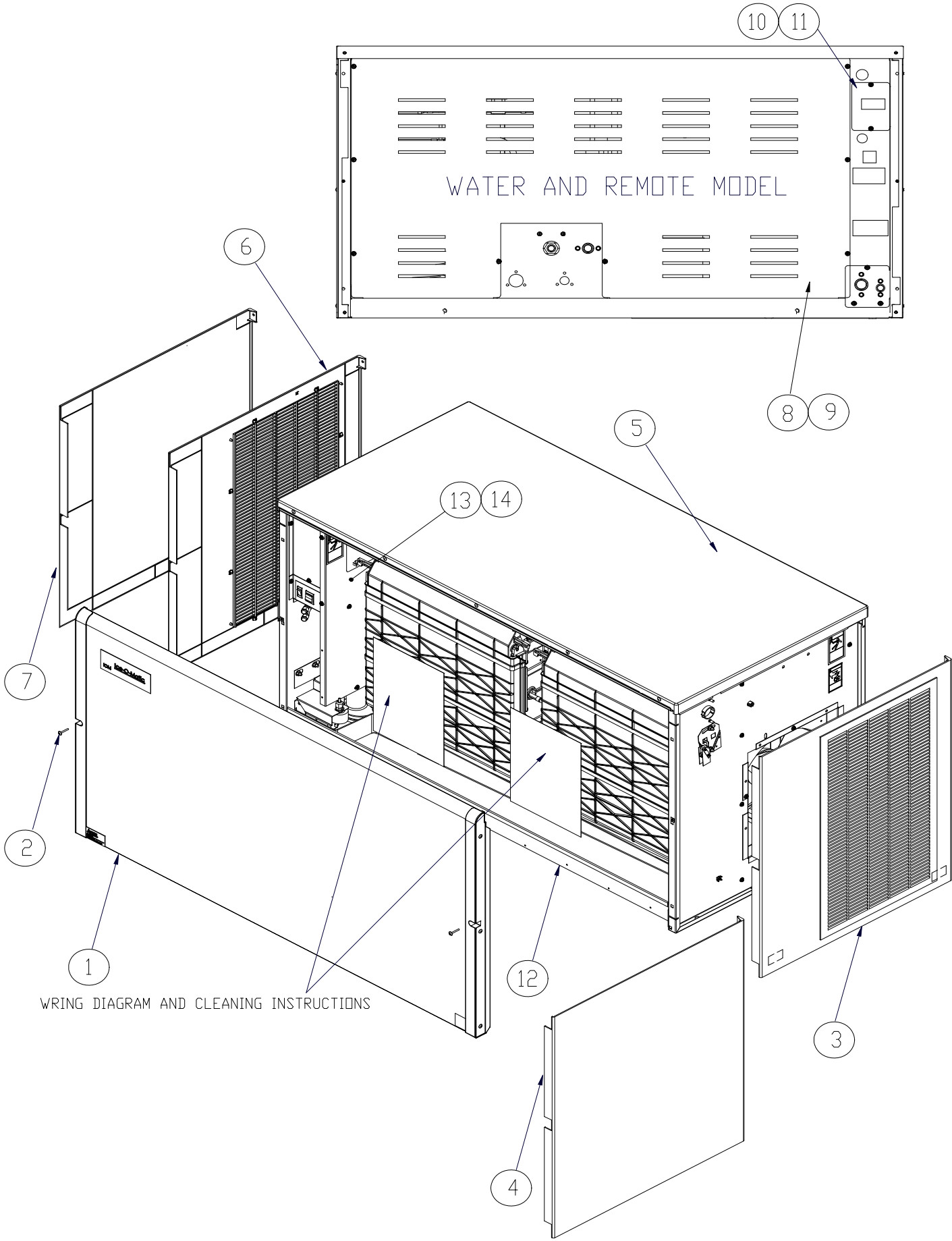

Item No.	Model Number			Description
	ICE1406	ICE1405	ICE1407	
1	2031511-03S	2031511-03S	2031511-03S	Front Panel
	9051562-03	9051562-03	9051562-03	Front Panel End Cap, Right Hand
	9051562-04	9051562-04	9051562-04	Front Panel End Cap, Left Hand
2	9031098-04	9031098-04	9031098-04	Front Panel Screws
3	2101428-02S	2101428-02S	2101428-02S	Right Hand Side Panel- Air Cooled Only
4	9051565-04	9051565-04	9051565-04	Right Hand Side Panel-Water Cooled and Remote Only
5	2101430-01S	2101430-01S	2101430-01S	Top Panel
6	2101428-04S	2101428-04S	2101428-04S	Left Hand Side Panel- Air Cooled Only
7	9051565-04	9051565-04	9051565-04	Left Hand Side Panel-Water Cooled and Remote Only
8	3021926-01	3021926-01	3021926-01	Rear Panel
9	9031046-01	9031046-01	9031046-01	Rear Cover Panel Screws
10	3013308-01	3013308-01	3013308-01	Junction Box Cover
11	9031046-01	9031046-01	9031046-01	Junction Box Cover Screws
12	3013315-01	3013315-01	3013315-01	Ice Deflector
13	3013294-01	3013294-01	3013294-01	Control Box Top Cover
14	3013293-01	3013293-01	3013293-01	Control Box Side Cover
15	N/A	3012931-02	N/A	Machine Compartment Cover

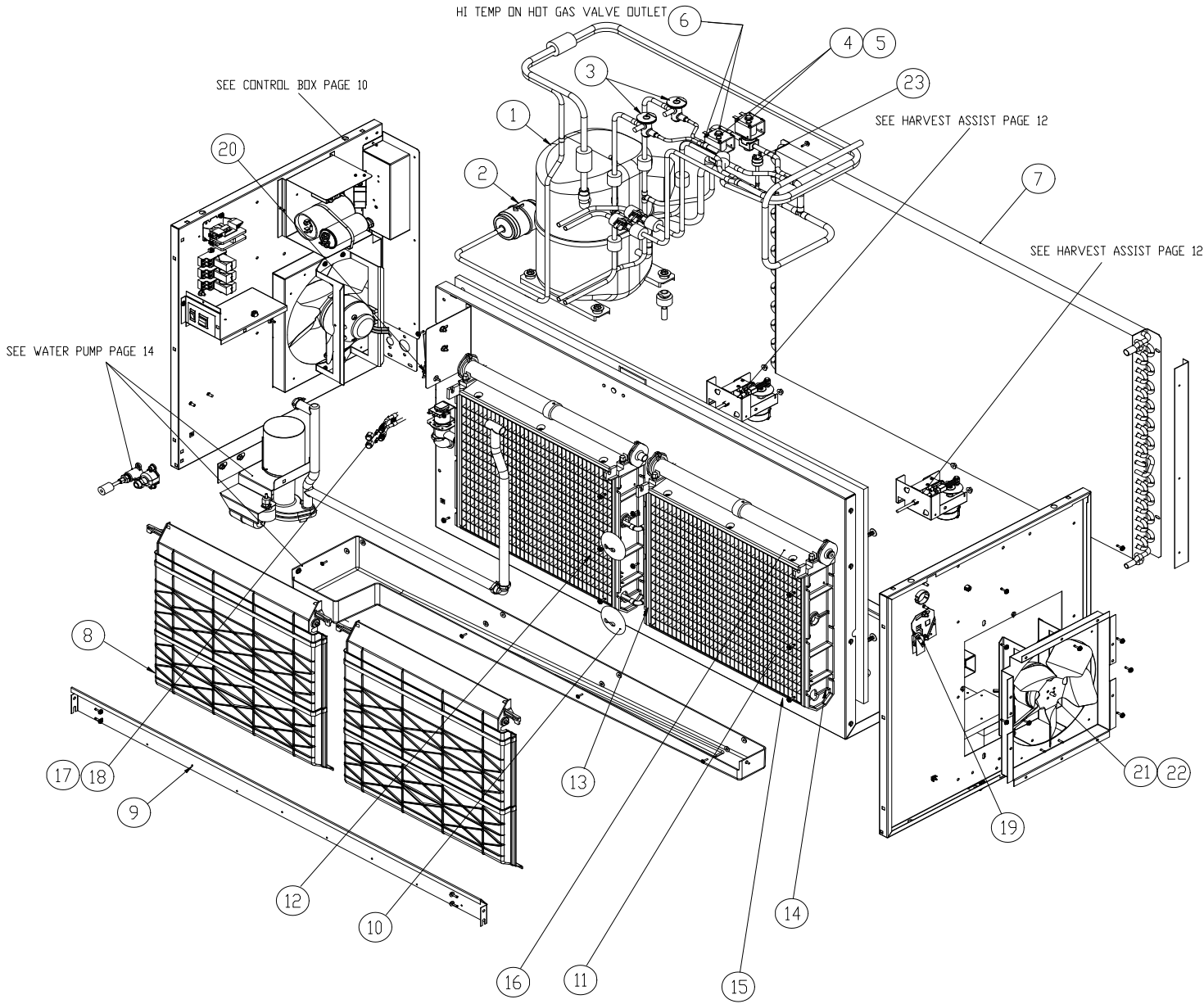

Item No.	Model Number			Description
	ICE1406A	ICE1405A	ICE1407A	
1	9181142-11	9181143-12	9181111-12	Compressor * See Notes Below
2	9151004-03	9151004-03	9151004-03	Filter Drier
3	9151150-01	9151150-01	9151150-01	Expansion Valve
4	9151123-02	9151123-02	9151123-02	Hot Gas Valve Body
5	9151123-04	9151123-04	9151123-04	Hot Gas Valve Coil
6	9041098-01	9041098-01	9041098-01	High Temperature Safety Control
7	9141132-01	9141132-01	9141132-01	Air Condenser
8	9051154-14	9051154-14	9051154-14	Evaporator Splash Curtain
9	3013315-01	3013315-01	3013315-01	Ice Deflector
10	9051237-02	9051237-02	9051237-02	Washer Tube
11	2051237-81	2051237-81	2051237-81	Evaporator Right Side Full Cube
11	2051237-82	2051237-82	2051237-82	Evaporator Right Side Half Cube
12	2051238-81	2051238-81	2051238-81	Evapoartor Left Side Full Cube
12	2051238-82	2051238-82	2051238-82	Evapoartor Left Side Half Cube
13	9051540-03	9051540-03	9051540-03	Evaporator Left Side Mounting Panel
14	9051540-04	9051540-04	9051540-04	Evaporator Right Side Mounting Panel
15	9051135-04	9051135-04	9051135-04	Water Return
16	9051135-05	9051135-05	9051135-05	Spillway
17	9091086-02	9091086-02	9091086-02	Valve Core
18	9091086-03	9091086-03	9091086-03	Valve Cap
19	9101124-02	9101124-02	9101124-02	Bin Switch Right Side (Cut Arm)
20	9101124-02	9101124-02	9101124-02	Bin Switch Left Side (Cut Arm)
21	9161078-03	9161078-02	9161078-03	Fan Motor
22	9131383-01	9131383-01	9131383-01	Fan Blade
23	9041096-01	9041096-01	9041096-01	Fan Control

* Note ICE1406 Air Cooled Compressor 9181111-11 is NLA, Reference Service Bulletin 12-08

* Note ICE1405 Air Cooled Compressor 9181094-12 is NLA, Reference Service Bulletin 12-16

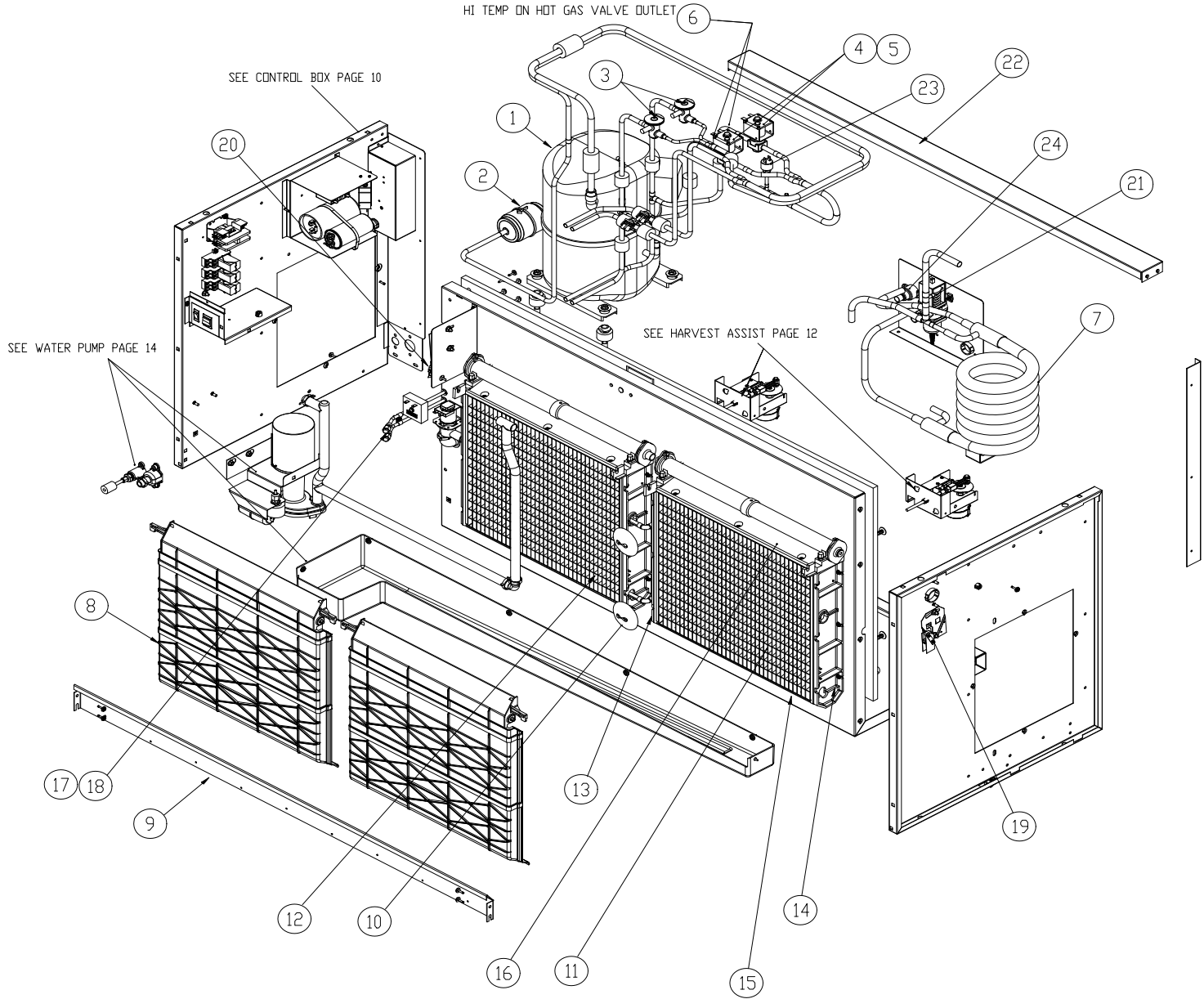

Item No.	Model Number			Description
	ICE1406W	ICE1405W	ICE1407W	
1	9181142-11	9181143-12	9181111-12	Compressor * See Notes Below
2	9151004-03	9151004-03	9151004-03	Filter Drier
3	9151150-01	9151150-01	9151150-01	Expansion Valve
4	9151123-02	9151123-02	9151123-02	Hot Gas Valve Body
5	9151123-04	9151123-04	9151123-04	Hot Gas Valve Coil
6	9041098-01	9041098-01	9041098-01	High Temperature Safety Control
7	9141061-02	9141061-02	9141061-02	Water Condenser
8	9051154-14	9051154-14	9051154-14	Evaporator Splash Curtain
9	3013315-01	3013315-01	3013315-01	Ice Deflector
10	9051237-02	9051237-02	9051237-02	Washer Tube
11	2051237-81	2051237-81	2051237-81	Evaporator Right Side Full Cube
11	2051237-82	2051237-82	2051237-82	Evaporator Right Side Half Cube
12	2051238-81	2051238-81	2051238-81	Evapoartor Left Side Full Cube
12	2051238-82	2051238-82	2051238-82	Evapoartor Left Side Half Cube
13	9051540-03	9051540-03	9051540-03	Evaporator Left Side Mounting Panel
14	9051540-04	9051540-04	9051540-04	Evaporator Right Side Mounting Panel
15	9051135-04	9051135-04	9051135-04	Water return
16	9051135-05	9051135-05	9051135-05	Spillway
17	9091086-02	9091086-02	9091086-02	Valve Core
18	9091086-03	9091086-03	9091086-03	Valve Cap
19	9101124-02	9101124-02	9101124-02	Bin Switch Right Side (Cut Arm)
20	9101124-02	9101124-02	9101124-02	Bin Switch Left Side (Cut Arm)
21	9041059-01	9041059-01	9041059-01	Water Regulating Valve
22	3013316-01	3013316-01	3013316-01	Rear Brace
23	9041091-01	9041091-01	9041091-01	High Pressure Control
24	9091063-02	9091063-02	9091063-02	Condenser Drain Fitting

* Note ICE1406 Water Cooled Compressor 9181111-11 is NLA, Reference Service Bulletin 12-08

* Note ICE1405 Water Cooled Compressor 9181094-12 is NLA, Reference Service Bulletin 12-16

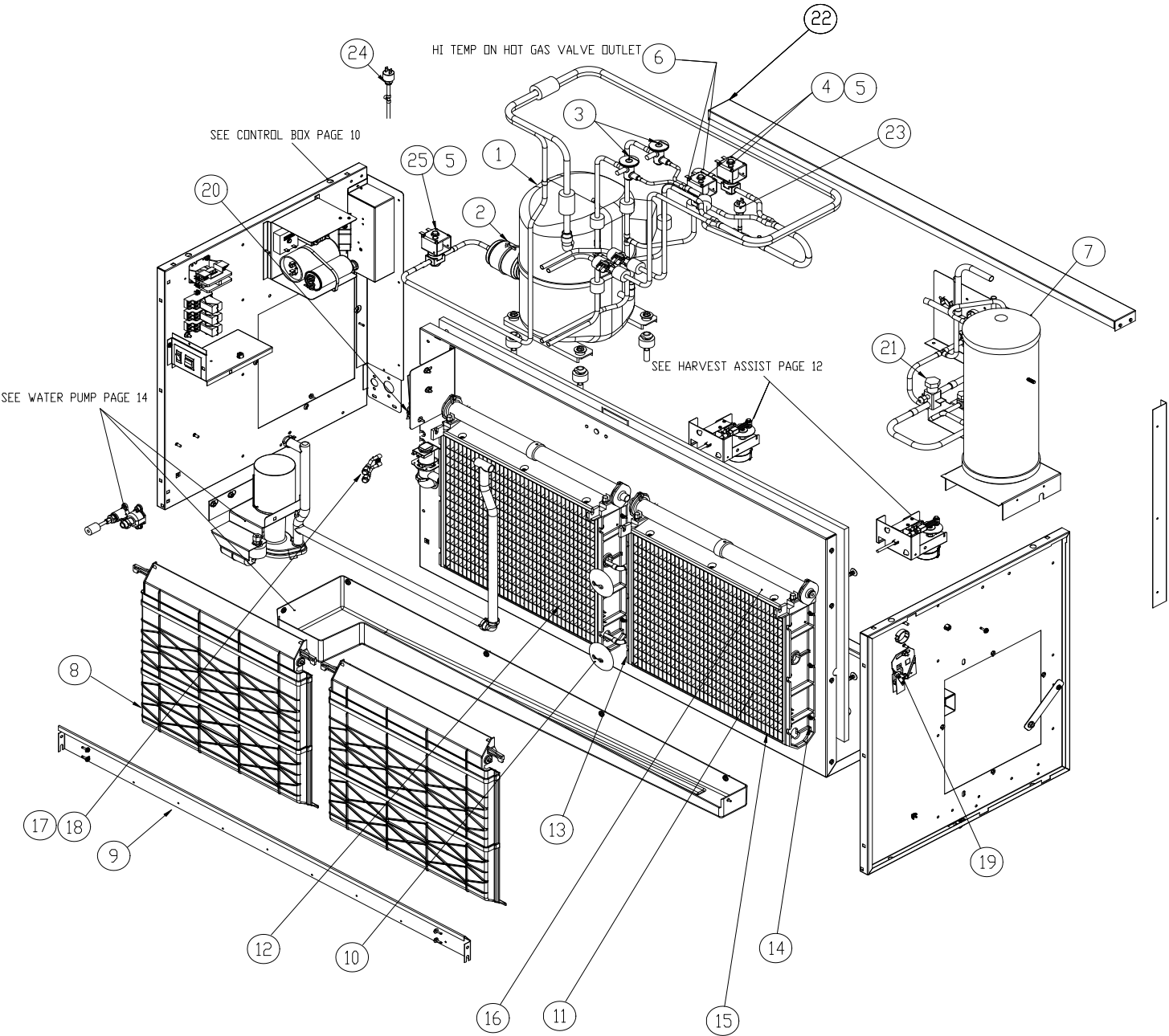

Item No.	Model Number			Description
	ICE1406R	ICE1405R	ICE1407R	
1	9181142-11	9181143-12	9181111-12	Compressor * See Notes Below
2	9151004-03	9151004-03	9151004-03	Filter Drier
3	9151150-01	9151150-01	9151150-01	Expansion Valve
4	9151123-02	9151123-02	9151123-02	Hot Gas Valve Body
5	9151123-04	9151123-04	9151123-04	Hot Gas Valve Coil
6	9041098-01	9041098-01	9041098-01	High Temperature Safety Control
7	9151060-01	9151060-01	9151060-01	Receiver
8	9051154-14	9051154-14	9051154-14	Evaporator Splash Curtain
9	3013315-01	3013315-01	3013315-01	Ice Deflector
10	9051237-02	9051237-02	9051237-02	Washer Tube
11	2051237-81	2051237-81	2051237-81	Evaporator Right Side Full Cube
11	2051237-82	2051237-82	2051237-82	Evaporator Right Side Half Cube
12	2051238-81	2051238-81	2051238-81	Evapoartor Left Side Full Cube
12	2051238-82	2051238-82	2051238-82	Evapoartor Left Side Half Cube
13	9051540-03	9051540-03	9051540-03	Evaporator Left Side Mounting Panel
14	9051540-04	9051540-04	9051540-04	Evaporator Right Side Mounting Panel
15	9051135-04	9051135-04	9051135-04	Water Return
16	9051135-05	9051135-05	9051135-05	Spillway
17	9091086-02	9091086-02	9091086-02	Valve Core
18	9091086-03	9091086-03	9091086-03	Valve Cap
19	9101124-02	9101124-02	9101124-02	Bin Switch Right Side (Cut Arm)
20	9101124-02	9101124-02	9101124-02	Bin Switch Left Side (Cut Arm)
21	9091143-02	9091143-02	9091143-02	Remote Shut-Off Valve (Large)
	9091143-01	9091143-01	9091143-01	Remote Shut-Off Valve (Small)
22	3013316-01	3013316-01	3013316-01	Rear Brace
23	9041091-01	9041091-01	9041091-01	High Pressure Control
24	9041092-02	9041092-02	9041092-02	Pump Down Control
25	9151123-02	9151123-02	9151123-02	Liquid Line Solenoid
	9091001-12	9091001-12	9091001-12	1/2 Inch Coupling (Not Shown)
	9091001-11	9091001-11	9091001-11	3/8 Inch Coupling (Not Shown)
	9151139-01	9151139-01	9151139-01	Check Valve (Not Shown)

* Note ICE1406 Remote Cooled Compressor 9181111-11 is NLA, Reference Service Bulletin 12-08

* Note ICE1405 Remote Cooled Compressor 9181094-12 is NLA, Reference Service Bulletin 12-16

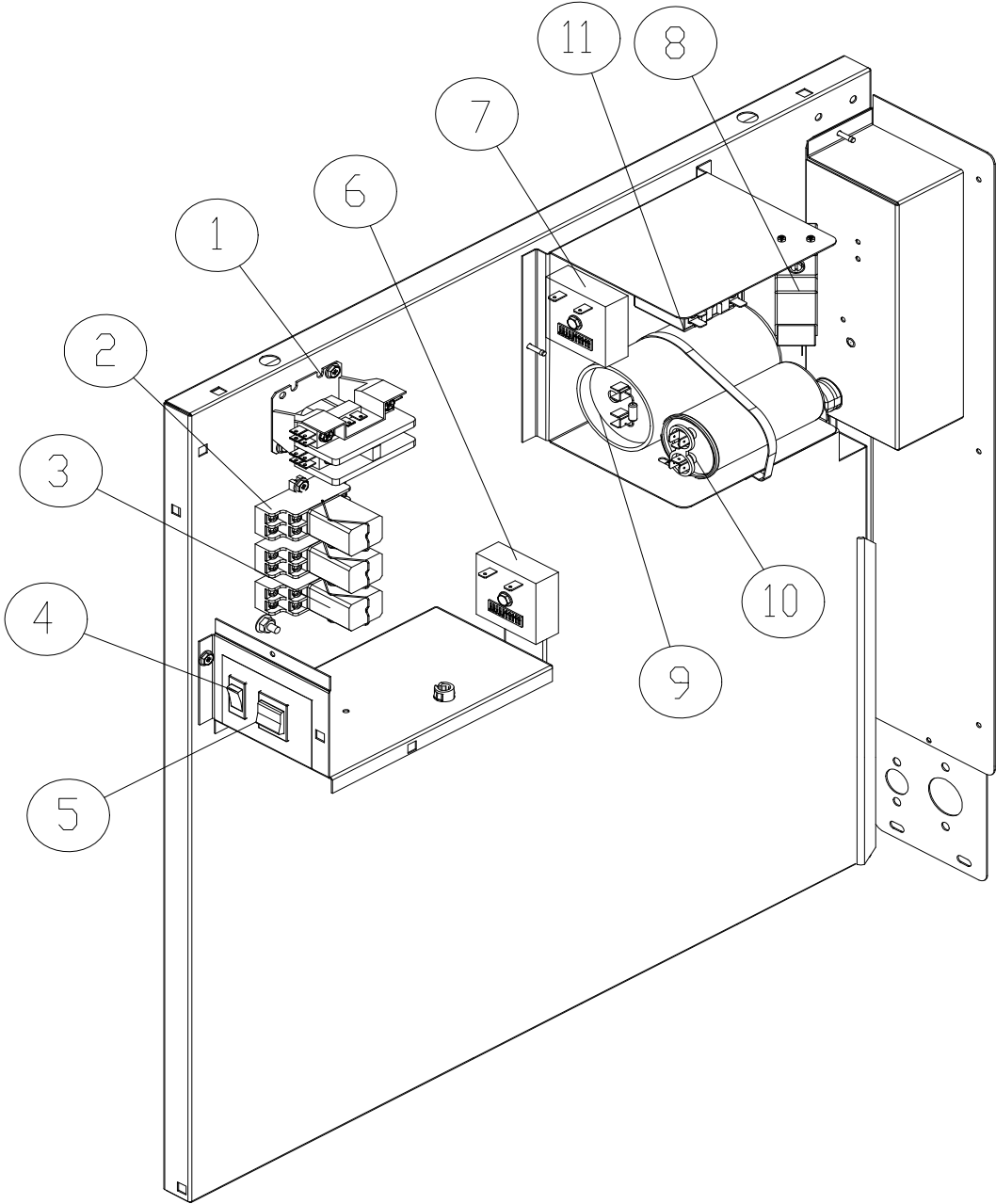

Item No.	Model Number			Description
	ICE1406	ICE1405	ICE1407	
1	9101002-06	9101002-06	9101079-02	Contactator
2	9101083-01	9101083-01	9101083-01	Relay Base
3	9101084-02	9101084-02	9101084-02	Relay
4	9101139-03	9101139-03	9101139-03	Purge Switch
5	9101195-01	9101195-01	9101195-01	ICE-OFF-WASH Switch
6	9101148-01	9101148-01	9101148-01	Timer
7	9101148-01	9101148-01	9101148-01	Timer (6 Minute-Remote only)
8	9041094-01	9041094-01	9041094-01	Low Pressure Control (Timer Initiate)
9	See Below	See Below	N/A	Start Capacitor
10	See Below	See Below	N/A	Run Capacitor
11	See Below	See Below	N/A	Compressor Relay

ICE1406	ICE1405	ICE1407	Description
9181111-11	9181094-12	9181111-12	Compressor Kit
9181003-19	9181003-34	N/A	Start Capacitor
9181009-12	9181009-20	N/A	Run Capacitor
9181010-10	9181010-04	N/A	Relay

Reference the compressor model number to insure the correct starting components are ordered.			
9181111-11			CS18K6E-PFV-235
	9181094-12		CS20K6E-PFZ-235
		9181111-12	

The following compressors are no longer available and have been replaced with the compressor kits below.			
9181111-11			9181142-11 CS18K6E-PFV-255
	9181094-12		9181143-12 CS20K6E-PFZ-255
		9181111-12	Pending

Reference the compressor model number to insure the correct starting components are ordered.			
ICE1406	ICE1405	ICE1407	Description
9181142-11	9181143-12	Pending	Compressor Kit
9181003-19	9181003-34	N/A	Start Capacitor
9181009-12	9181009-20	N/A	Run Capacitor
9181010-10	9181010-04	N/A	Relay

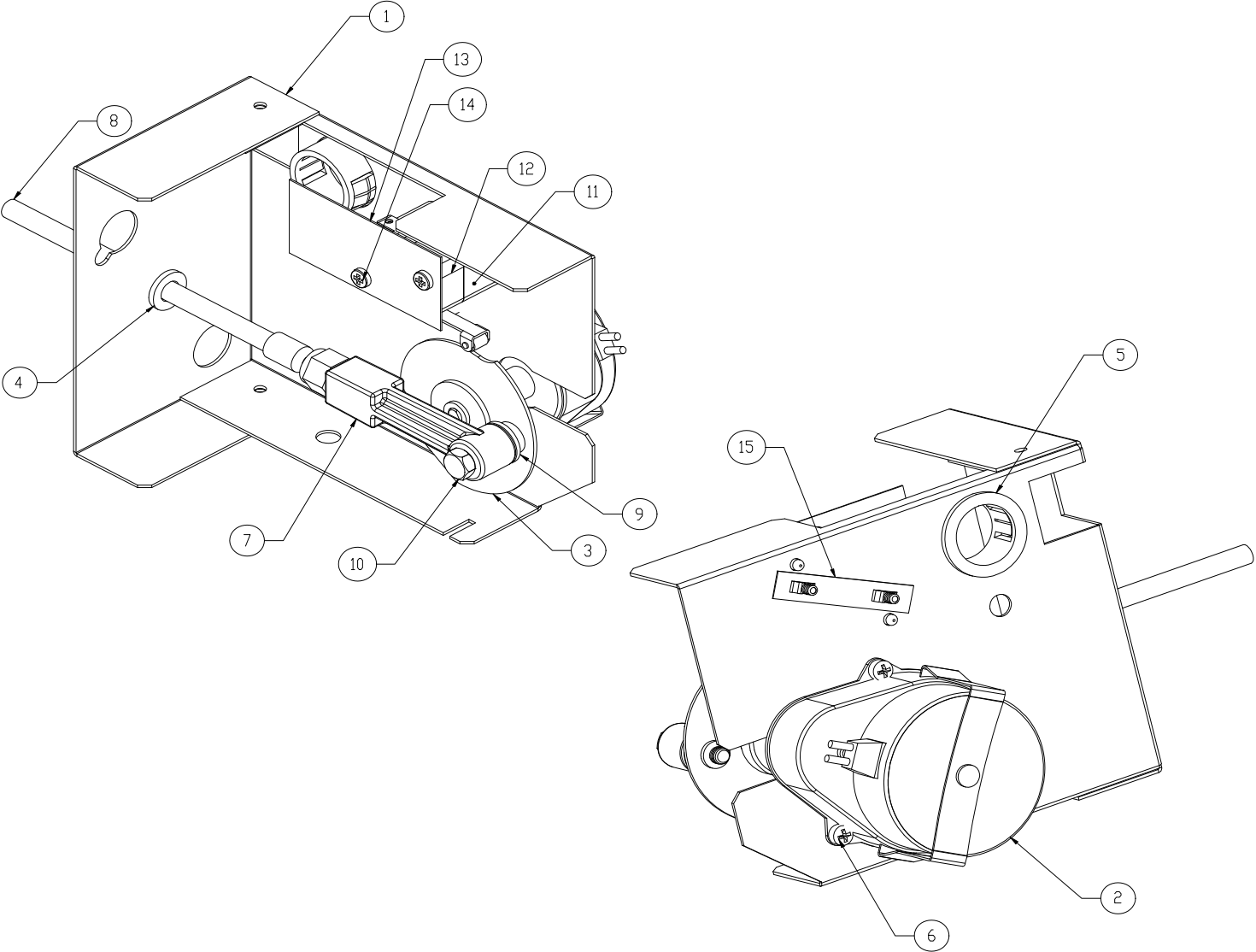

LEFT SIDE HARVIST ASSIST (SECONDARY)

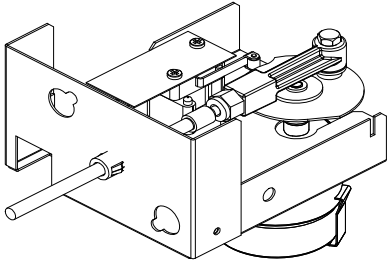
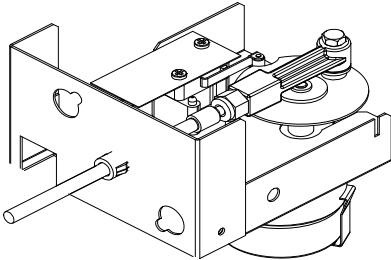

RIGHT SIDE HARVEST ASSIST (PRIMARY)

Item No.	Model Number			Description
	ICE1406	ICE1405	ICE1407	
1	3013170-01	3013170-01	3013170-01	Bracket, Probe Motor
2	9161031-01	9161031-01	9161031-01	Gear Motor
3	9131190-01	9131190-01	9131190-01	Clutch Assembly 160 Degree Cam, Right Side
	9131474-01	9131474-01	9131474-01	Clutch Assembly 160 Cam, Right Side Remote Only
	9131190-04	9131190-04	9131190-04	Clutch Assembly .312R Cam, Left Side
4	9051001-13	9051001-13	9051001-13	Snap Bushing
5	9051001-03	9051001-03	9051001-03	Snap Bushing
6	9031019-08	9031019-08	9031019-08	#6-32 x 1/2 Fillister Head Screw
7	9051057-01	9051057-01	9051057-01	Connecting Rod
8	9021102-01	9021102-01	9021102-01	Probe, Single Length
9	9031003-03	9031003-03	9031003-03	Plain Flat Washer
10	9031119-01	9031119-01	9031119-01	Shoulder Screw
11	9051519-01	9051519-01	9051519-01	Spacer, Cam Switch
12	9101160-01	9101160-01	9101160-01	Cam Switch
13	3051145-02	3051145-02	3051145-02	Insulator, Switch
14	9031008-44	9031008-44	9031008-44	Pan Head Machine Screw
15	9031120-01	9031120-01	9031120-01	Speed Nut Plate
14	2061962-02S	2061962-02S	2061962-02S	Complete Assembly-Primary- Right Side
	2061962-10S	2061962-10S	2061962-10S	Complete Assembly-Secondary- Right Side Remote Only
15	2061962-03S	2061962-03S	2061962-03S	Complete Assembly-Secondary- Left Side

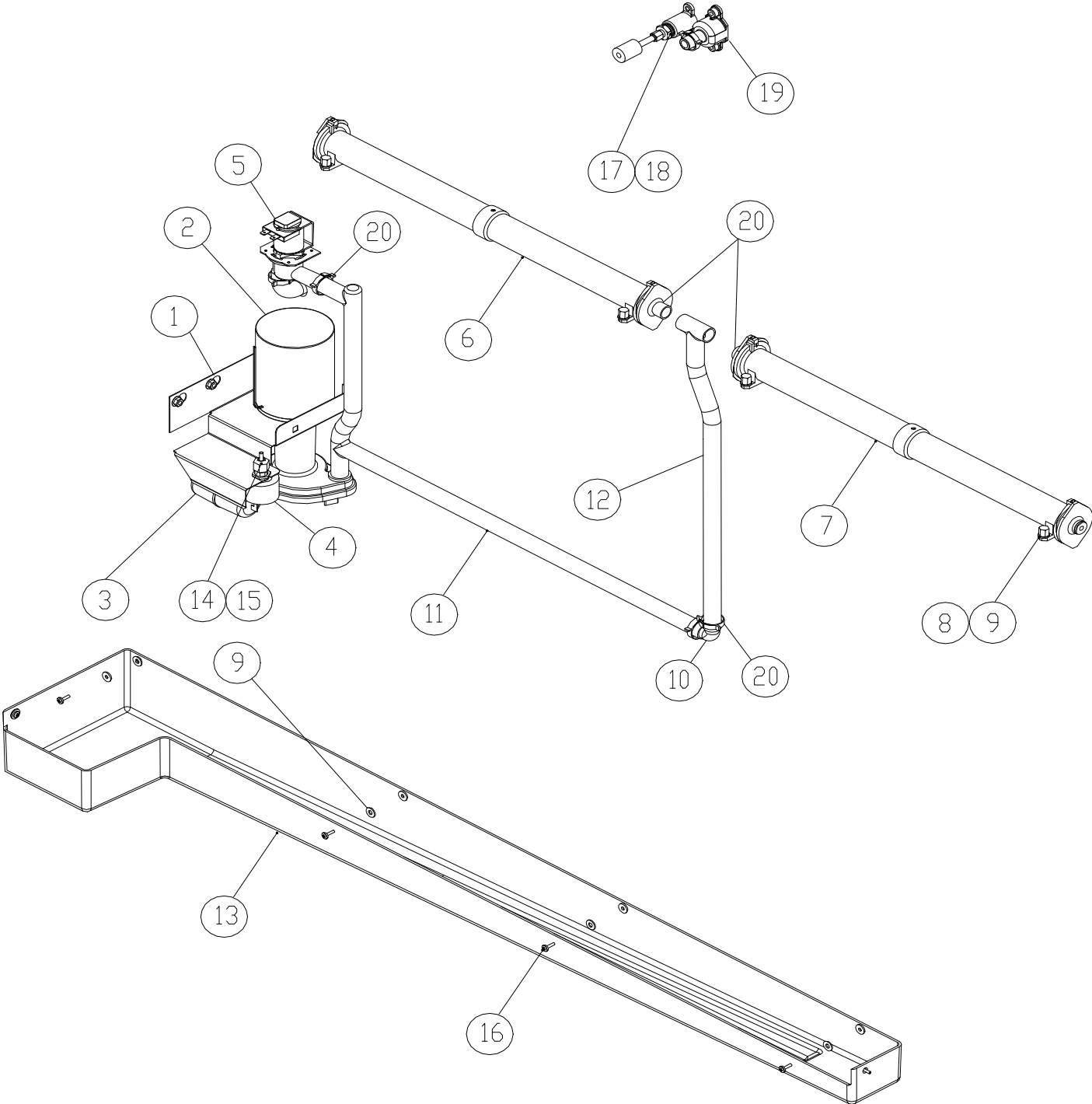

Item No.	Model Number			Description
	ICE1406	ICE1405	ICE1407	
1	3013310-01	3013310-01	3013310-01	Water Pump Bracket
2	9161079-06	9161079-06	9161079-06	Water Pump
3	9131111-02	9131111-02	9131111-02	Float
4	9131026-02	9131026-02	9131026-02	Float Deflector
5	9041086-03	9041086-03	9041086-03	Purge Valve
6	2041338-02	2041338-02	2041338-02	Water Distribution Tube Left
7	2041338-01	2041338-01	2041338-01	Water Distribution Tube Right
8	9031122-01	9031122-01	9031122-01	Thumb Screw
9	9031004-19	9031004-19	9031004-19	Washer
10	9091052-01	9091052-01	9091052-01	Elbow
11	9051543-01	9051543-01	9051543-01	Water Pump Tube (Water Pump/Purge Valve)
12	9051546-01	9051546-01	9051546-01	Water Pump Tube (Water Distribution Tube)
13	9051544-01	9051544-01	9051544-01	Water Trough
14	3032898-26	3032898-26	3032898-26	Water Inlet Tubing (34.00 inches long)
15	9091081-01	9091081-01	9091081-01	Sleeve
	9091080-01	9091080-01	9091080-01	Barrel Fitting
16	9031046-24	9031046-24	9031046-24	Water Trough Screw
17	9091074-01	9091074-01	9091074-01	Drap Adapter
18	9091083-01	9091083-01	9091083-01	Water Inlet Fitting
19	9091140-01	9091140-01	9091140-01	Drain Fitting
20	9021010-04	9021010-04	9021010-04	Clamp

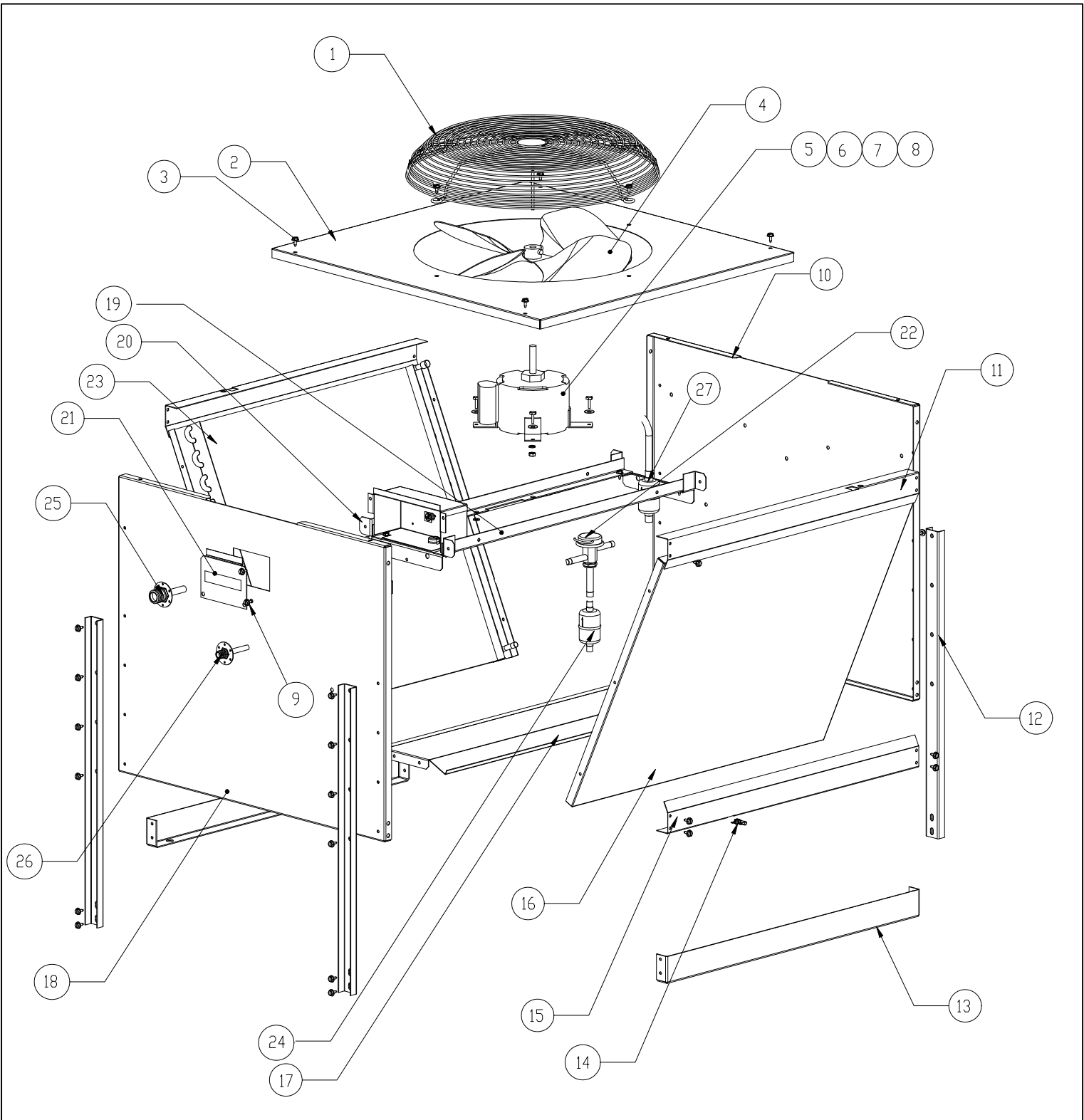

ICE0500R	ICE0600R	ICE0800R ICE1000R	ICE1400R4 ICE1506R3	ICE1800R4 ICE2100R4
----------	----------	----------------------	------------------------	------------------------

Item	VRC1001	VRC1061	VRC2061	VRC2661	VRC5061	Description
1	9131452-01	9131452-01	9131452-01	9131452-01	9131460-01	Fan Guard
2	3013222-01	3013222-01	3013222-01	3013222-01	3013303-01	Top Panel
3	9031019-04	9031019-04	9031019-04	9031019-04	9031019-04	¼-20 x 1/2 Screw
4	9131451-01	9131451-01	9131451-01	9131451-01	9131461-01	Fan Blade
5	9161117-02	9161117-01	9161117-01	9161117-01	9161118-01	Fan Motor
6	9031001-02	9031001-02	9031001-02	9031001-02	9031001-02	¼-20 x ¾ Cap Screw
7	9031003-01	9031003-01	9031003-01	9031003-01	9031003-01	Flat Washer
8	9031118-02	9031118-02	9031118-02	9031118-02	9031118-02	Flanged Lock Nut
9	9031019-04	9031019-04	9031019-04	9031019-04	9031019-04	¼-20 x 1/2 Screw
10	3013224-01	3013224-01	3013224-01	3013224-01	3013224-01	Rear Panel
11	3013226-01	3013226-01	3013226-01	3013226-01	3013305-01	Brace
12	3013227-01	3013227-01	3013227-01	3013227-01	3013227-01	Leg
13	3013228-01	3013228-01	3013228-01	3013228-01	3013306-01	Leg Brace
14	N/A	N/A	N/A	N/A	N/A	T-Nut-Shipping Only
15	3013226-01	3013226-01	3013226-01	3013226-01	3013305-01	Brace
16	3013232-01	3013232-01	N/A	N/A	N/A	Cover Panel
17	3013225-01	3013225-01	3013225-01	3013225-01	3013304-01	Center Panel
18	3013223-01	3013223-01	3013223-01	3013223-01	3013223-01	Front Panel
19	3013234-01	3013234-01	3013234-01	3013234-01	3013307-01	Motor Brace
20	3013233-01	3013233-01	3013233-01	3013233-01	3013233-01	Motor Brace Support
21	3013229-01	3013229-01	3013229-01	3013229-01	3013229-01	Junction Box Cover
22	9151027-07	9151027-06	9151027-07	9151027-07	9151027-07	Mixing Valve
23	9141135-01	9141135-01	9141135-01	9141136-01	9141137-01	Condenser
24	9151143-01	9151143-01	9151143-01	9151143-01	9151143-01	Filter
25	9091001-12	9091001-12	9091001-12	9091001-12	9091001-12	1/2 Coupling
26	9091001-11	9091001-11	9091001-11	9091001-11	9091001-11	3/8 Coupling
27	9151143-02	9151143-02	9151143-02	9151143-02	9151143-02	Filter