



GEMD270A2 PEARL-ICE ICE/WATER DISPENSER

MODELS- GEMD270A2



Installation and Service Manual

Ice-O-Matic
11100 E. 45th Ave.
Denver, Colorado 80239
1-866-PURE-ICE

Part Number
9081407-01 Revision
03/23/21

INTRODUCTION

This manual provides the specifications and the step-by-step procedures for the installation, start-up, operation, maintenance and cleaning for the Ice-O-Matic GEMD270A counter top Pearl Ice® dispenser.

Ice-O-Matic
11100 East 45th Ave.
Denver CO 80239
800-423-3367

NOTE: To retain the safety and performance built into this ice machine, it is important that installation and maintenance be conducted in the manner outlined in this manual.

Table of Contents

SPECIFICATIONS	Page 2
CABINET DIAGRAMS	Page 3
GENERAL INFORMATION AND INSTALLATION	Page 4
ELECTRICAL CONNECTIONS	Page 5
WATER SUPPLY AND DRAIN CONNECTIONS	Page 6
FINAL CHECK LIST	Page 7
OPERATING INSTRUCTIONS	Page 8
INITIAL START UP CONTINUED	Page 9
SETTING THE DISPENSING SELECTOR	Page 11
PRINCIPLE OF OPERATION	Page 12
REFRIGERANT CIRCUIT	Page 13
MECHANICAL SYSTEM	Page 14
COMPONENT DESCRIPTION	Page 15
COMPONENT DESCRIPTION	Page 16
COMPONENT DESCRIPTION	Page 17
COMPONENT DESCRIPTION	Page 18
SERVICE DIAGNOSIS	Page 19
SERVICE DIAGNOSIS	Page 20
MAINTENANCE AND CLEANING INSTRUCTION	Page 21
CLEANING INSTRUCTIONS OF WATER SYSTEM	Page 22
REMOVAL AND REPLACEMENT	Page 23
TOP BEARING REPLACEMENT	Page 24
BEARING REPLACEMENT - CONTINUED	Page 25
WATER SEAL	Page 26

GEMD270A

SPECIFICATIONS

GEMD270A:

Ice Maker Dispenser, TouchFree, 200 lb ice making capacity, Pearl Ice ®, 12 lb storage

To keep your Ice-O-Matic Pearl Ice ® Dispenser at peak performance levels, periodic maintenance checks must be carried out as indicated in this manual.

Important Operating Requirements:

	Min	Max
Air Temperature	50°F	100°F
Water Temperature	40°F	95°F
Water Pressure	20 psi	70 psi
Electrical voltage variations from voltage rating specified on nameplate	-10%	+10%

MACHINE SPECIFICATIONS

Model	Cond. unit	Cabinet Size	Finish	Comp. HP	Ice bin cap
GEMD270A	Air	34 13/32" high x 15 9/32" wide x 26 7/64" deep	S. Steel	3/8	12 lb.

Basic electrical	Amps	Watts	Amps fuse
115/60/1	6	550	15

Unit is equipped with leveling legs.

The unit has a power cord.

CABINET DIAGRAMS

SPECIFICATIONS

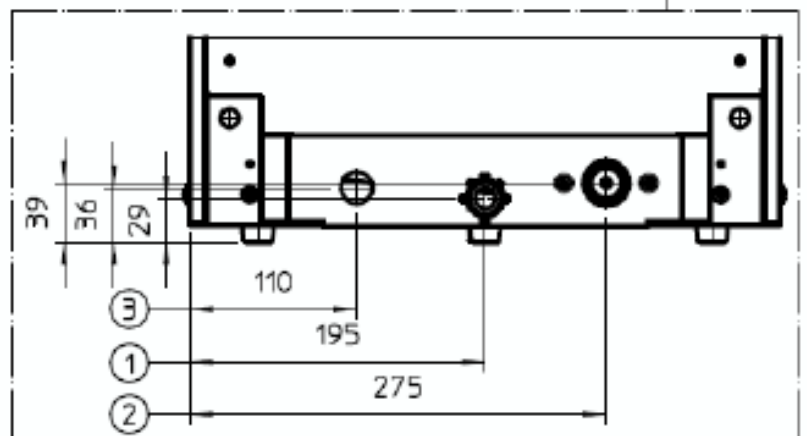
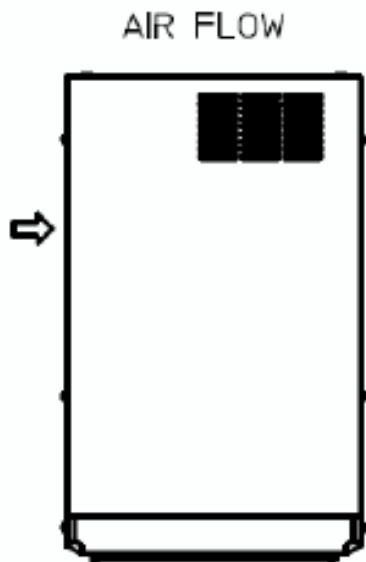
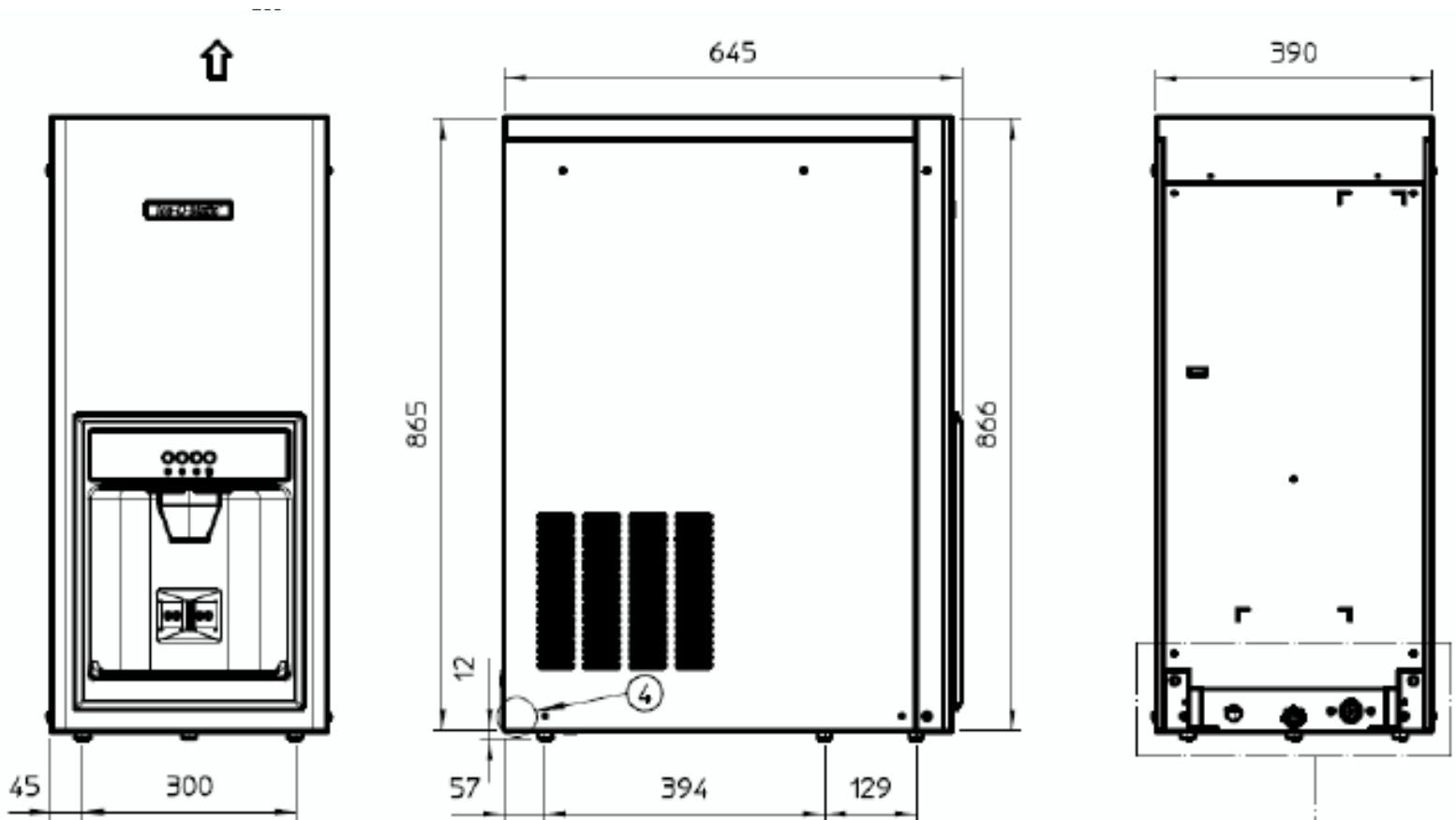

UNIT OF MEASURE: mm

1. \varnothing 20 mm DRAIN WATER
2. 3/4" GAS - WATER INLET
3. POWER CORD
4. CONCEALED CONNECTIONS

GEMD270A

GENERAL INFORMATION AND INSTALLATION

UNPACKING AND INSPECTION

1. Call your authorized Ice-O-Matic Distributor or Dealer for proper installation.
2. Visually inspect the exterior of the packing and skid. Any severe damage noted should be reported to the delivering carrier and a concealed damage claim form filled in subject to inspection of the contents with the carrier's representative present.
3. a) Cut and remove the plastic strip securing the carton box to the skid.
b) Cut open the top of the carton and remove the polystyrene protection sheet.
c) Pull out the polystyrene posts from the corners and then remove the carton.
4. Remove the top and sides panels of the unit and inspect for any concealed damage. Notify carrier of your claim for the concealed damage as stated in step 2 above.
5. Remove all internal support packing and masking tape.
6. Check that refrigerant lines do not rub against or touch other lines or surfaces, and that the fan blades move freely.
7. Check that the compressor fits snugly onto all its mounting pads.
8. Use clean damp cloth to wipe the surfaces outside of the cabinet.
9. See data plate on the rear side of the unit and check that local main voltage corresponds with the voltage specified on it.
CAUTION: Incorrect voltage supplied to the ice machine will void your parts replacement program.
10. Remove the manufacturer's registration card from the inside of the Users Manual and fill-in all parts including Model and Serial Number taken from the data plate. Forward the completed self-addressed registration card to Ice-O-Matic factory.

LOCATION AND LEVELING

WARNING: This Ice Dispenser is designed for indoor installation only. If the machine is operated for extended periods at temperatures exceeding the following limitations it will constitute misuse under the terms of the Ice-O-Matic Manufacturer's Limited Warranty resulting in LOSS of warranty coverage.

Position the unit in the selected permanent location. Criteria for selection of location include:

	Min	Max
Air Temperature	50°F	100°F
Water Temperature	40°F	95°F
Water Pressure	20 psi	70 psi
Electrical voltage	103 v	126 v

Service access: adequate space must be left for all service connections through the rear of the ice machine.

This machine is air-cooled and sucks air through the left side panel and blows air out the rear side of the top panel. Do not install the machine where the left and upper rear side air flows might be blocked.

A minimum clearance of 6 inches is required at the left and upper rear side for air circulation.

It is important that the machine be installed in a location where it has enough space around it to be accessible for service. Avoid hot, dirty and crowded locations.

NOTE: Do NOT place anything on top of the machine. Leave the upper louvers open for proper air exhaust.

The base of the GEMD270A must be sealed to the counter top.

1. Place the unit in its final position.
2. Place a bead of sealant on the counter top to match the outside edge of the cabinet base and sink.

Food grade silastic sealant is recommended.

ELECTRICAL CONNECTIONS

See data plate for current requirements to determine wire size to be used for electrical connections. All Ice-O-Matic ice machines require a solid earth wire. This Ice-O-Matic ice machine is supplied from the factory completely pre-wired and only needs to be plugged into a nearby 115 volt outlet.

Make sure that the ice machine is connected to its own circuit and individually fused (see data plate for fuse size). Not Connected to a G.F.I. outlet

The maximum allowable voltage variation should not exceed -10% and +10% of the data plate rating. Low voltage can cause faulty functioning and may be responsible for serious damage to the overload switch and motor windings.

NOTE: All external wiring should conform to national, state and local standards and regulations.

Check voltage on the line and the ice machine's data plate before connecting the unit.

GEMD270A

WATER SUPPLY AND DRAIN CONNECTIONS

GENERAL

When choosing the water supply for the ice flaker, consideration should be given to:

- a) Length of run
- b) Water clarity and purity
- c) Adequate water supply pressure

Water is the most important single ingredient in producing ice - these three items are very important.

Low water pressure, below 20 psi may cause malfunction of the ice machine unit.

Water containing excessive minerals will tend to produce scale build-up on the interior parts of the water system while water that's too soft (water contains too few mineral salts), will produce a very hard flaked ice.

PLUMBING CONNECTIONS MUST CONFORM TO ALL APPLICABLE CODES

CONNECT TO POTABLE WATER ONLY

The model GEMD270A is capable of having water connections through the bottom base or through the rear bottom side of the machine. In this second case it is necessary to remove the small panel at the bottom rear.

WATER SUPPLY

Connect to the 3/4" male water inlet fitting, using the supplied fitting, to the cold water supply line. A shut-off valve should be installed in an accessible position between the water supply line and the unit.

If the water contains a high level of impurities, consider installing a water filter or conditioner.

WATER DRAIN

The recommended drain tube is a copper, rigid plastic or reinforced flexible tubing (supplied) with .75" (19mm) I.D. which runs to an open trapped and vented drain. When the drain is a long run, allow 1/4" drop per foot.

Note: Although soft, easily kinked vinyl tubing is not recommended for a drain, a short length of 3/4" ID vinyl tubing is required to connect a rigid drain tube to the 20 mm (25/32") fitting on the back of the GEMD270A.

Install a vertical open vent on the drain line high point at the drain connection to ensure good draining.

The ideal drain receptacle is a trapped and vented floor drain.

NOTE: The water supply and the water drain must be installed to conform with the local code. In some case a licensed plumber and/or a plumbing permit is required.

FINAL CHECK LIST

1. Is the unit in a room where the ambient temperatures are within a minimum of 50°F even in winter months?
2. Is there at least a 6" clearance around the unit for proper air circulation?
3. Is the unit level?
4. Have all the electrical and plumbing connections been made, and is the water supply shut-off valve open?
5. Has the voltage been tested and checked against the data plate rating?
6. Has the water supply pressure been checked to ensure a flowing water pressure of at least 20 psi.
7. Check all refrigerant lines and conduit lines to guard against vibrations and possible failure.
8. Has the unit been sealed to the counter top?
9. Has the owner/user been given the Users Manual and been instructed on the importance of periodic maintenance checks?
10. Has the Manufacturer's registration card been filled in properly? Check the model and serial number against the serial plate and mail the registration card to Ice-O-Matic.
11. Has the owner been given the name and the phone number of the authorized Ice-O-Matic Service Agency serving them?

OPERATING INSTRUCTIONS

START UP

After having correctly installed the ice maker and completed the plumbing and electrical connections, perform the following “Start-up” procedure.

A. Open the water supply line shutoff valve and give power by moving the main switch, on the power supply line, to the ON position. The **GREEN LED** will glow to signal that unit is under power.

NOTE. Everytime the unit is put under power, after being kept for sometime in shut-off conditions (electrically disconnected) the 2nd RED LED will blink for 3 minutes (Fig.1).

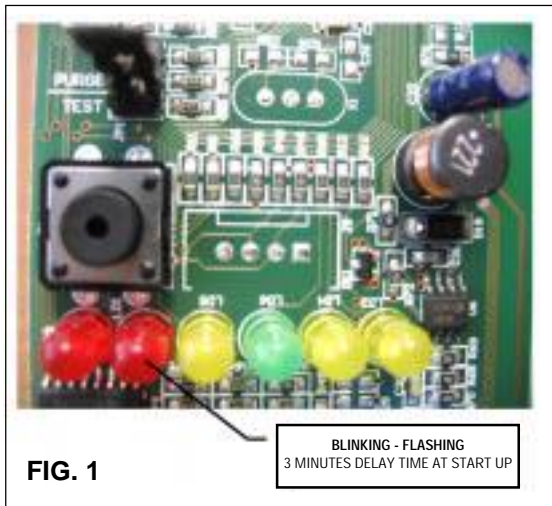

B. Elapsed the 3 minutes - stand by period - the unit starts operating with the activation in sequence of the following assemblies:

GEAR MOTOR

COMPRESSOR

FAN MOTOR kept under control by the condenser temperature sensor which has its probe within the condenser fins with the switching off of the 2nd RED LED (Fig. 2).

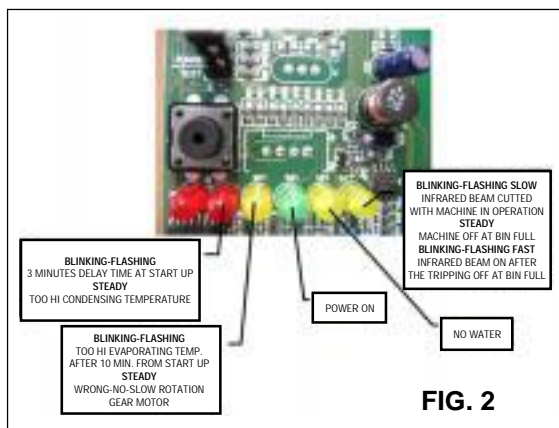

C. 2 or 3 minutes after the compressor start up, observe that flaker ice begins dropping off the ice spout to fall into the storage bin.

NOTE. If, after ten minutes from the compressor start-up, the evaporating temperature has not dropped down to a value lower than -1°C (30°F) the evaporating temperature sensor detects such an abnormal situation and stops consequently the unit operation.

In this circumstance, the 3rd warning **YELLOW LED** will blink (Fig.3).

After having diagnosed and eliminated the cause of the poor evaporating temperature (insufficient refrigerant in the system or inoperative compressor or evaporator sensor) it is necessary to push the **RE-SET BUTTON** or De-engerize and re-engerize unit. The unit, before resuming the total operation, will go through the usual 3 minutes **STAND-BY** period.

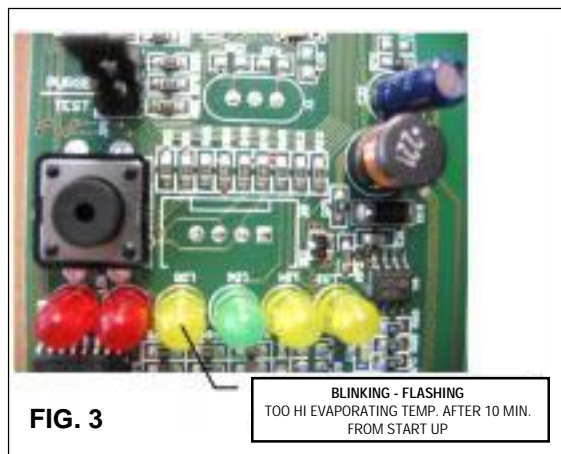

OPERATION CHECKS UPON THE UNIT START UP

D. Remove service panels and if necessary install the refrigerant service gauges on the corresponding Service valves to check both the HI and LO refrigerant pressures.

NOTE. The condenser temperature sensor, which is located within the condenser fins, keeps the head (condensing) pressure between two preset valves.

In case of condenser clogging such to prevent the proper flow of the cooling air or, in case the fan motor is out of operation, the condenser temperature rises and when it reaches 70°C (160°F) the condenser temperature sensor shuts-off the ice maker with the consequent light-up of the 2nd **RED WARNING LIGHT** (Fig.4).

After having diagnosed the reason of the temperature rise and removed its cause, it is necessary to proceed as per the previous “NOTE” to start up again the operation of the ice maker.

OPERATING INSTRUCTIONS

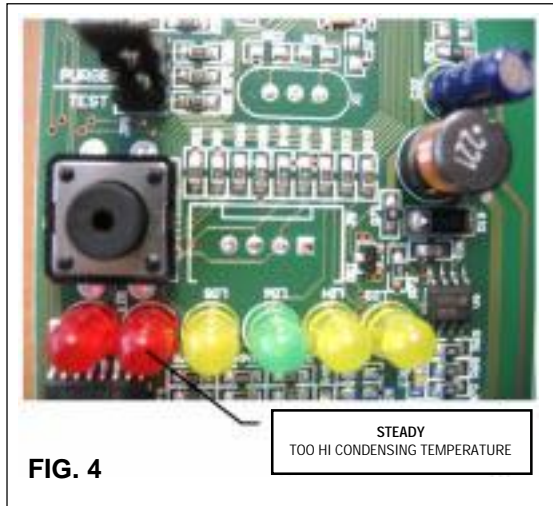

E. Check for the correct CUT-OUT and CUT-IN of the **float reservoir water level sensors** by shutoff the valve on the water supply line.

This will cause a gradual decrease of the water level in the float reservoir and as soon as the level gets below the sensors, the flaker stops to operate and the **5th YELLOW warning LED** will glow to signal the shortage of water (Fig.5).

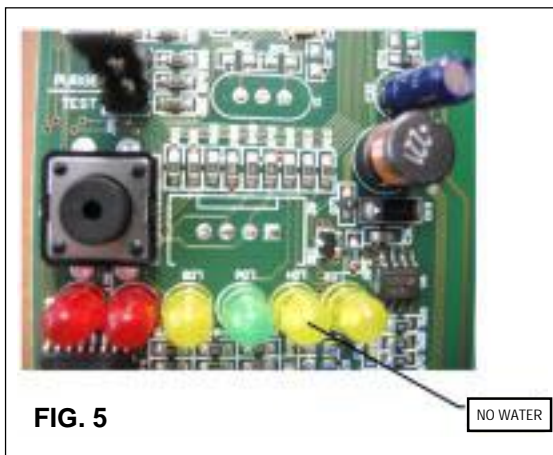

NOTE. The water level sensor detects the presence of sufficient water in the float reservoir and confirms it to the micro processor by maintaining a low voltage current flow between the two sensors using the water as conductor.

WARNING. The use of de-mineralized water (water with no salt content) having an electrical conductivity lower than 30 μ S, will cause the ability of the water sensors to vanish with the consequent CUT-OUT of the flaker operations and the glowing of the YELLOW LED of shortage of water, even though that water is indeed in the reservoir.

After this, open the water supply line shutoff valve to fill up again the float reservoir, the **5th YELLOW LED** goes off while the **2nd RED LED** starts blinking.

After 3 minutes the unit resumes its total operation with the immediate start-up of the gear motor and, 2 seconds later, of the compressor.

F. Check for the correct operation of the electronic eye for the ice bin level control, by placing one hand between the sensing "eyes" located in the ice spout, to interrupt the light beam.

This interruption will cause an immediate blink of the **6th YELLOW LED** and after about 6 seconds causes the shutoff of the unit with the simultaneous lighting of the **same YELLOW LED** signalling the **full bin situation** (Fig.6).

Allow the resumption of the light beam previously interrupted and after about 6 seconds with YELLOW LED blinking fast, the flaker will resume - through the 3 minutes STAND-BY period - the ice making process with the extinguishing of the YELLOW LED.

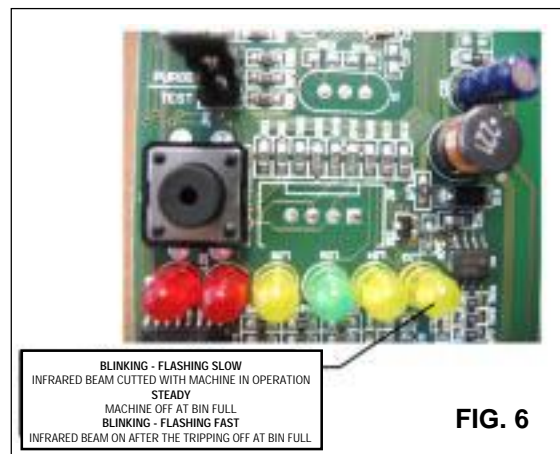

NOTE. The **ICE LEVEL CONTROL (INFRA-RED SYSTEM)** is independent of the temperature however, the reliability of its detection can be affected by dirt and scale sediment which may deposit directly on the light source and on the receiver.
To prevent any possible ice maker malfunction, due to negative affection of the light detector, it is advisable to follow the instructions for the **periodical cleaning of the light sensor** elements as detailed in the **MAINTENANCE AND CLEANING PROCEDURES.**

PRINCIPLE OF OPERATION

WATER CIRCUIT

The water enters in the machine through the water inlet fitting (which incorporates a strainer and it is located at the rear side of the cabinet) and then it goes to the water reservoir flowing through a float valve.

NOTE. *The presence of the water in the float reservoir is detected by a system of two sensors which operates in conjunction with the P.C. Board. The two sensors use the water as a conductor to maintain a low voltage current flow between them. In case the water used is very soft (de-mineralized) or the reservoir is empty the current flow between the sensors become so weak or is no longer there that, as consequence, the P.C. Board shutoff the flaker operation with the simultaneous glowing of the **YELLOW LED** signalling "Shortage of water".*

The float reservoir is positioned at the side of the freezing cylinder at such a height to be able to maintain a constant water level around the freezer auger. In fact, the water flows from the reservoir into the bottom inlet of the freezing cylinder to surround the stainless steel auger which is vertically fitted in the center of the freezer. In the freezer the incoming water gets chilled into soft (slush) ice which is moved upward by the rotating action of the auger. The stainless steel auger that rotates counter-clockwise within the freezer, is powered by a direct drive gear motor and carries the ice upward along the refrigerated freezer inner walls and by doing so the ice gets progressively thicker and harder.

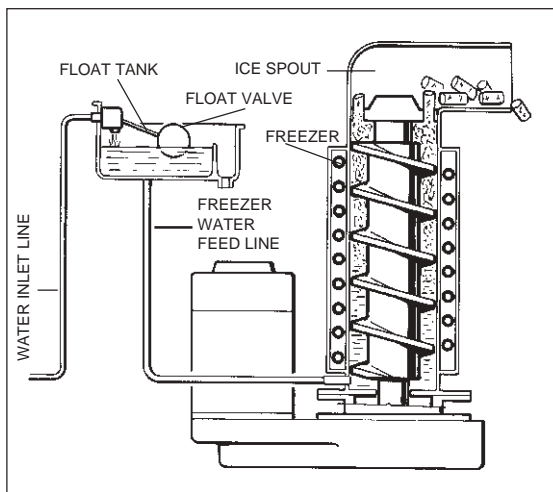

The ice, being constantly lifted up, meet the tooth of the ice breaker which is fitted on the top end of the auger, where it gets compacted, cracked and forced to change from vertical into horizontal motion to be discharged out, through the ice spout, into the storage bin. By running the ice maker, i.e. by putting the unit under power, starts the automatic and continuous icemaking process which would not stop until the

ice storage bin gets filled-up to the level of the control "eyes" located on the sides of the ice spout. As the ice level raises to interrupt the light beam running between the two infrared lamps, the unit stops after six seconds, with the simultaneous glowing of the **YELLOW LED** signalling the "**Full Bin**" situation.

NOTE. *The interruption of the light beam between the two light sensors is immediately signalled by the blinking of the **6th YELLOW LED** located on the front of the P.C. Board. After about **6" of steady interruption** of the light beam the unit stops and the "**Full Bin**" **YELLOW LED** glows. The six seconds of delay prevent the unit from stopping for any undue reason like the momentarily interruption of the light beam caused by the flakes that slides along the ice spout before dropping into the bin.*

As some ice is dispensed from the storage bin, the light beam between the two sensors resumes and immediately the **6th YELLOW LED** blinks fast; six seconds later the ice machine restarts the ice making process and the **YELLOW LED** goes off.

REFRIGERANT CIRCUIT

The hot gas refrigerant discharged out from the compressor reaches the condenser where, being cooled down, condenses into liquid. Flowing into the liquid line it passes through the drier filter, then it goes all the way through the capillary tube where it loses some of its pressure so that its pressure and temperature are lowered. Next, the refrigerant enters into the evaporator coil wrapped around the freezer inner tube. The water being constantly fed at the interior of the freezer inner tube, exchange heat with the refrigerant circulating into the evaporator coil, this cause the refrigerant to boil-off and evaporate, thereby it changes from liquid into vapor. The vapor refrigerant then passes through the suction accumulator and through the suction line where the refrigerant exchanges heat with the one flowing into the capillary tube (warmer) before being sucked into the compressor to be recirculated.

The refrigerant heat pressure is kept between two pre-set values **9÷10 bar -125÷140 psig** by the condenser temperature sensor which has its probe located within the condenser fins - in air cooled versions.

This condenser temperature sensor, when senses a rising of the condenser temperature beyond the pre-fixed limit, changes its electrical resistance and sends a low voltage power flow to the **MICRO-PROCESSOR** of the P.C. Board which energizes, through a **TRIAC**, the **Fan Motor in ON-OFF mode**.

PRINCIPLE OF OPERATION

When the opposite situation occurs, i.e. the condenser temperature gets below the pre-fixed

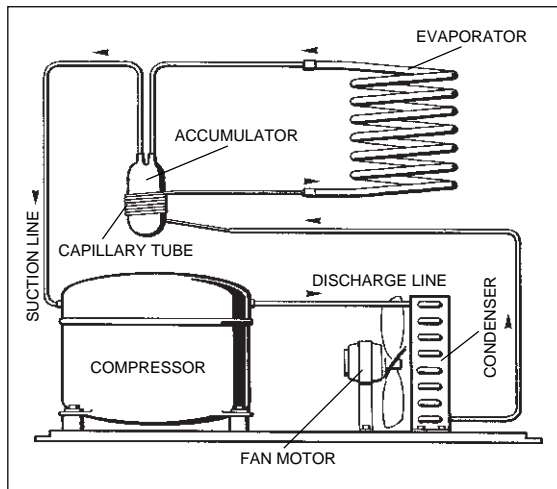

limit, the temperature sensor changes again its electrical resistance reducing therefore the current flow to the P.C. Board to cause a temporary stop of the Fan Motor.

NOTE. In case the condenser temperature probe senses that the condenser temperature has risen to **70°C (160°F)** for one of the following abnormal reasons:

CLOGGED CONDENSER
FAN MOTOR OUT OF OPERATION
AMBIENT TEMPERATURE HIGHER THEN
43°C (110°F)

it causes the total and immediate **SHUT-OFF** of the machine in order to prevent the unit from operating in abnormal and dangerous conditions. When the ice maker stops on account of this protective device, there is a simultaneous glowing of the **2nd RED LED**, warning the user of the **Hi Temperature** situation. After having eliminated the source of the excessive condenser temperature, to restart the ice machine it is necessary to push the **RE-SET** button or De-engerize and Re-engerize the unit.

The **2nd RED LED starts blinking** and three minutes later the flaker unit resume its normal operating mode.

The refrigerant suction or Low-pressure sets in normal ambient conditions (21 °C/70°F) - on the value of **1 bar (14 psig)** after few minutes from the unit start-up.

This **value can vary of 0.1 or 0.2 bar (1.5÷3 psig)** in relation to the water temperature variations influencing the freezer cylinder.

NOTE. If, after ten minutes from the unit start up, no ice is made and the evaporating temperature detected by the evaporator sensor is higher than **-1°C (30°F)** the ice maker stops and the **3RD WARNING YELLOW LED** blinks.

MECHANICAL SYSTEM

The mechanical system consists basically of a gear motor assembly which drives, through a ratched coupling, a worn shaft or auger placed on its vertical axis within the freezing cylinder.

The gear motor is made of a single phase electric motor with a permanent capacitor. This motor is directly fitted in the gear case through which it drives - in counter clockwise rotation at a speed of 9.5 r.p.m. - the freezer auger being linked to it by the ratched coupling.

NOTE. In the event the gear motor will tend to rotate in the wrong direction or not rotating at all the unit will **stop immediately** with the glowing of the **3RD WARNING YELLOW LED** on account of the intervention of the **Electromagnetic Safety Device** based on Hall Effect principle. After having diagnosed and eliminated the source of the failure, to restart the unit it is necessary to press the **RE-SET** push button or switch **OFF** and **ON** the power line main disconnect switch (Fig. 7). The **RED LED** will start blinking and after 3 minutes the ice maker will resume its total operations by running first the gear motor and then the compressor.

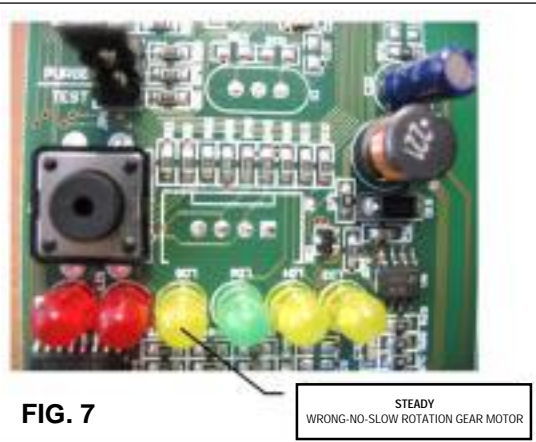

FIG. 7

When the gear motor rotating speed is slowed below **1300 r.p.m.** from the normal speed of 1400 r.p.m. the Electromagnetic Safety Device transmits an electrical signal to the MICROPROCESSOR to **stop immediately** the unit operations like it occurs for the wrong rotation, with the lighting-up of the **3RD YELLOW WARNING LED**. This to relieve from the excessive load all the electrical and mechanical components of the entire Drive System and extend their durability.

NOTE. After having diagnosed and eliminated the source of the gear motor slow rotation to restart the unit it is necessary to press the **RE-SET** push button or switch **OFF** and **ON** the power line main switch.

NOTE. Any time the machine stops in alarm the front four LED's start to blink.

PRINCIPLE OF OPERATION

REFRIGERANT METERING DEVICE:

capillary tube

OPERATING PRESSURES

(With 21°C/70°F ambient temperature)

Discharge pressure: 9 ÷ 10 bar (125 ÷ 140 psig)

Suction pressure: 1 bar (14 psig)

REFRIGERANT CHARGE (R 134 A): 370 gr

NOTE. Before charging the refrigerant system always check the type of refrigerant and quantity as specified on the individual ice machine dataplate.

The refrigerant charges indicated are relatives to averages operating conditions.

COMPONENT DESCRIPTION

A. EVAPORATOR TEMPERATURE

SENSOR - BLACK 2 POLES CONNECTOR
- MANUAL RESET (see **NOTE)

The evaporator sensor probe is inserted into its tube well, which is welded on the evaporator outlet line. It detects the temperature of the refrigerant on the way out from the evaporator and signals it by supplying a low voltage current flow to the P.C. Board Micro-Processor.

According to the current received, the micro-processor let the ice maker to continue its operations or not. In case the evaporating temperature, after 10 minutes from the unit start-up, does not go below -1°C (30°F) the evaporator sensor signal reaching the microprocessor is such to stop immediately the unit operation, with the 3rd Warning YELLOW LED that blinks.

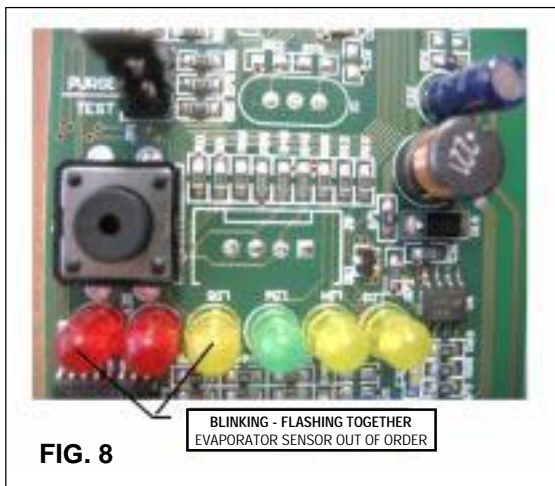

FIG. 8

B. WATER LEVEL SENSOR - RED TWO POLES CONNECTOR - AUTOMATIC RESET

This sensor system consist of two small stainless steel rods vertically fitted on the inner face of the reservoir cover and electrically connected to the low voltage circuit of the P.C. Board. When the cover of the reservoir is positioned in its place the tips of both the rods dip into the reservoir water and detects and signals its presence by supply power back to the P.C. Board.

NOTE. In the event of **shortage of water** in the reservoir or, in case the water used is too soft (de-mineralized) to cause greater resistance to the current flow (conductivity lower than $30\mu\text{S}$) this sensor system causes the **shutoff of the machine**, to protect it from running with an interrupted or inadequate water supply.
 In this situation the **5th YELLOW LED** will glow to warn of the machine shutoff and the reason why.

C. CONDENSER TEMPERATURE SENSOR - WHITE TWO POLES CONNECTOR - MANUAL RESET (see **NOTE)

The condenser temperature sensor probe, located within the condenser fins detects the condenser temperature variations and signals them by supplying current, at low voltage, to the P.C. BOARD.

In relation to the different current received, the micro processor of the P.C. BOARD supplies, through a TRIAC, the power at high voltage to the fan motor so that it can cool the condenser and reduce its temperature.

In the event the condenser temperature rises and reaches $70^{\circ}\text{C}/158^{\circ}\text{F}$ the current arriving to the micro processor is such to cause an immediate and total stop of the machine operation with the glowing of the 2nd RED WARNING LED.

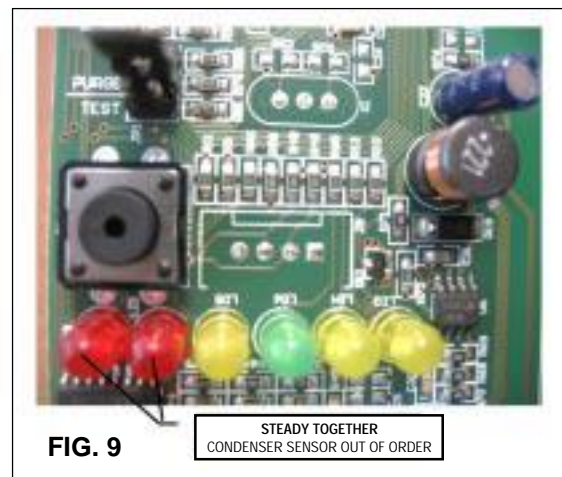

FIG. 9

****NOTE.** To restart the unit after the shutoff it is necessary to push the **RE-SET** button (after having remedied to the causes of unit stoppage) or to switch **OFF** and **ON** the power line main disconnect Switch.

D. GEAR MOTOR ROTATION AND SPEED

SENSOR - RED FOUR POLES CONNECTOR
- MANUAL RESET (see **NOTE)

This safety device is housed on top of the Drive Motor and detects - based on Hall Effect principle - the rotating speed and rotating direction of the drive Motor.

Should the rotating speed drop below 1300 r.p.m. the magnitude measured by this device is such to signal to the microprocessor to stop the unit and light-up the 3rd YELLOW LED. The same reaction occurs when the drive motor will tend to rotate in the wrong direction or it doesn't rotate at all.

NOTE. To restart the unit after the shutoff caused by this safety device, it is necessary first to eliminate the cause that has generated the intervention of the device and then press the **RE-SET** push button or switch **OFF** and **ON** the power line main disconnect switch.

COMPONENT DESCRIPTION

E. ICE BIN LEVEL LIGHT CONTROL - BLACK FOUR POLES CONNECTOR - AUTOMATIC RESET

The electronic ice bin level control, located into the ice spout, has the function to stop the operation of the ice machine when the light beam between the light source and the sensor gets interrupted by the flake ice which accumulates in the spout. When the light beam is interrupted the **6th YELLOW LED** located in the front of the P.C. BOARD blinks; in case the light beam gets interrupted for as long as 6 seconds, the ice machine stops with the glowing-up of the **same YELLOW LED** to monitor the full ice bin situation. The 6 seconds of delay prevents that any minimum interruption of the light beam due to the regular ice chuting through the ice spout may stop the operation of the unit.

As soon as the ice is dispensed out (with the resumption of the light beam between the two infrared sensor of ice level control) the YELLOW LED blinks fast and after 6 seconds the ice machine resume its operation with the simultaneous extinguishing the YELLOW LED.

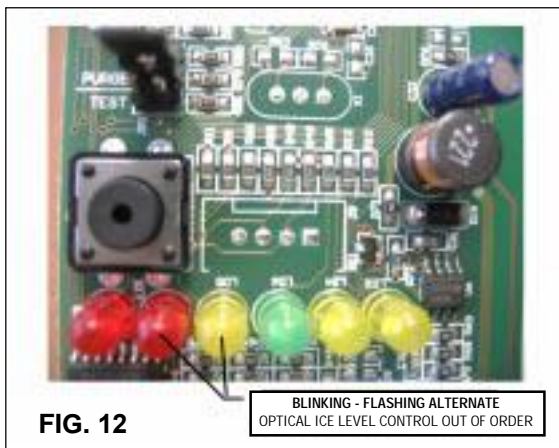

F. ICE/WATER OPTICAL DISPENSING DEVICE - BLUE FOUR POLES CONNECTOR

Located on the front of the dispensing area it consists of the combination of an infrared Transmitter and Receiver.

When a glass or a carafe is placed in front of the Infrared sources, the optical device transmits a signal to the PC Board that is equivalent to activate the dispensing drive motor which, in turn, put in rotation a dispensing vane that pushes the ice towards a rectangular opening located in the bottom of the storage bin.

Elapsed the dispensing time (5, 10 or 15 seconds according to the setting) or after removing the glass/carafe, the infrared resume its original condition switching off the dispensing drive motor.

****FIG 12. If Ice Level Sensor is out of order: Blinking Alternate between 2nd Red & 3rd Yellow lights.****

H. P.C. BOARD (Data processor)

The **P.C. BOARD**, fitted in its plastic box located in the right side of the unit, consists of two separated printed circuits one at high and the other at low voltage, protected by three fuses, integrated with a RE-SET button. Also it consists of six aligned **LEDS** monitoring the operation of the machine and of input terminals for the leads of the sensor probes as well as input and output terminals for the leads of the ice maker electrical wires. The P.C. BOARD is the brain of the system and it elaborates, through its micro processor, the signals received from the sensors in order to control the operation of the different electrical components of the ice maker (compressor, gear motor, etc.) as well as the dispensing of the ice and water.

Ref. to FIG. 10 the six LEDS from left to right:

2nd RED LED ON :

Unit shut-off due to a too hi-condensing temperature > 70°C/158°F

2nd RED LED BLINKING:

3 minutes start up delay time

3rd YELLOW LED ON:

Unit shut-off due to the wrong rotation direction of gear motor or due to the too low speed of gear motor

3rd YELLOW LED BLINKING: Unit shut-off due to high evap. temp > -1°C/30°F after 10 min of operation

COMPONENT DESCRIPTION

4th GREEN LED ON:

- Unit under electrical power

5th YELLOW LED ON:

- low water reservoir level or low/no conductivity

6th YELLOW LED ON

- Unit shut-off at storage bin full

Blinking slow

- Infrared beam cutted with machine in operation

Blinking fast

- Infrared beam ON after tripping OFF at storage bin full

BOTH RED LEDS STEADY (Fig. 11)

- Condenser sensor Out of Order

YELLOW AND RED BLINKING TOGETHER - (Fig. 11)
Evaporator sensor Out of Order

YELLOW AND RED BLINKING ALTERNATE- (Fig. 11)
Optical Ice Level Control Out of Order

- Push and hold the PC Board push button
- Switch ON the machine keeping pushed the PC Board push button till all LEDs are ON
- Release the push button

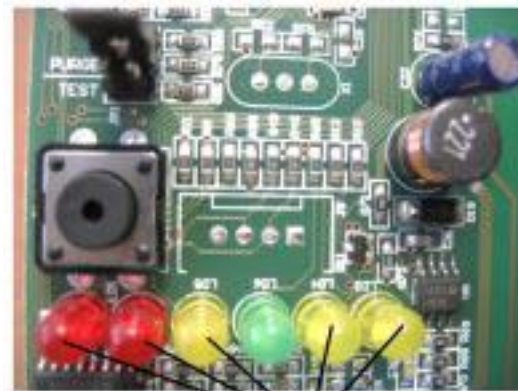

ALL STEADY
CALIBRATION OF PC BOARD &
OPTICAL ICE LEVEL CONTROL

FIG. 10

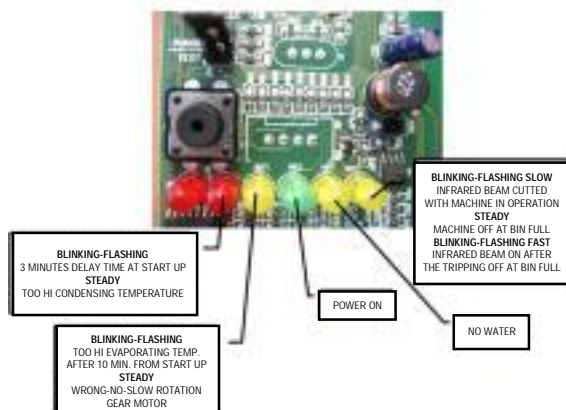
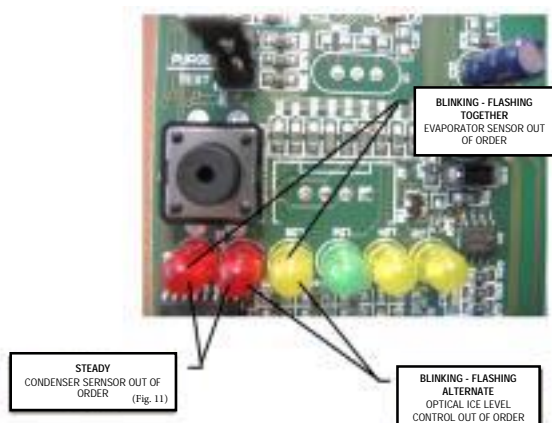

FIG. 11



CALIBRATION OF ICE LEVEL CONTROL/PC BOARD

Any time the PC Board and/or the Ice Level Control are replaced it necessary to perefom the calibration as per following instructions:

- Switch OFF the machine

I. FLOAT RESERVOIR

The float reservoir consists of a plastic water pan on which is fitted a float valve with its setting screw. The float valve modulate the incoming water flow to maintain a constant water level in the reservoir, level that corresponds to the one in the freezing cylinder to ensure proper ice formation and fluidity.

On the inner side of the reservoir cover are fitted the two water level sensors which detects the presence or the shortage of water in the reservoir.

NOTE. *It is very important to make sure of the correct fitting of the cover on the reservoir in order to enable the sensor to efficiently control the water situation avoiding undue shutoff interventions.*

J. FREEZING CYLINDER (EVAPORATOR)

The freezing cylinder is made of a stainless steel vertical tube on which exterior is wrapped around the cooling coil with the evaporating chamber and in its interior is located the auger which rotates on its vertical axis and it is maintained aligned by the top and bottom bearings. A water seal system is located in the bottom part of the freezer while at the top end is fitted the ice breaker.

The water constantly flowing into the cylinder bottom part, freezes into ice when in contact with the cylinder inner walls. The ice is then lifted up by the rotating auger and compacted and forced out by the ice breaker.

K. ICE BREAKER

The ice breaker is made by several rectangular openings where the ice is forced to pass through. By undergoing this, the ice loses its excess of water content so it drops into the bin in hard dry bits of ice.

In the ice breaker it is housed the top bearing which is made of two roll bearings positioned to withstand the auger axial and radial loads. This bearing is lubricated with a food grade - water resistant grease.

NOTE. *It is advisable to check the conditions of both the lubricant grease and the bearings every six months.*

L. DRIVE GEAR MOTOR

This motoreducer is made of a single phase electric motor with permanent capacitor directly fitted on a gear box.

The drive motor rotor is kept aligned on its vertical axis by two ball bearings permanently lubricated. The gear case contains a train of three spur gears the first one of which is in fiber

to limit the noise level. All the three gears are encased in case bearings and are covered by lubricant grease (MOBILPLEX IP 44).

Two seal rings, one fitted on the rotor shaft and the other on the output shaft keep the gear case sealed.

However, the interior can be inspected and serviced by unbolting the two halves of the aluminium gear case housing.

The gear reducer output shaft is connected to the freezer auger by a ratched coupling which is made of two toothed halves that engages themselves only if turned in the correct direction namely, counterclockwise.

M. FAN MOTOR (Air cooled version)

The fan motor is controlled through the P.C. BOARD and the TRIAC by the condenser temperature sensor. Normally it operates to draw cooling air through the condenser fins.

In cold ambient situation, the fan motor can run at intermittance as the condenser pressure must be kept between two corresponding head pressure values.

N. COMPRESSOR

The hermetic compressor is the heart of the refrigerant system and it is used to circulate and retrieve the refrigerant throughout the entire system. It compresses the low pressure refrigerant vapor causing its temperature to rise and become high pressure hot vapor which is then released through the discharge valve.

O. ICE DISPENSER DRIVE MOTOR

Located on the upper side of the storage bin, it turns by a milled shaft the dispensing vane placed inside the round storage bin.

By rotating, the dispensing vane pushes the ice towards the bottom rectangular opening so to force the nugget ice to go through the bottom outlet spout.

P. STORAGE BIN

Round shaped it is located in the front of the ice machine and has the main reason to store the nugget ice produced by the evaporator until it reaches its maximum level controlled by an infrared optical system. In its bottom is placed the ice spout as well as the water drain hole. Inside the ice spout opening is also located the water outlet tube connected to the solenoid valve.

Q. DISPENSING WATER SOLENOID VALVE

Energized and controlled by the PC Board, it allows a metered quantity of not chilled water to be dispensed through the same opening of the ice.

SETTING THE DISPENSING SELECTOR

Setting the dispensing time

It's possible to modify the dispensing time to 5, 10, 3 or 1.5 seconds. To modify the original setting time (5 seconds):

- Push and hold the 4th switch (CONTINUOUS) for 10 seconds until the first 3 lights start to blink,
- Push & release the 1st switch (ICE) for a 1.5 second dispense.
- Push & release the 2nd switch (ICE AND WATER) for a 3 second dispense.
- Push & release the 3rd switch (WATER) for a 1.5 second dispense.

The unit resumes a default dispense setting (Ice, Ice and Water or Water) after each dispense.

To modify the resume mode (from factory set to ICE) push the desired switch (ICE, ICE AND WATER or WATER) for 5 seconds.

H. CHECK OF THE DISPENSING OPERATING MECHANISM

To check for the correct operation of the dispensing mechanism:

a) First, select the Dispensing Mode by pushing the proper membrane button.

b) Place a glass or a carafe in front of the two Optical Dispensing Devices.

c) The dispensing drive motor and/or the water solenoid valve starts. Ice and/or water is discharged through the bottom plastic spout.

The drive motor and/or the water solenoid valve remains in operation (per dispensing time settings) unless the glass or carafe is removed.

Push the CONTINUOUS switch and check again for the dispensing mechanism operation per the steps above.

The drive motor and/or the water solenoid valve will remain in operation until the glass or carafe is removed.

I. If connected, remove the refrigerant service gauges and re-attach the service panels.

J. Instruct the owner/user on the general operation of the ice machine and its required cleaning and care.

Note: If all the dispensing selector lights are blinking, the main control board (on the right side of the unit) has sensed a problem with the machine's operation. Check the main board's diagnostic lights for further information.



SERVICE DIAGNOSIS

SYMPTOM	POSSIBLE CAUSE	SUGGESTED CORRECTION
Unit will not run	Blown fuse in P.C. Board	Replace fuse & check for cause of blown fuse
No LED lights	Master switch in OFF position	Turn switch to ON position
	Inoperative P.C. Board	Replace P.C. Board
	Loose electrical connections	Check wiring
6th Yellow LED glows	Inoperative or dirty ice level control	Replace or clean ice level control
5th Yellow LED glows	Shortage or too soft water	See remedies for shortage of water or install a mineral salt metering device
2nd LED glows	High head pressure	Dirty condenser. Clean
		Inoperative fan motor. Replace
3rd Yellow LED blinks	Too high evap. temperature	Check and charge refrigerant system
	Shortage or lack of refrigerant	
3rd Yellow LED glows	Gear motor tends to run on reverse	Check gear motor capacitor
	Too low gear motor rotating speed	Check rotor bearings, freezer bearings and interior of freezer for scores. Replace whatever is worn or damaged.
	No rotation of gear motor	Check for power to drive motor (16 A fuses)
		Check for stator winding
	Gear motor starts and stops	Check for correct operation of drive after a while motor magnetic sensor
		Check for correct magnetic capacity of magnetic cylinder
Compressor cycles intermittently	Low voltage	Check circuit for overloading
		Check voltage at the supply to the building. If low, contact the power company
	Non-condensable gas in system	Purge the system
	Compressor starting device with loose wires	Check for loose wires in starting device
Low ice production	Capillary tube partially restricted	Blow charge, add new gas & drier, after evacuating system with vacuum pump
	Moisture in the system	Same as above
	Low water level in the freezer	Adjust to approx 20mm below ice spout
	Shortage of refrigerant	Check for leaks & recharge
	Pitted or stained auger surface	Clean or replace auger
Will not dispense	Dispense motor open	Check windings
	No power to dispense motor	Check harness connections from touch free sensors to control board & from board to motor
	Control board does not work	Trace harness from touch free sensors to PC board, jump the two center pins, the dispense motor should turn. If not replace the board
	Open harness	Check the harness for continuity, if any wire is open, replace the harness
	Defective sensor	If the above does not prove to be a problem, replace the sensors

GEMD270A

SERVICE DIAGNOSIS

SYMPTOM	POSSIBLE CAUSE	SUGGESTED CORRECTION
Wet ice	Ambient temperature too high	Move unit to cooler location
	High water level in the freezer	Lower to approx. 20mm below ice spout
	Faulty compressor	Replace
Machine runs but makes no ice	Water not entering in the freezer	Air lock in feed line to freezer.
		Clogged feed line to freezer. Clean it
	Gear stripped	Check and repair
	Moisture in the system	Purge, replace drier and re-charge
Water leaks	Water seal leaking	Replace water seal
	Water feed line to freezer leaking	Check and fasten hose clamp
	Float valve not closing	Check and adjust float valve setting screw
Excessive noise or chattering	Mineral or scale deposit on auger	Remove and manually polish auger and inner freezer walls and inner walls of freezer barrel using emery paper
	Low suction pressure	Add refrigerant to increase suction pressure
	Water feed line to freezer clogged	Vent and clean it
	Low water level into freezer	Adjust to approx. 20 mm below ice spout
Gear motor noise	Worn rotor bearings	Check and replace
	Shortage or poor lubricant in gear case	Check for proper lubricant level by opening gear case.
		Top of gears must be covered with lubricant
	Gear case bearings and gear racers worn out	Check and replace worn parts
Shortage of water	Strainer at water inlet fitting clogged	Remove strainer and clean
	Float reservoir water nozzle clogged-up nozzle	Remove float valve and clean

MAINTENANCE AND CLEANING INSTRUCTION

A. GENERAL

The times and the procedures for maintenance and cleaning are given as guides and are not to be construed as absolute or invariable. Cleaning especially will vary depending upon local water and ambient conditions and the ice volume produced. Each ice machine must be maintained individually, in accordance with its particular location requirements.

B. Ice machine

The following maintenance should be scheduled at least two times per year on these ice machines:

1. Check and clean the water line strainer or filter.
2. Remove the cover from the float reservoir – be careful to not damage the two water sensors –and depress the float to make sure that a full stream of water enters the reservoir.
3. Check that the ice machine is level.
4. Check that the water level in the water reservoir is below the overflow but high enough that it does not run out of the spout opening.

NOTE: The float must stop the incoming water flow when the rubber housed in the setting screw is perpendicular to the water nozzle.

5. Clean the water system, water reservoir and the interior of freezing cylinder using a solution of ice machine cleaner. Refer to section C. CLEANING INSTRUCTIONS OF WATER SYSTEM for cleaning procedures and after cleaning will indicate frequency and procedure to be followed in local areas.

NOTE: Cleaning requirements vary according to the local water conditions and individual user operation.

6. If required, polish the two sensor rods secured to the float reservoir cover. Heavy scale sediment on them can be removed with the help of a bit of ice machine cleaner plain.
7. With the ice machine and fan motor OFF clean condenser using vacuum cleaner, whiskbroom or non-metallic brush taking care to do not damage the condenser temperature sensor.
8. Check for water leaks and tighten drain line connections. Pour water into the sink to be sure that drain line is open and clear.
9. Check the ice level control sensor to test shut-off. Put your hand between the light source

and the receiver on the upper side of the storage bin to cut off the light beam for at least 6 seconds.

This should cause the 6th RED LED on the front of the PC board to turn off and, 6 seconds later the ice machine will cease operation and the 6th YELLOW LED will turn on. Once you remove your hand the ice machine should resume normal operation within a few seconds.

NOTE: The ice level control uses a device that senses light, therefore they must be kept clean enough so they can “see”.

Every month clean/wipe the sensing “eyes” with a clean soft cloth.

10. Check for refrigerant leaks and for proper frost line, approx. 8 inches from the compressor.

When in doubt of refrigerant charge, connect refrigerant gauges to corresponding Schröder valves and check for correct refrigerant pressures.(See Operating Pressure on page 10 & 11 of this manual).

11. Check that fan blades move freely and are not touching any surfaces.
 12. Remove the ice spout cover, loosen the bolt securing the casting ice sweep and remove it; then inspect the top bearing. Wipe away existing grease and apply a coating of food grade waterproof grease.
- NOTE: Use of food-grade, waterproof grease to lubricate the top bearing is recommended.
13. Turn the ice-dispensing spout and remove it. Wash and sanitize it.
 14. Remove the sink grill for washing and sanitizing.

GEMD270A

CLEANING INSTRUCTIONS OF WATER SYSTEM

1. Switch OFF the power supply to the GEMD270A.
2. Remove the top panel and the top cover of the storage bin with the dispensing drive motor.
3. Remove all ice stored in the bin to prevent it from getting contaminated with the cleaning solution.
4. Close the water shutoff valve on water line.
5. Remove the left side panel to gain access to the water reservoir.
6. Remove the float reservoir cover and jump the two water level sensors with a piece of copper wire.
7. Remove the right service panel and loosen the drain plug from the water purge tube to drain all of water out of the freezer. Then re-plug the purge tube.

CLEANING

8. Prepare the cleaning solution by diluting it in a plastic container with 2.1 quarts (2 liters) of warm water (95°-115°F) with 7 ounces (0.2 liters) of ice machine cleaner.

WARNING: Ice machine cleaner contains Phosphoric and Hydroxyacetic acids. These compounds are corrosive and may cause burns if swallowed, DO NOT induce vomiting. Give large amounts of water or milk and call a Physician immediately. In case of external contact, flush with water. KEEP OUT OF THE REACH OF CHILDREN

9. Pour the cleaning solution into the water reservoir until it reaches the proper level.
10. After 15 minutes switch ON the Master switch to start the unit.
11. Wait till the machine starts to discharge ice, then continue to slowly pour the cleaning solution into the water reservoir taking care to maintain the level just below the overflow.

NOTE: The ice made with the cleaning solution is slushy and colored. It may also lose fluidity

creating some resistance in being elevated and extruded; this situation can be heard by the creaking noise made by the ice.

If this should occur it is recommended that you stop the ice machine for few minutes in order to allow the ice in the freezer to partially melt.

12. When all of the cleaning solution has been used up, open the water shutoff valve to allow new fresh water to flow into the reservoir. Let the unit continue to run until the ice resumes the normal color and hardness.

13. Stop the ice machine and pour warm water on the ice deposited into the storage bin to melt it.

NOTE: DO NOT use ice produced with the cleaning solution. Be sure none remains in the bin.

SANITATION INSTRUCTIONS

14. Mix 4 oz of 40 CFR approved sanitizer Nu-Calgon IMS III and 2.5 gallons of (90°F to 110°F) potable water.

15. Pour the sanitizing solution into the reservoir until it is full and wait 2 minutes.

16. Leave the unit running for approx 10-15 minutes then remove the copper wire used to jump the two sensors for the water level and place the cover back on the float reservoir.

17. Drain the solution from the system by loosening the drain plug from the water purge tube to drain all of water out. Then re-plug the purge tube and melt the ice in the storage bin pouring hot water (90°F to 110°F).

NOTE: DO NOT use ice produced with the sanitizing solution.

18. With a sponge moistened with the sanitizing solution, wipe clean all bin interior surfaces, ice sweep, and ice dispenser chute.

19. Return all panels to their normal position and secure with original screws.

REMEMBER: To prevent the accumulation of undesirable bacteria it is necessary to sanitize the interior of the storage bin with an anti-algae disinfectant solution every week.

REMOVAL AND REPLACEMENT

Bearings, Auger, Water Seal

Note: Metric tools are required for this procedure.

Disconnect electrical power.

1. Remove all panels and the sink assembly.
2. Remove the spout cover.
3. Use a 17mm socket to remove the top bolt holding the ice sweep to the auger.
4. Use a 13mm socket to remove the four bolts holding the breaker to the auger.
5. Lift up to remove breaker.

To remove top bearing:

6. Remove snap ring from the top of the breaker.
7. Turn breaker over and using a 3/4" punch or bolt, tap the bearing out from the bottom.

To remove auger:

8. After removing breaker, pull up on the auger to remove it.

To remove water seal or bottom bearing.

9. Remove bin cover.
10. Disconnect drain and water line from bin.
11. Remove nut holding bin to chassis.
12. Pull bin out of machine.
13. Remove screws holding air deflector to chassis and pull deflector out of the unit.
14. Remove screws holding reservoir to bulkhead panel.
15. Remove screws holding bulkhead panel to chassis frame, push panel back several inches.
16. Use a 13 mm open end or box wrench and remove the three bolts holding the adapter stand to the evaporator.
17. Lift evaporator up and off the stand.
18. Tap water seal and bottom bearing out of the evaporator from the top down.

To remove gear reducer.

1. Disconnect power leads and sensor wires from motor.
2. Perform steps to remove bottom bearing.
3. Use a 10 mm socket or box wrench to remove the 5 bolts holding the gear reducer to the unit.

4. Remove the gear reducer from the unit.

Reverse all individual sections to reassemble that section except for the top bearing and water seal. See the next page.

GEMD270A

TOP BEARING REPLACEMENT

Replacement of the top bearing

CAUTION

The GEMD270A top bearing is a unique design. It is two bearings in one: a flat thrust bearing and a roller bearing.

The bearing will separate if not installed properly. Do not attempt to install it unless it is secured as described in these instructions.

1. Carefully clean out the breaker, removing any debris or dirt. If using a new breaker, skip this step.
2. Separate the flat-bearing & thrust washer from the new roller bearing.

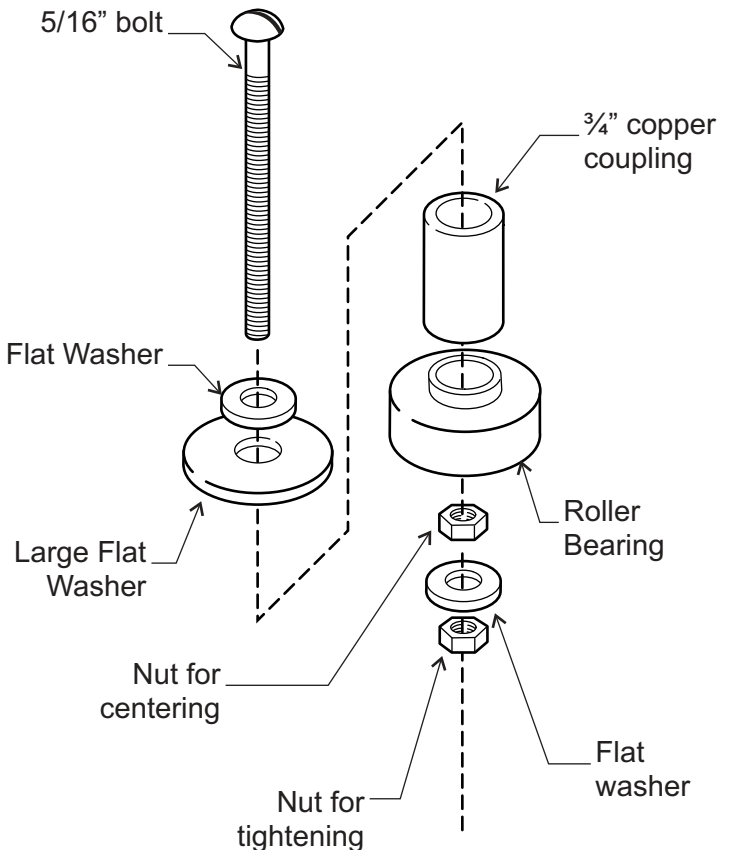
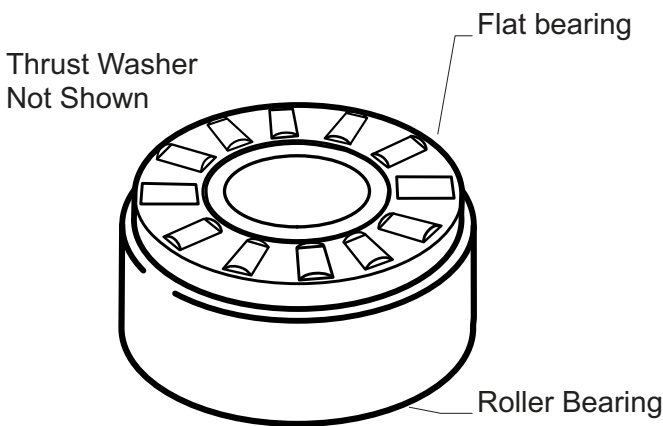

3. The bearing's inner race **must be supported during installation**. Make an insertion tool. Use a 5/16 - 18 x 3" bolt, a 3/4" copper coupling, two or three washers (one must be less than 3/4" OD to go inside the breaker) and two nuts to hold it together:

Place copper coupling onto top of bearing

Place large washers over coupling and small washer under bottom of bearing.

Insert bolt through large washers, coupling and bearing. Run one nut into bearing to center the bolt. Add small washer and nut. Tighten nut finger tight.

Construction of Bearing Insertion Tool

BEARING REPLACEMENT - CONTINUED

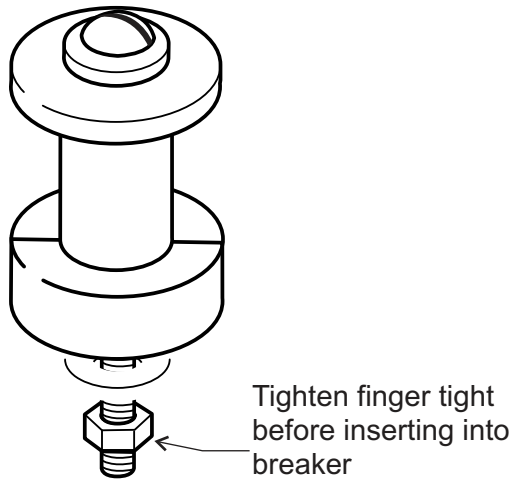

Bearing and Tool

4. Add food grade lube to the edges of the breaker where the bearing will be inserted.
5. Tap the new roller bearing into the breaker using a plastic mallet.

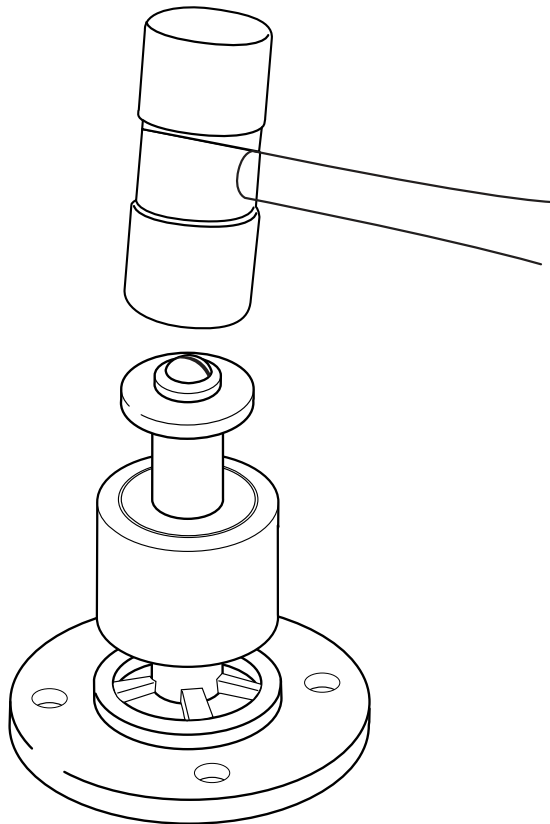

Tap Bearing & Tool into Breaker

6. Remove coupling, bolt, washers and nuts.
7. The roller bearing is fully seated when it is 13/16" from the top edge of the breaker.
8. Thoroughly lubricate the thrust bearing and place it on top of the roller bearing. The inner race of the roller bearing must project through the center of the flat thrust bearing.
9. Install the flat washer (provided with the new bearing) on top of the flat thrust bearing.
10. Return the snap ring to its normal position.
11. Add food grade water resistant grease to the top of the bearing area.
12. Assemble onto auger and secure with the original bolt.

GEMD270A

WATER SEAL

Stationary Half

1. Insert new water seal into bottom of evaporator.
2. Insert new bearing under the water seal, push or tap both in until the bottom of the bearing is flush
3. Assemble adapter to evaporator. Tightening the mounting bolts will correctly position the bottom bearing and bottom seal.

Rotating Half

1. Remove old rotating half from the auger. Clean the mounting area.
2. Place a bead of food grade sealant onto the shoulder of the auger where the rotating half of the water seal will be installed.
3. Wash the new seal in water. While wet, slip it onto the bottom of the auger, rubber side toward the auger. Push up until seated against the sealant. Do not allow any sealant to come into contact with the face of the seal.

