

Ice-O-Matic®

Installation, Start-up and Maintenance Manual

GEM-MFI Series

60 hz.



How To Use This Manual

Ice-O-Matic provides this manual as an aid to the end user and service technician in installation and maintenance of the **GEM-MFI Series** ice machines. Do not attempt to perform installation, start-up or maintenance unless you have read and fully understand this manual.

For a Service Provider, please reference our “Find a Service Technician” tab at www.iceomatic.com

Keep this manual for future reference.

The GEM-MFI Series Service Parts Manuals are available separately.

Ice-O-Matic icemakers and dispensers are not approved for outdoor installation.

WARNING: Always disconnect electrical power and shut off water supply whenever maintenance or repairs are performed on the ice machine and related equipment.

CAUTION: Always wear protective eyewear whenever maintenance or repairs are performed on the ice machine and related equipment.



AMERICAN FORESTS

Plant-a-Tree Program

As part of our commitment to the global environment, Ice-O-Matic is devoted to sustainability in every aspect of our business. To offset the carbon footprint of our factory in Denver, we not only recycle materials in our packaging and manufacturing but also recycle our industrial and office waste products.

More important, we partner with AMERICAN FORESTS and plant a tree for every ice machine we sell, thereby supporting reforestation of key regions throughout the world. Our goal is to plant 150,000 trees through our Global Sustainability program. Trees reduce topsoil erosion, prevent harmful land pollutants from getting into our waterways and replace air pollutants with fresh, clean oxygen.



Energy Efficiency

Ice-O-Matic is consistently working to improve the energy efficiency of our ice machines. We are uncompromising in our pursuit of both productivity and energy efficiency and are continually looking for ways to improve both, thereby delivering the best value in energy efficient

Ice-O-Matic Warranty

Every Ice-O-Matic ice maker is backed by a warranty that provides both parts and labor coverage. To view the warranty details, register products, or check your warranty status visit the “Warranty and Water Filter Registration” page on www.iceomatic.com

Table of Contents

Introduction Page i
Warranty Page i
Table Of Contents..... Page ii
Freight Claim Procedure..... Page iii

For The Installer (Guidelines) Page 1
For The Installer (Applications)..... Page 4
For The Installer (Location)..... Page 6
Remote Condenser..... Page 7

For The Plumber Page 12
For The Electrician..... Page 14
For The Installer (Completed Remote Installation) Page 16
For The Installer (Check List) Page 17

Start Up..... Page 19
Sanitizing and Cleaning Page 21
Condenser Cleaning..... Page 23
Service History..... Page 25

Important!**Inspect Promptly**

This merchandise has been carefully inspected and packed in accordance with the carrier's packing specifications. Responsibility for safe delivery has been assumed by the carrier. If loss or damage occurs, you as the consignee must file a claim with the carrier and hold the container for carrier's inspection.

Visible Loss or Damage

Any external evidence of loss or damage must be fully described and noted on your freight bill or express receipt and signed by the carrier's agent. Claim should be filed on a form available from the carrier.

Concealed Loss or Damage

If loss or damage does not appear until merchandise has been unpacked, make a written request for inspection by the carrier within 15 days of the delivery date. Then file a claim on a form from the carrier.

File Claim Without Delay Do Not Return Damaged Merchandise to Ice-O-Matic

Installation Guidelines:

For proper operation of the Ice-O-Matic ice machine, the following installation guidelines must be followed. Failure to do so may result in loss of production capacity, premature part failures, and may void all warranties.

Ambient Operating Air Temperatures: (Not including remote condenser)

Minimum Operating Temperature: 50°F (10°C)

Maximum Operating Temperature 100°F (38°C)

Note: Ice-O-Matic ice makers and dispensers are not approved for outdoor installation.

Incoming Water Supply

Minimum incoming water temperature: 40°F (4.5°C)

Maximum incoming water temperature: 100°F (38°C)

Minimum incoming water pressure: 20 psi (1.4 bar)

Maximum incoming water pressure: 80 psi (4.1 bar)

Note: If water pressure exceeds 80 psi a water pressure regulator must be installed.

Note: It is not recommended to connect a water softener because the ice may be more wet and slushy than desired.

Water Softeners add salinity raising the freeze point resulting in “softer” ice. This results in lower ice production.

Drains

All drain lines must be installed per local codes. Flexible tubing is not recommended. Route bin drain, vented float overflow drain and water condenser drain individually to a floor drain. The use of condensate pumps for draining water is not recommended by Ice-O-Matic. Ice-O-Matic assumes no responsibility for improperly installed equipment.

Water Filtration

A water filter system should be installed with the ice machine.

Clearance Requirements

Self-contained air cooled ice machines must have a minimum of 6 inches (15cm) of clearance at the rear and sides of the ice machine for proper air circulation.

Stacking

Ice-O-Matic GEM-MFI Series ice machines are not designed to be stacked.

Dispenser Application

The GEM ice machine is approved for specific dispenser applications, reference page 4.

The MFI Series is not approved for dispenser applications.

Electrical Specifications

Refer to the serial plate at the rear of the ice machine to make sure proper voltage and circuit breaker size have been supplied. Make sure the machine is on a dedicated circuit. The GEM-MFI Series are not supplied with an electrical power cord and will need to be installed and wired per local electrical codes.

Adjustments

Level the machine within 1/8 inch in all directions. Adjust the cabinet or bin legs as required.

Check the bin control for proper operation.

Check the water level in the reservoir for proper adjustment.

Check the water regulating valve adjustment if water cooled.

Air and Water Cooled

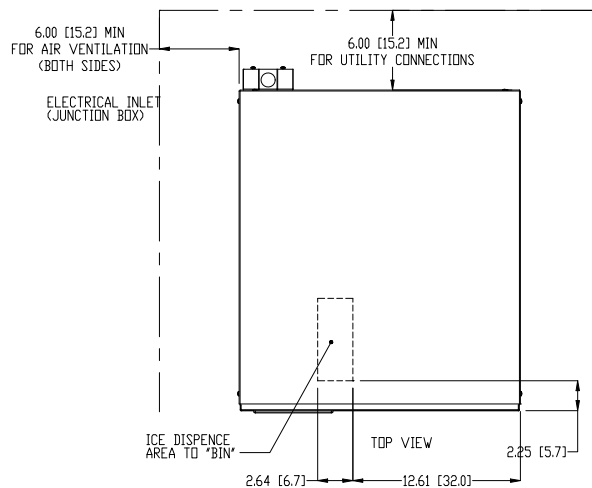
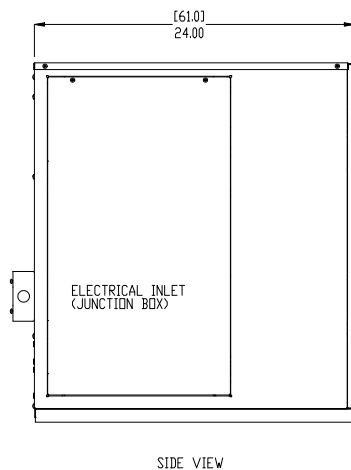
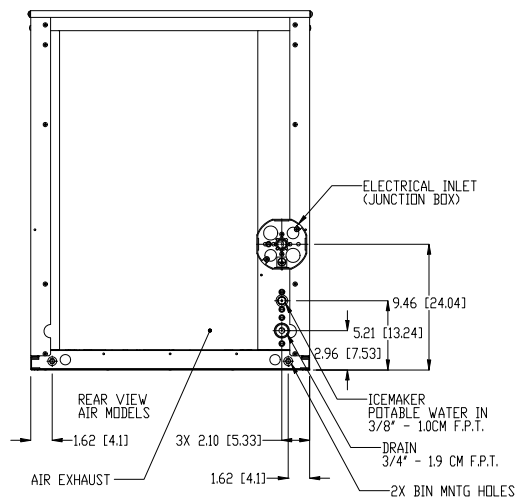
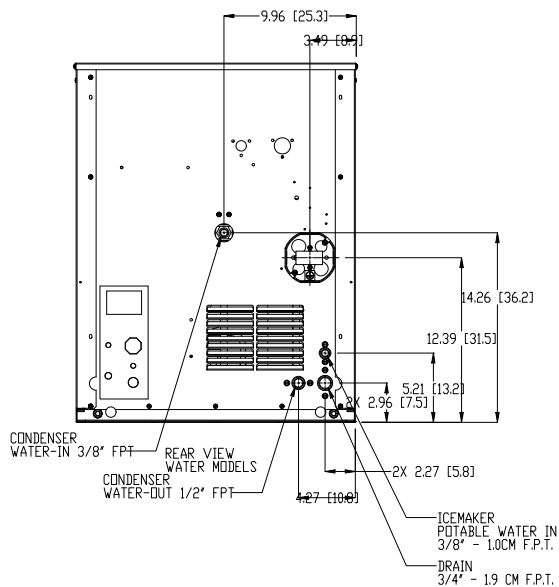
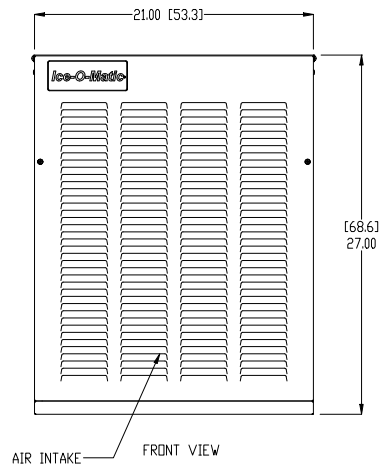

Remote

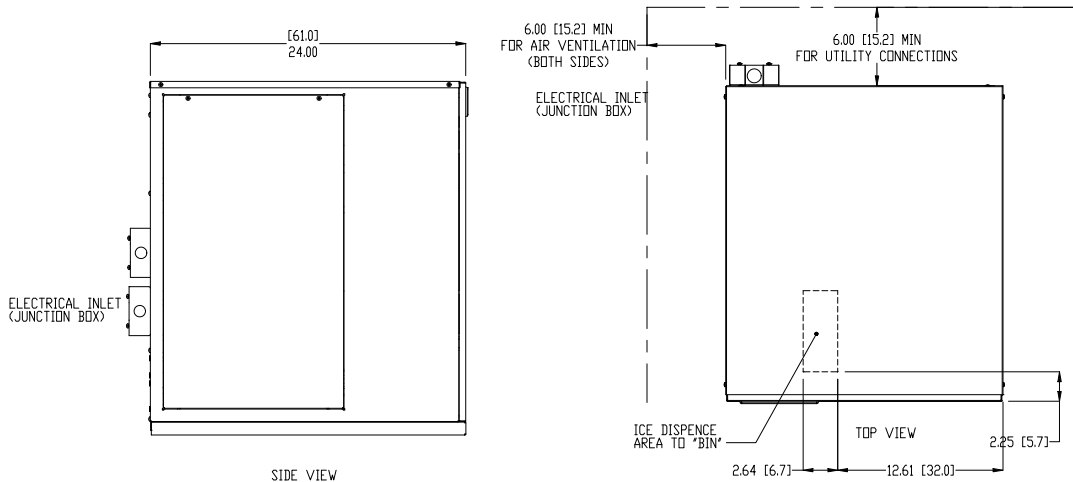
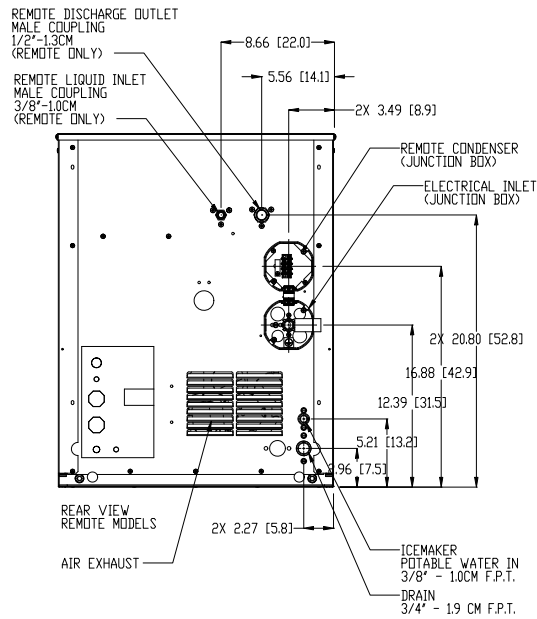
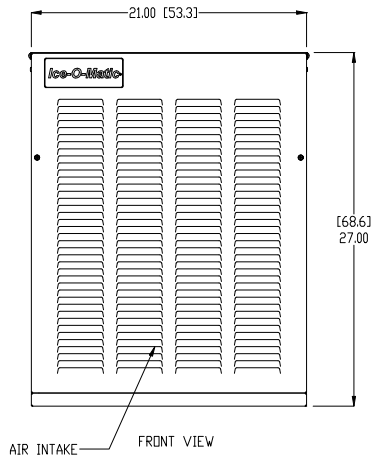

Bin Application

The GEM-MFI Series is designed to fit the following Ice-O-Matic Bins

- B42, using Bin Top KBT 24
- B25, B40 or B55 using Bin Top KBT 19.
- B100, using Bin Top KBT 23 (one unit) or KBT 22 (two units).
- B700-30, B1000-48, B1300-48, B1325-60 B1600-60

Dispenser Application

The GEM Series can be placed on and used with certain ice and beverage dispensers. Kits are required for proper operation. The MFI Series is not approved for dispenser application.

Dispenser	GEM0450	GEM0650	GEM0956/GEM1306A
ICE-O-Matic IOD150	KBT15022, KGEMDIV	KBT15022, KGEMDIV	KBT15022, KGEMDIV
ICE-O-Matic IOD200 or IOD250	KBT25022+ KGEMDIV+ KGEMBIOD	KBT25022+ KGEMDIV+ KGEMBIOD	KBT25022+ KGEMDIV+ KGEMBIOD
Cornelius ED or DF150	KBT15022+R629088514*	KBT15022+R629088514*	KBT15022+R629088514*
Cornelius ED or DF200	KBT25022+KGEM200	KBT25022+KGEM200	KBT25022+ KGEM200
Cornelius ED or DF250	KBT25022+ KGEM250	KBT25022+KGEM250	KBT25022+KGEM250
Cornelius ED300	KGEM300+629087966*	KGEM300+629087966*	KGEM300+629087966*
Cornelius Flavor Fusion 255	KDIL-N-CFF and Cornelius adapter 62988681 (Black)	KDIL-N-CFF and Cornelius adapter 62988681 (Black)	KDIL-N-CFF and Cornelius adapter 62988681 (Black)
Lancer (Must have N in part number) 30 inch 4500 model	KDIL-N-L and Lancer Part Number 82-3491	KDIL-N-L and Lancer Part Number 82-3491	KDIL-N-L and Lancer Part Number 82-3491

* Cornelius Part Number

All the dispensers have automatic agitation to keep the ice from clumping. If agitation is too frequent, the Pearl Ice will be damaged and will become difficult to dispense. The Ice-O-Matic and Cornelius dispensers need to be set to 2 seconds on every 3 hours and the Lancer needs to be set to 4 seconds on, 150 seconds off.

The Ice-O-Matic and most Cornelius dispensers also have a restrictor plate at the outlet of the hopper. When used, that plate should be adjusted to be 1.5 inch open to limit the speed of the Pearl Ice flows out during dispensing.

Ice Machine Specifications

Model Number	WxDxH (Inches)	Basic Electrical	Condenser	Minimum Circuit Ampacity	Maximum Fuse Size	Refrigerant Charge oz. R404
GEM0450A2	21x24x27	115/60/1	Air	15.75	20	22
GEM0450W2	21x24x27	115/60/1	Water	14.35	20	18
GEM0650A2	21x24x27	115/60/1	Air	19.50	30	24
GEM0650W2	21x24x27	115/60/1	Water	18.30	30	19
GEM0650R2	21x24x27	115/60/1	Remote	22.50	30	208
GEM0956A2	21x24x27	208-230/60/1	Air	11.30	15	30
GEM0956W2	21x24x27	208-230/60/1	Water	10.80	15	22
GEM0956R2	21x24x27	208-230/60/1	Remote	14.10	20	208
GEM1306A	21x24x27	208-230/60/1	Air	15.80	20	30
MFI0500A2	21x24x27	115/60/1	Air	15.75	20	22
MFI0500W2	21x24x27	115/60/1	Water	14.35	20	18
MFI0800A2	21x24x27	115/60/1	Air	19.50	30	24
MFI0800W2	21x24x27	115/60/1	Water	18.30	30	19
MFI0800R2	21x24x27	115/60/1	Remote	22.50	30	208
MFI1256A2	21x24x27	208-230/60/1	Air	11.30	15	30
MFI1256W2	21x24x27	208-230/60/1	Water	10.80	15	22
MFI1256R2	21x24x27	208-230/60/1	Remote	14.10	20	208
MFI1506A	21x24x27	208-230/60/1	Air	15.80	20	30

Location:

Ice-O-Matic ice machines are designed to be installed indoors in a controlled environment. Install the ice machine in a location where it has enough space around it to be accessible for service. A minimum of 6 inches must be allowed at the back for air circulation on air cooled models. Try to avoid hot, dirty and crowded locations. Be sure that the location of the machine is within the environmental limitations.

Storage Bin:

Remove the bin packaging. Tip the storage bin on its back, using parts of the packaging to protect the exterior finish. Remove the skid and install the legs into the threaded holes in the bottom of the bin. Turn the leg levelers all the way in preparation for leveling later. Return the bin to the upright position.

Note: Do not push the bin into position, but lift it there. Pushing a bin, especially one with ice in it, can cause damage to the bin legs and mounts.

Install the appropriate bin top according to the instructions provided with the bin top.

Ice machine:

The ice machine is heavy, so the use of a mechanical lift is recommended for lifting the machine high enough to install on top of the bin. After the unit is placed on the bin, line it up so it is even with the back side. Secure the ice machine to the bin with the hardware provided with the ice machine. Remove the front panel and remove any shipping blocks or packaging material.

Proper functioning of the bin door requires the bin door, when it is opened, to be in a stable position. If the ice machine is too far forward on the bin, the opened door may not be stable, resulting in an unexpected closing of the bin door.

If the ice machine is to be mounted on a bin or dispenser other than an Ice-O-Matic, refer to the manufacturer's instructions for machine mounting. Ice-O-Matic will not be responsible for damage or injury that results from unexpected closing of the bin door as a result of the ice machine being too far forward on the bin.

Water Limitations:

An ice machine is a food manufacturing plant: it takes a raw material, water and transforms it into a food product, ice. The purity of the water is very important in obtaining pure ice and maximizing product life. This section is not intended as a complete resource for water related questions, but it does offer these general recommendations:

- Check with a water treatment specialist for a water test and recommendations regarding water filters and treatment.
- In most cases, the water used to make ice should be filtered or treated, depending upon the water. There is no one type of water filter that is effective in all situations. That is why a water test is important.

RO Water Limitations:

Water conductivity must be no less than 35 microSiemens/cm.

Notice:

Ice-O-Matic ice machines are designed and manufactured with the highest regard for safety and performance and meet or exceed the standards of UL, NSF and CUL.

Ice-O-Matic assumes no liability or responsibility of any kind for products manufactured by Ice-O-Matic that have been altered in any way, including the use of any part and/or other components not specifically approved by Ice-O-Matic.

Ice-O-Matic reserves the right to make design changes and/or improvements at anytime. Specifications and design are subject to change without notice.

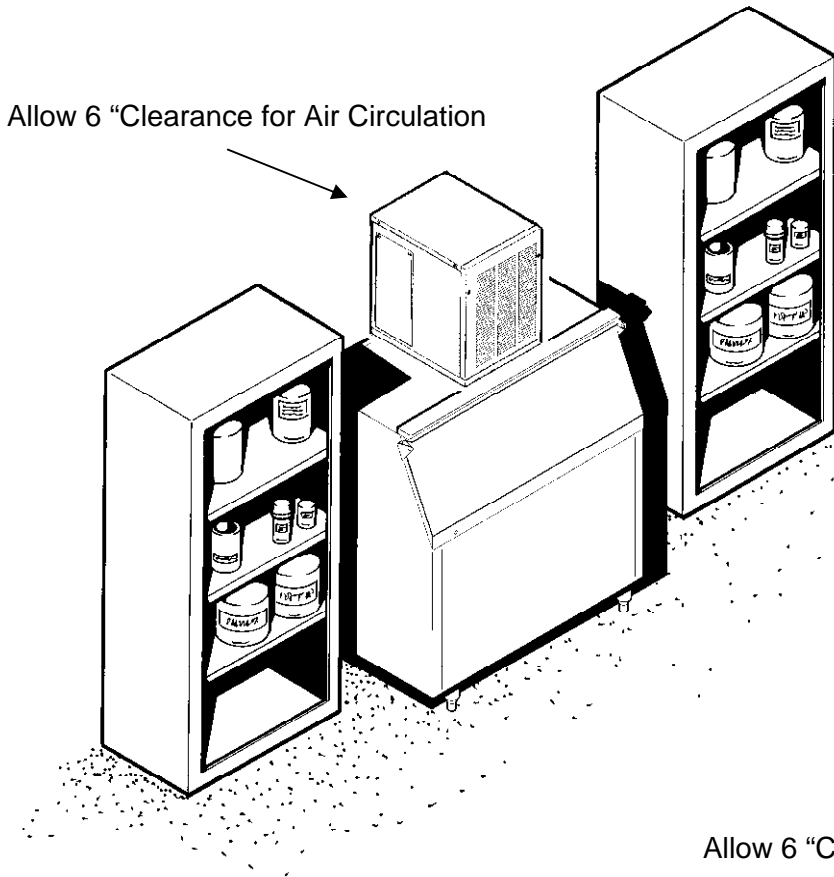

Allow 6 "Clearance for Air Circulation

A proper installation locates the ice machine indoors, but in a place where the heat and noise it produces are not objectionable.

Air cooled machines discharge hot air out the back and must have a minimum of 6 inches of clearance behind the ice machine.

Space for maintenance access is also important. If two units are placed side by side on a bin, side access becomes even more important.

Two Units on One Bin

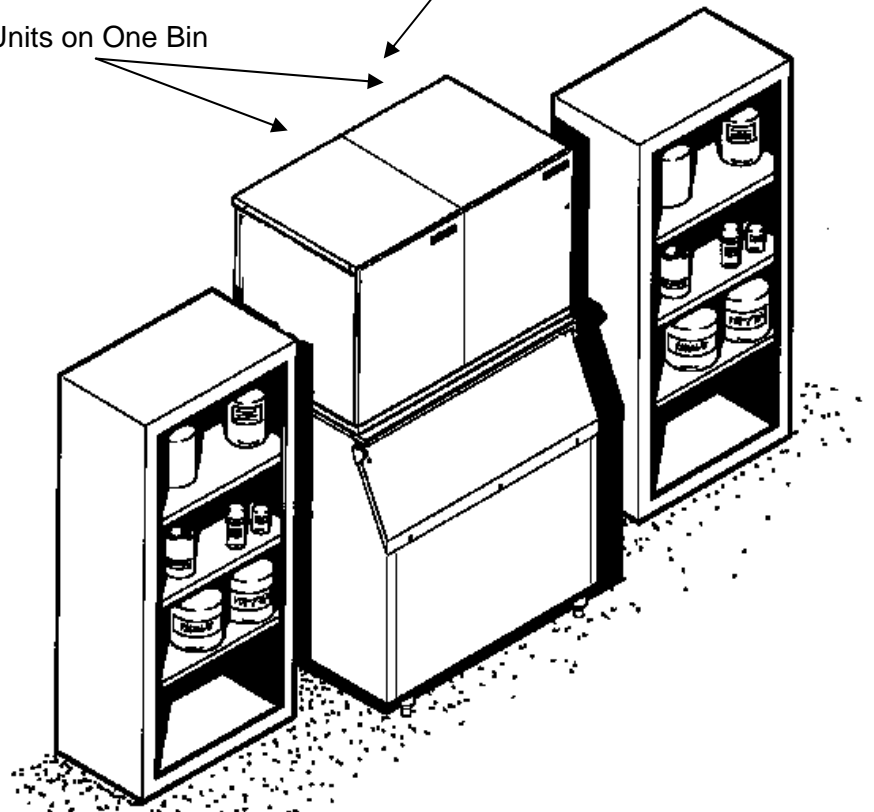

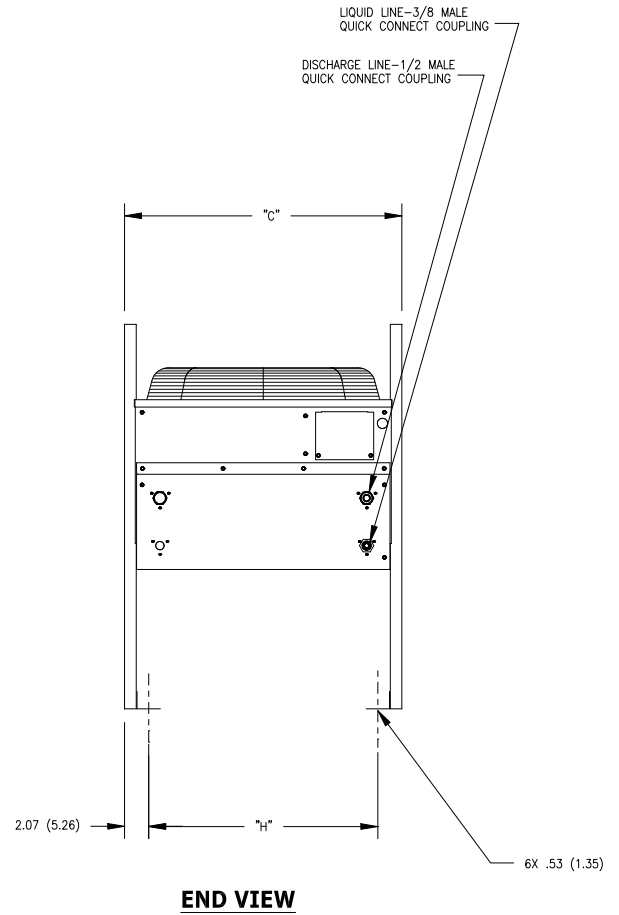
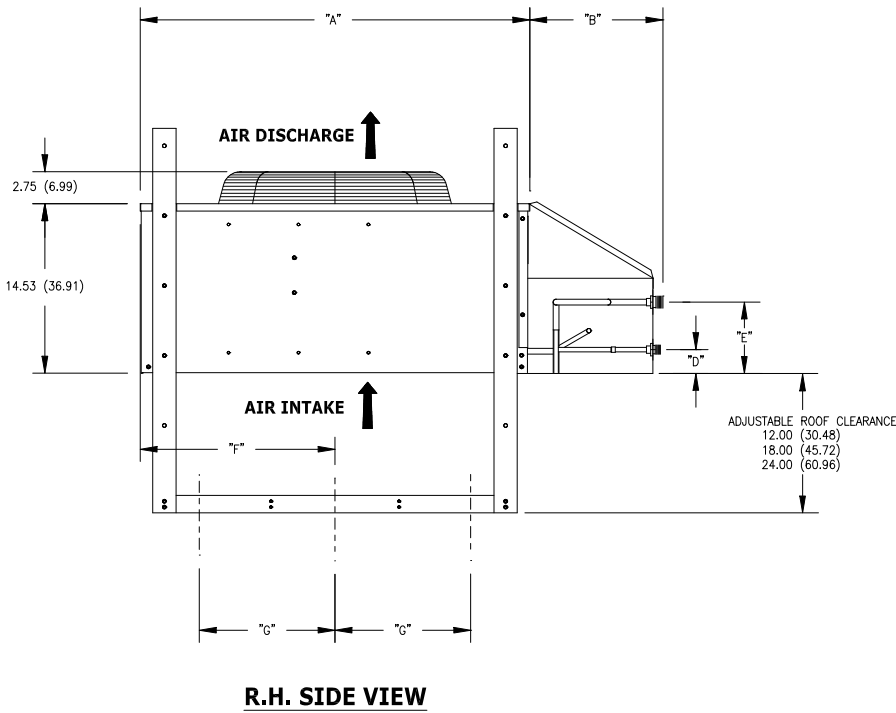
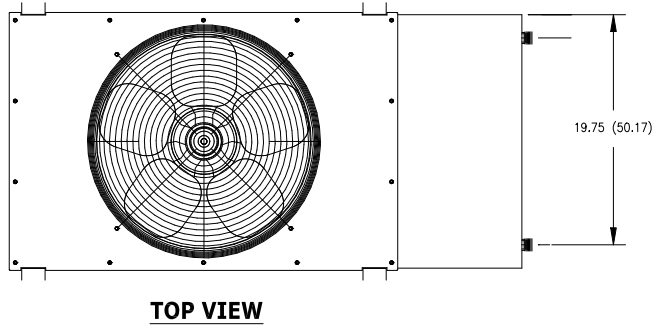

GRC Dimensions (Inches)	GRC1001	GRC1061	GRC1061
A	33.36	33.36	33.36
B	10.75	10.75	10.75
C	23.81	23.81	23.81
D	2.04	2.04	2.04
E	6.12	6.12	6.12
F	16.73	16.73	16.73
G	11.65	11.65	11.65
H	19.57	19.57	19.57
GEM/MFI Model Number	GEM0650R	GEM0956R	MF11256R

Line Sets

- RT325404 25 Foot Precharged Line Set
- RT340404 40 Foot Precharged Line Set

Use the following for planning the placement of the remote condenser relative to the ice machine.

Location Limits: Remote condenser location must not exceed ANY of the following:

- Maximum rise from the ice machine to the remote condenser is 35 physical feet.
- Maximum drop from the ice machine to the remote condenser is 15 physical feet.
- Physical line set maximum length is 100 feet.
- Calculated line set length maximum is 150 feet.

Calculation Formula

- Drop = $dd \times 6.6$ (dd= distance in feet)
- Rise = $rd \times 1.7$ (rd = distance in feet)
- Horizontal Run = $hd \times 1$ (hd = distance in feet)
- Calculation: Drop(s) + Rise(s) + Horizontal Run = $dd+rd+hd$ =Calculated Line Length

Configurations that do NOT meet these requirements must receive written authorization from Ice-O-Matic. This includes multipass or rack system remote condensers.

Do NOT:

- Route a line set that rises, then falls, then rises.
- Route a line set that falls, then rises, then falls.

Calculation Example 1:

The remote condenser is to be located 5 feet below the ice machine and then 20 feet away horizontally. (5 feet x 6.6=33 feet) + (20 feet) = 53 feet. This location would be acceptable.

Calculation Example 2:

The remote condenser is to be located 35 feet above the ice machine and then 100 feet away horizontally. (35 feet x 1.7=59.5 feet) + (100 feet) = 159.5 feet. 159.5 feet is greater than the 150 maximum is NOT acceptable.

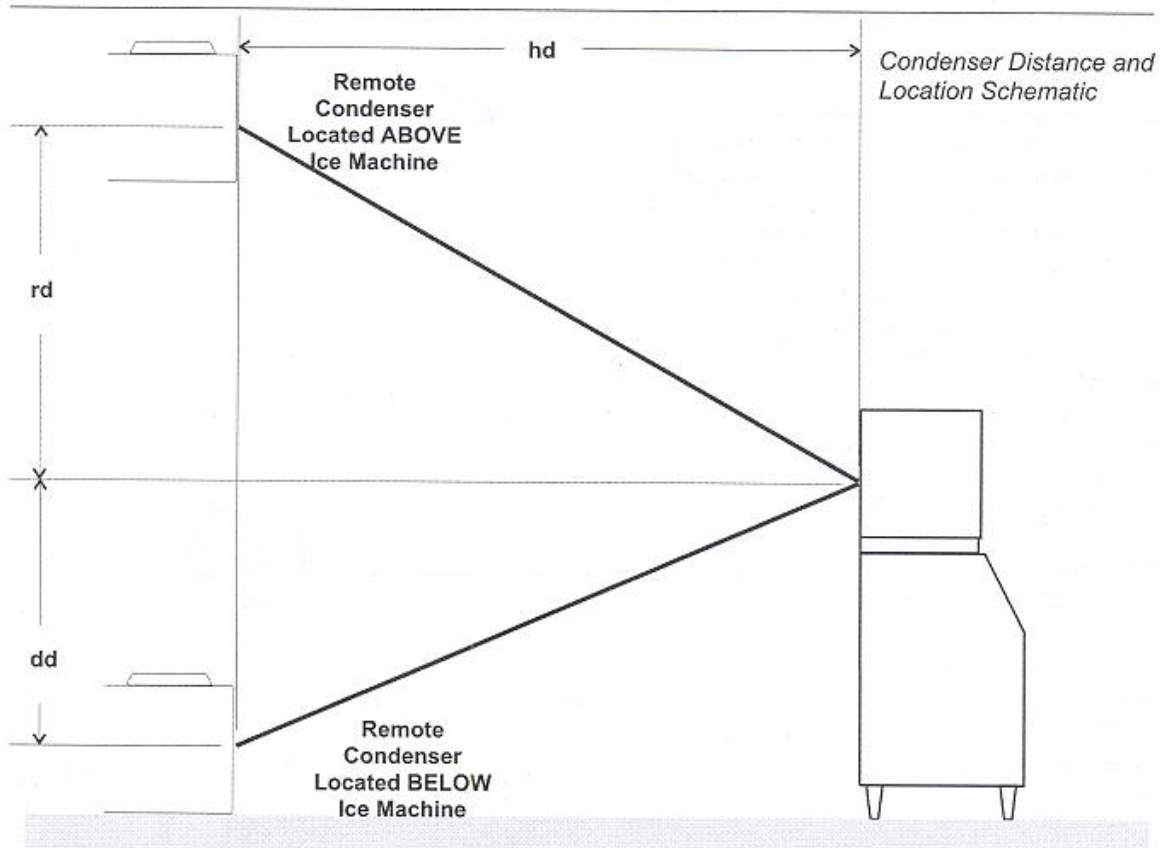

Remote Condenser Location:

Limited to a 25 foot or a 40 foot length of precharged refrigerant tubing connecting the ice machine to the remote condenser. The remote condenser must be above or level with the ice machine. Select the best available location, protecting the remote condenser from extremes of dirt, dust and sun. Meet all applicable building codes. Usually the services of a licensed electrician are required.

Roof Attachment:

1. Install and attach the remote condenser to the roof of the building, using the methods and practices of construction that conform to the local building codes, including having a roofing contractor secure the remote condenser to the roof.
2. Have an electrician connect the remote condenser fan motor to the ice machine, using the junction box at the back of the ice machine.

Precharged Line Set Routing

CAUTION: Do not connect the precharged tubing until all routing and forming of the tubing is complete. See the coupling instructions for connecting information.

1. Each set of precharged tubing refrigerant lines consists of a 3/8 diameter liquid line and a 1/2 inch diameter discharge line. Both ends of each line have quick connect couplings, one end has a Schrader valve connection, that end goes to the condenser.

Note: The openings in the building ceiling or wall, listed in the next step, are the minimum sizes recommended for passing the refrigerant lines through.

2. Have the roofing contractor cut a minimum hole for the refrigerant lines of 1.750 inch. Check local codes, a separate hole may be required for the electrical power to the condenser.

CAUTION: DO NOT KINK OR CRIMP REFRIGERANT TUBING WHEN INSTALLING IT.

3. Route the refrigerant lines through the roof opening. Follow straight line routing whenever possible. Any excess tubing **MUST** remain within the building.
4. Spiral the excess length of precharged tubing inside the building. Use a horizontal spiral (does not need to be as tight as illustrated) to avoid any traps in the lines.
5. Have the roofing contractor seal the holes in the roof per local codes.

CAUTION: The couplings on the sets of precharged lines are self sealing when installed properly. Carefully follow the instructions:

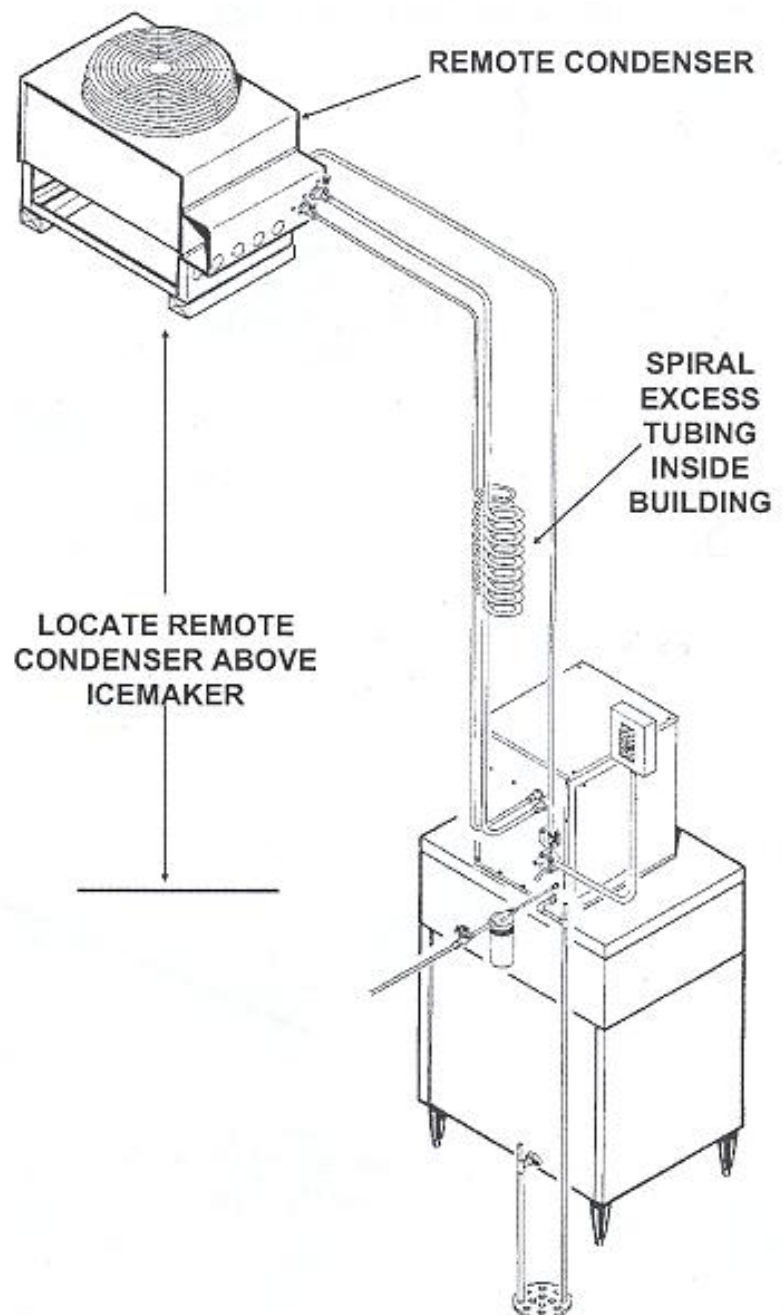

Typical Installation

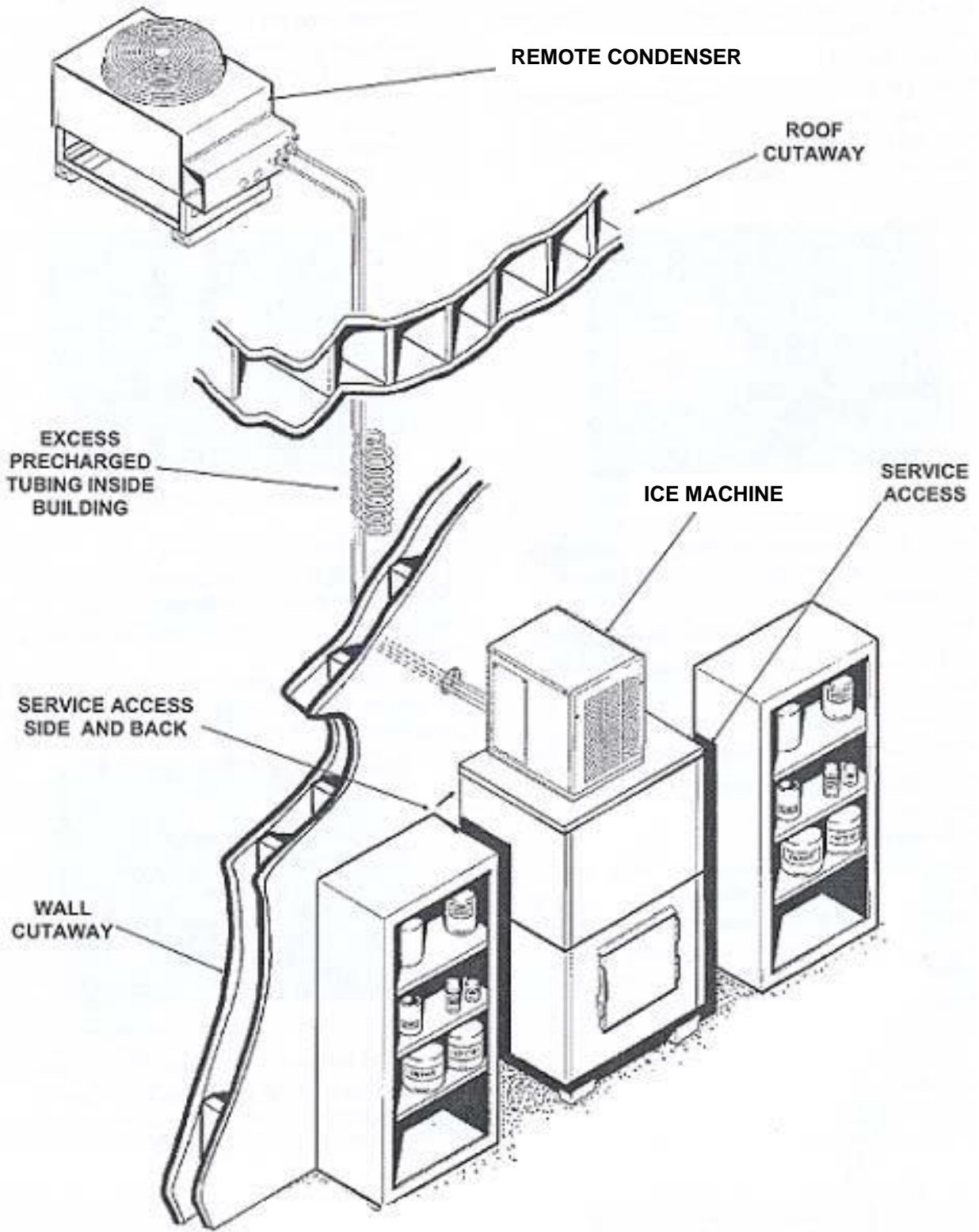

Coupling Instructions:**Initial Connections:**

1. Remove the protector caps and plugs. Wipe the seats and threaded surfaces with a clean cloth to be certain that no foreign matter remains on them.
2. Lubricate the inside of the couplings, especially the O-Rings with refrigerant oil.
3. Position the fittings on the correct connections on the remote condenser and ice machine.
 - The 1/2 inch discharge line (**Schrader valve end**) goes to the remote condenser fitting marked "Discharge Line"
 - The 3/8 inch liquid line (**Schrader valve end**) goes to the remote condenser fitting marked "Liquid Line".
 - The 1/2 inch discharge line goes to the ice machine fitting marked "Discharge Line".
 - The 3/8 inch liquid line goes to the ice machine fitting marked "Liquid Line".

**Final Connections:**

- 4a. Begin by tightening the couplings together by hand. Continue to turn the swivel nuts by hand until it is certain that the threads are properly engaged.

- 4b. Using two wrenches, one to rotate the swivel nut and one to hold the tubing, tighten each coupling. It is **CRITICAL** that **ONLY** the NUT on the precharged tube be turned or the diaphragms will be torn loose by the piercing knives and be loose in the refrigeration system causing severe operational problems.

Note: As the coupling is tightened, the diaphragms in the quick connect couplings will begin to be pierced. As that happens, there will be increased resistance to tightening the swivel nut.

- 4c. Continue tightening the swivel until it bottoms out or a very definite increase in resistance is felt (no threads should be showing). Do **NOT** over tighten.

5. Using a marker or pen, mark a line lengthwise from the coupling union nut to the bulkhead. Then tighten the coupling and additional 1/4 turn. As the nut turns, the line will show when the 1/4 turn is made.

6. After all connections are made, and after the king valve has been opened (do not open at this time) check the couplings for leaks.



Water Inlet:

- Air Cooled Models:** The recommended water supply is clean, cold water. Use 3/8 inch O.D. copper tubing, connect to the 3/8 inch FPT at the back of the cabinet. Install a hand valve near the machine to control the water supply.
- Water Cooled Models:** A separate 3/8 inch O.D. copper line is recommended, with a separate hand valve to control it. Connect to the 3/8 inch FPT condenser inlet at the back of the cabinet. The water pressure to all lines must always be above 20 psig, and below 80 psig.
- Water Treatment:** In most areas, a water filter of some type will be useful. In areas where the water is highly concentrated with minerals, the water should be tested by a water treatment specialist, and the recommendations of the specialist regarding filtration and/or treatment should be followed.

Drains:

- Air Cooled Models:** Connect a rigid drain tube to the 3/4 FPT drain fitting at the back of the cabinet. The drain is a gravity type, and a 1/4 inch per foot fall is the minimum acceptable pitch for the drain. There should be a vent at the highest point of the drain line, and the ideal drain receptacle would be a trapped and vented floor drain. Use only 3/4 inch rigid tubing.
- Water Cooled Models:** Connect a separate drain line to the 1/2 inch condenser drain connection at the back of the cabinet. Do not vent this drain.
- Storage Bin:** Connect a separate gravity type drain line to the ice storage bin drain. Vent this drain if there is a long horizontal run from the bin to the floor drain. Insulation of this drain line is recommended.

WATER COOLED MODELS

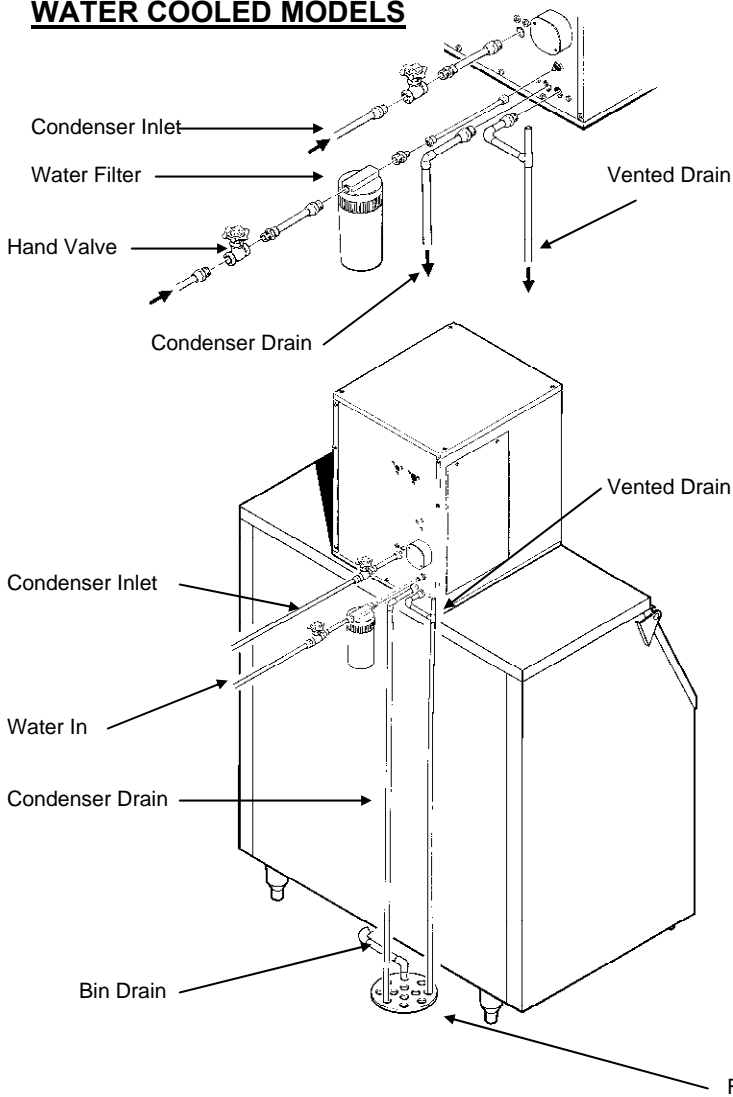

AIR COOLED MODELS

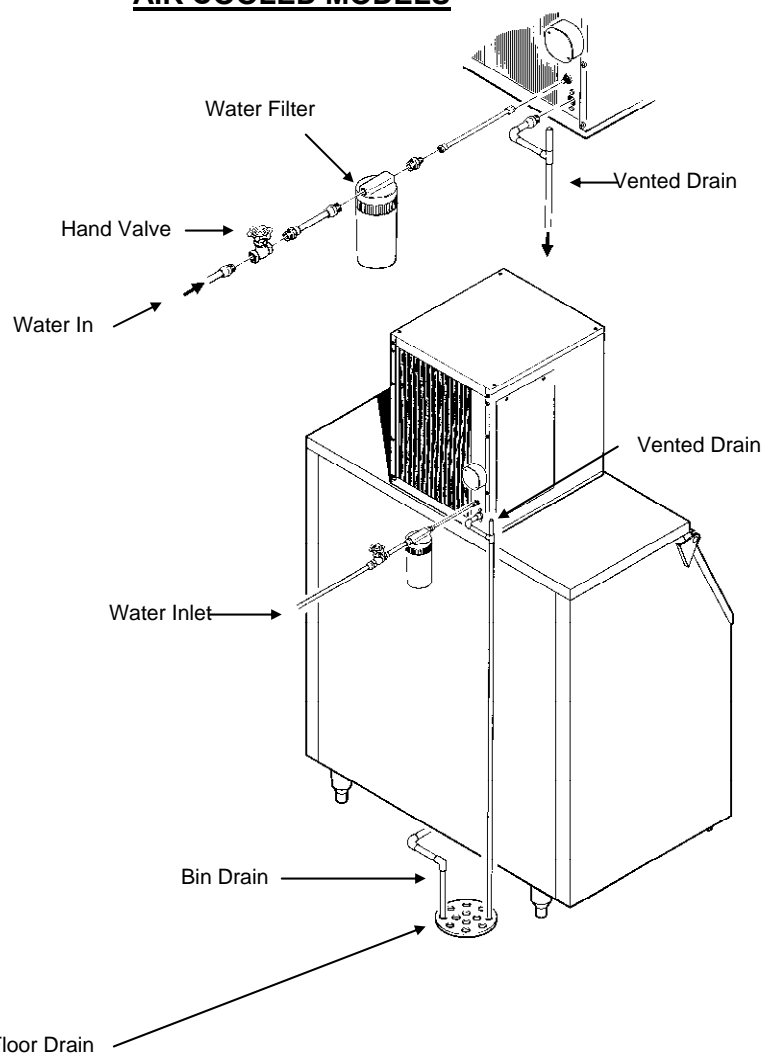

Water Inlet:**•Remote Cooled Models:**

The recommended water supply is cold water. Use 3/8 inch O.D. copper tubing, connect to the 3/8 FPT on the back of the cabinet. Install a hand valve near the machine to control the water supply.

Drains:**•Remote Cooled Models:**

There is one 3/4 inch FPT drain at the back of the cabinet; the drain line is of the gravity type, and 1/4 inch per foot fall is an acceptable pitch for the drain tubing. There should be a vent at the highest point of the drain line, and the ideal drain receptacle would be a trapped and vented floor drain. Use only 3/4 inch rigid tubing.

Storage Bin:

Install a separate gravity type drain. Insulation of this drain line is recommended.

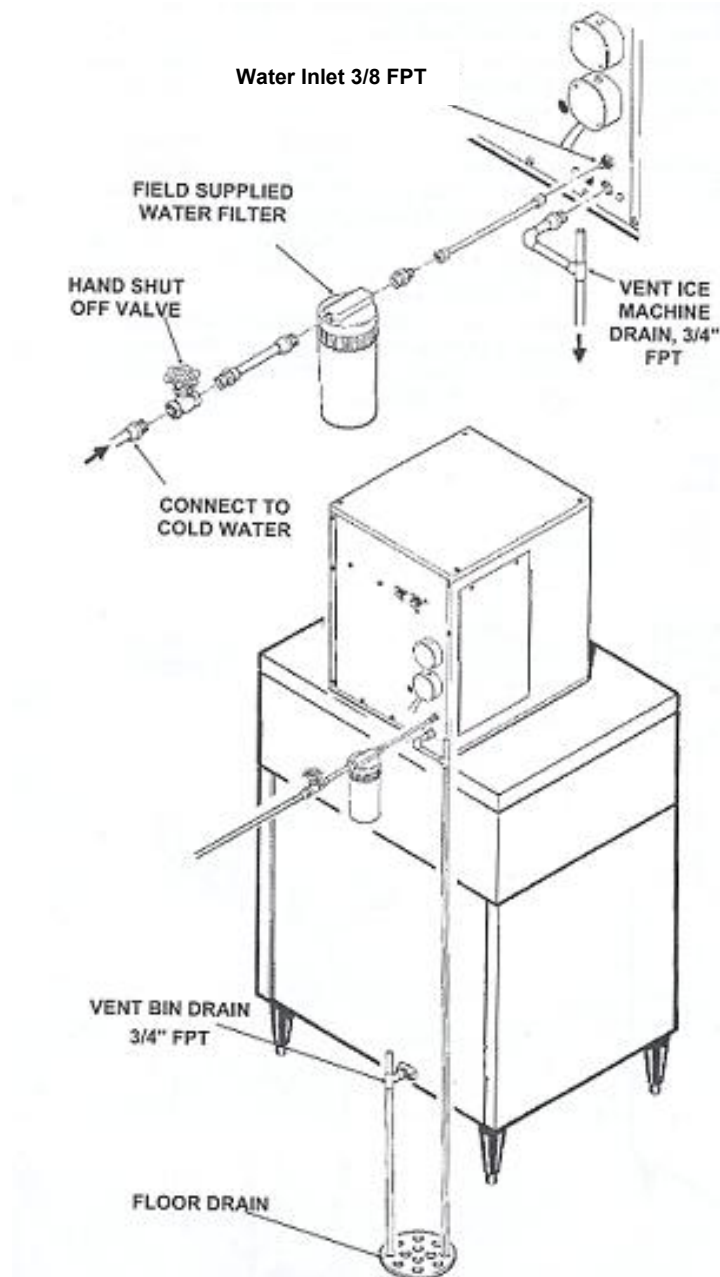

Electrical Connections:

Check the ice machine nameplate (located on the back panel) for the voltage requirements, and minimum circuit ampacity. The ice machine requires a solid chassis to earth ground.

Connect the ice machine to its own electrical circuit so it is individually fused. Voltage variation must remain within the limitations, even under starting conditions.

**Note: All external wiring must conform to national, state and local electrical codes.
The use of a licensed electrician is required to perform the electrical installation.**

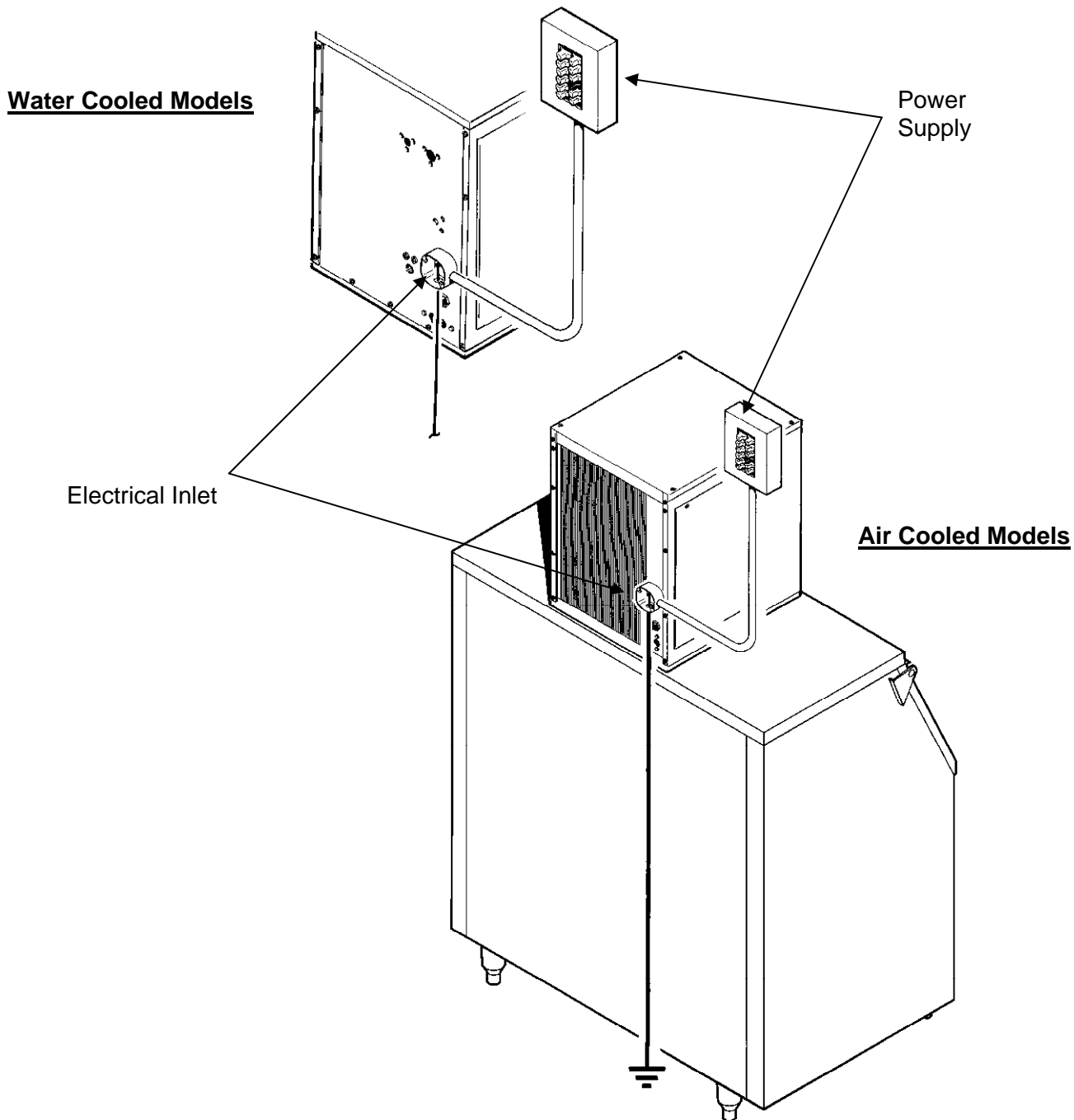

INSTALLATION MUST CONFORM TO ALL APPLICABLE CODES.

Connect the electrical power to the unit to the wires in the junction box at the rear of the machine. Check the nameplate (located on the back panel) for the voltage requirements, and for the minimum circuit ampacity. The machine requires a solid chassis to earth ground wire.

Connect the ice machine to its own electrical circuit so it is individually fused. Voltage variation must remain within design limitations, even under starting conditions.

There is a separate junction box for the remote condenser fan motor. Install an interconnecting wire between the remote condenser and the junction box at the back of the ice machine.

The remote condenser must be wired to the ice machine in accordance with local and national electrical codes with a minimum of 18 AWG. wire with a ground bonding wire connected to the ground screw provided in both the condenser and machine field wiring boxes. All outdoor wiring must be in rainproof conduit.

All external wiring must conform to national, state and local electrical codes. The use of a licensed electrician is required to perform the electrical installation.

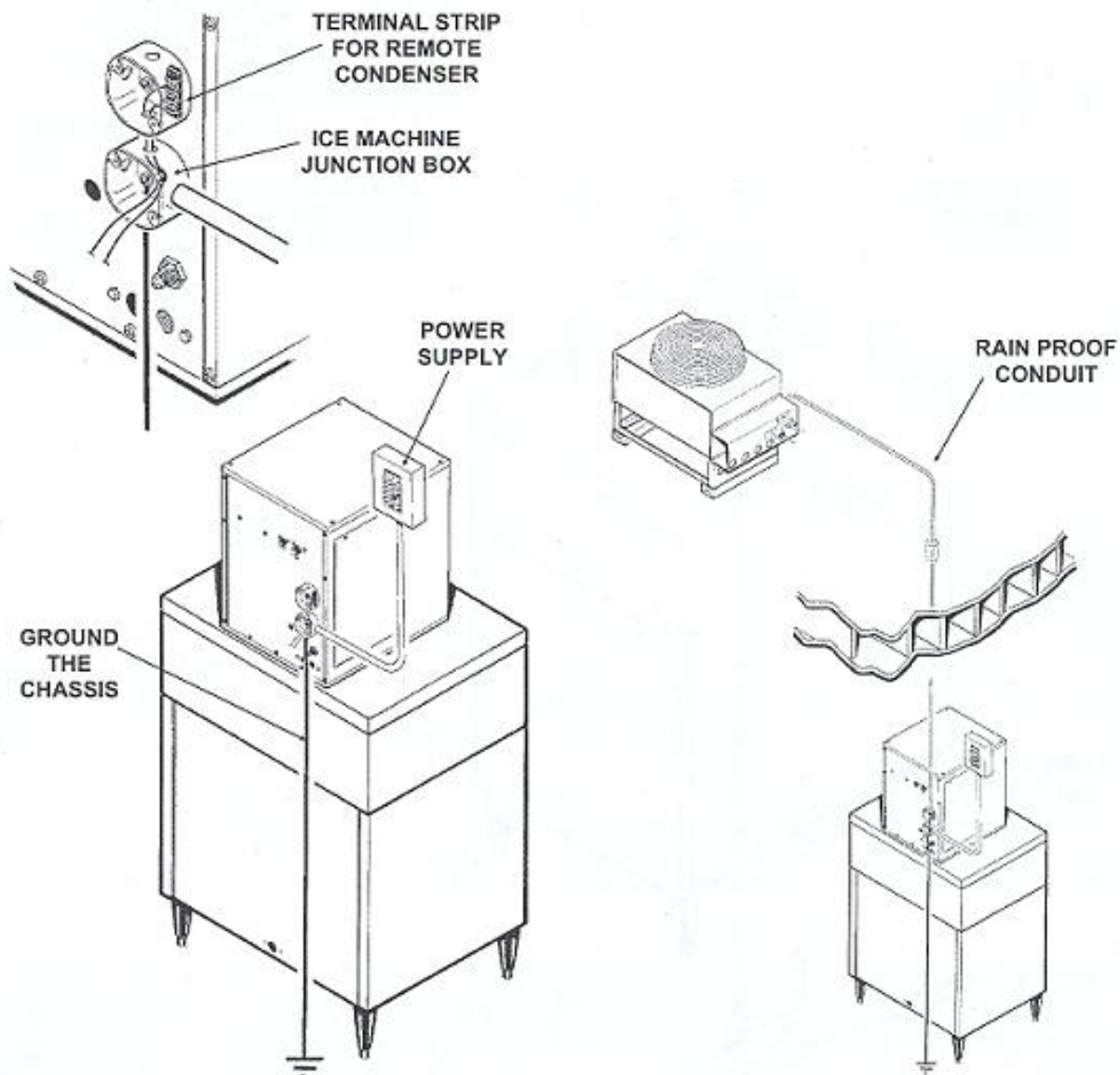

Completed Installation-Remote Condenser

A typical installation should generally appear as illustrated below. The best place for the remote condenser is above the ice machine, although other locations are permissible.

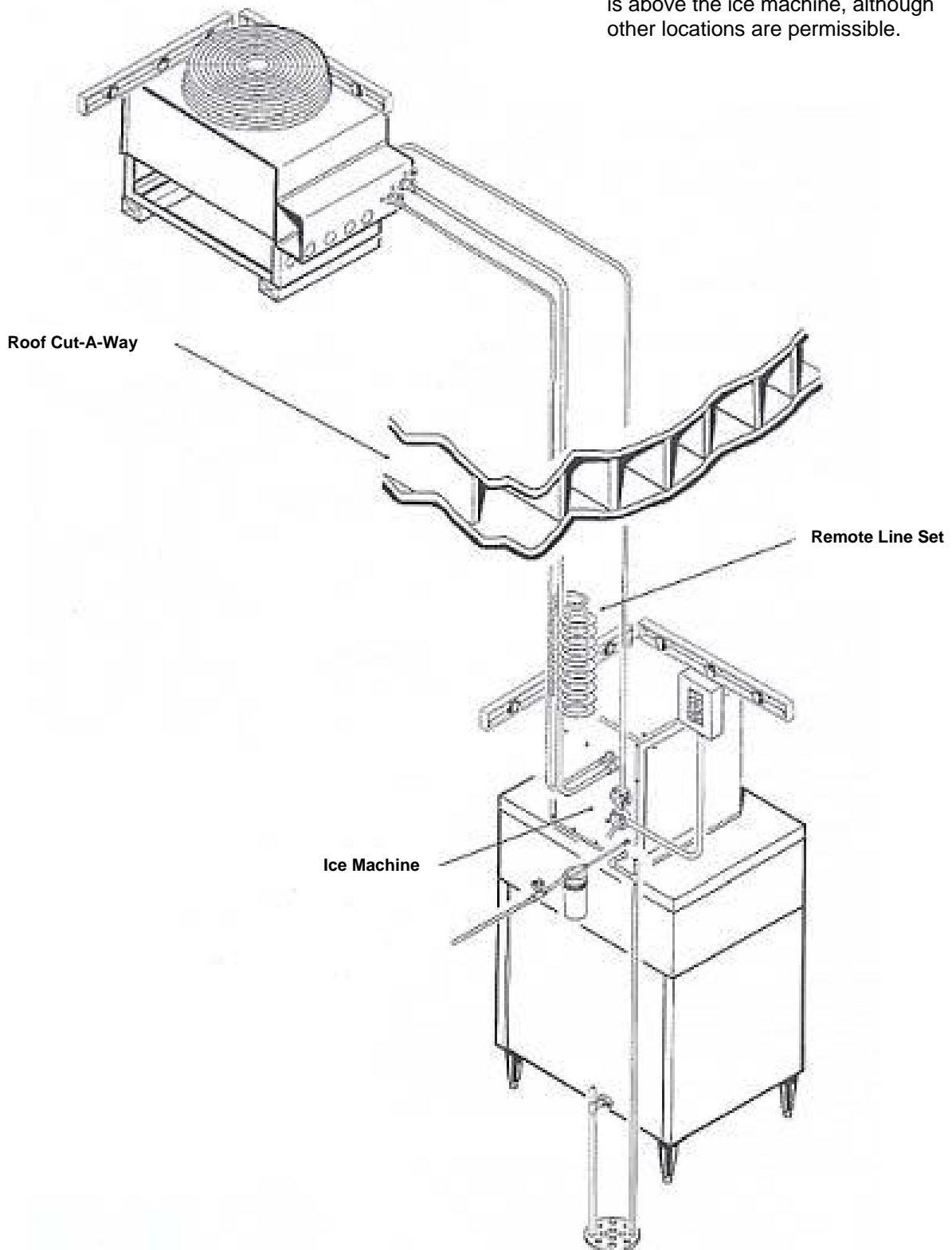

Final Check List: Air and Water Cooled

- ____ 1. Is the ice machine installed indoors in a location where the air and water temperatures are controlled and where they do not exceed the design limitations?
- ____ 2. Is there an electrical service disconnect within sight of the installed machine?
- ____ 3. Has the voltage been checked and compared to the nameplate requirements?
- ____ 4. Have all the plumbing connections been made and checked for leaks?
- ____ 5. Is the ice machine and storage bin level?
- ____ 6. Is there a minimum of 6 inches of clearance at the back of the machine for proper service access and air circulation?
- ____ 7. Is the water pressure a minimum of 20 psig?
- ____ 8. Has the ice machine been secured to the bin?
- ____ 9. Is there clearance over the top of the ice machine for service access?
- ____ 10. Is there a water shut off valve installed near the ice machine?

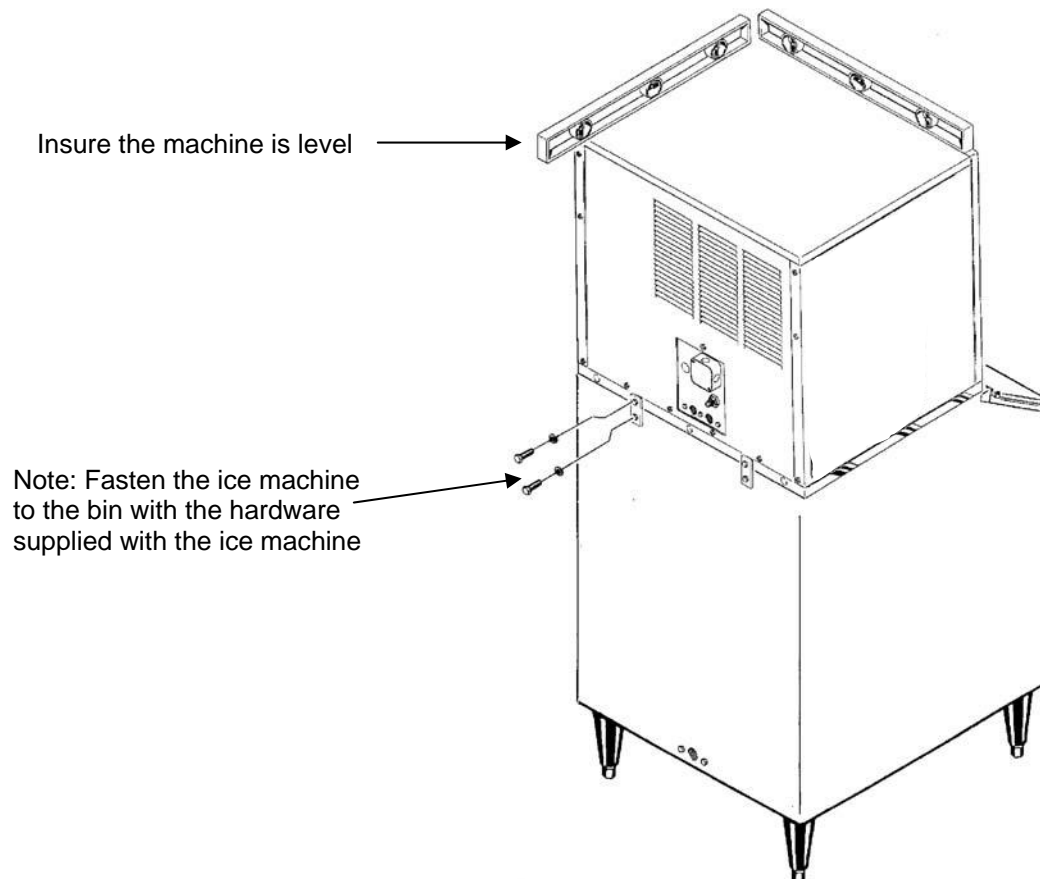

Final Check List: Remote

- 1. Is the ice system installed indoors in a location where air and water temperatures are controlled, and where they do not exceed the design limitations?
- 2. Is there an electrical service within sight of the installed machine? Has the voltage been checked, and compared to nameplate requirements?
- 3. Have all the plumbing connections been made and checked for leaks?
- 4. Has the machine and bin been leveled?
- 5. Is there a minimum of 6 inches clearance at the rear, left and right of the machine for proper service access?
- 6. Is the water pressure a minimum of 20 psig?
- 7. Has the machine been secured to the bin or dispenser?
- 8. Is there a water shut off valve installed near the machine?
- 9. Is the remote condenser installed per local codes, and in a place where it has adequate ventilation and minimal solar heat gain?
- 10. Has all shipping material and literature (inside front panel) been removed from the units?
- 11. Have the remote condenser and pre-charged lines been properly installed?
- 12. Has the electrical connection between the ice maker and condenser been made?
- 13. Verify that the master switch is in the OFF position.
- 14. Switch ON the electrical power.
- 15. Refer to the Pre-Start instructions

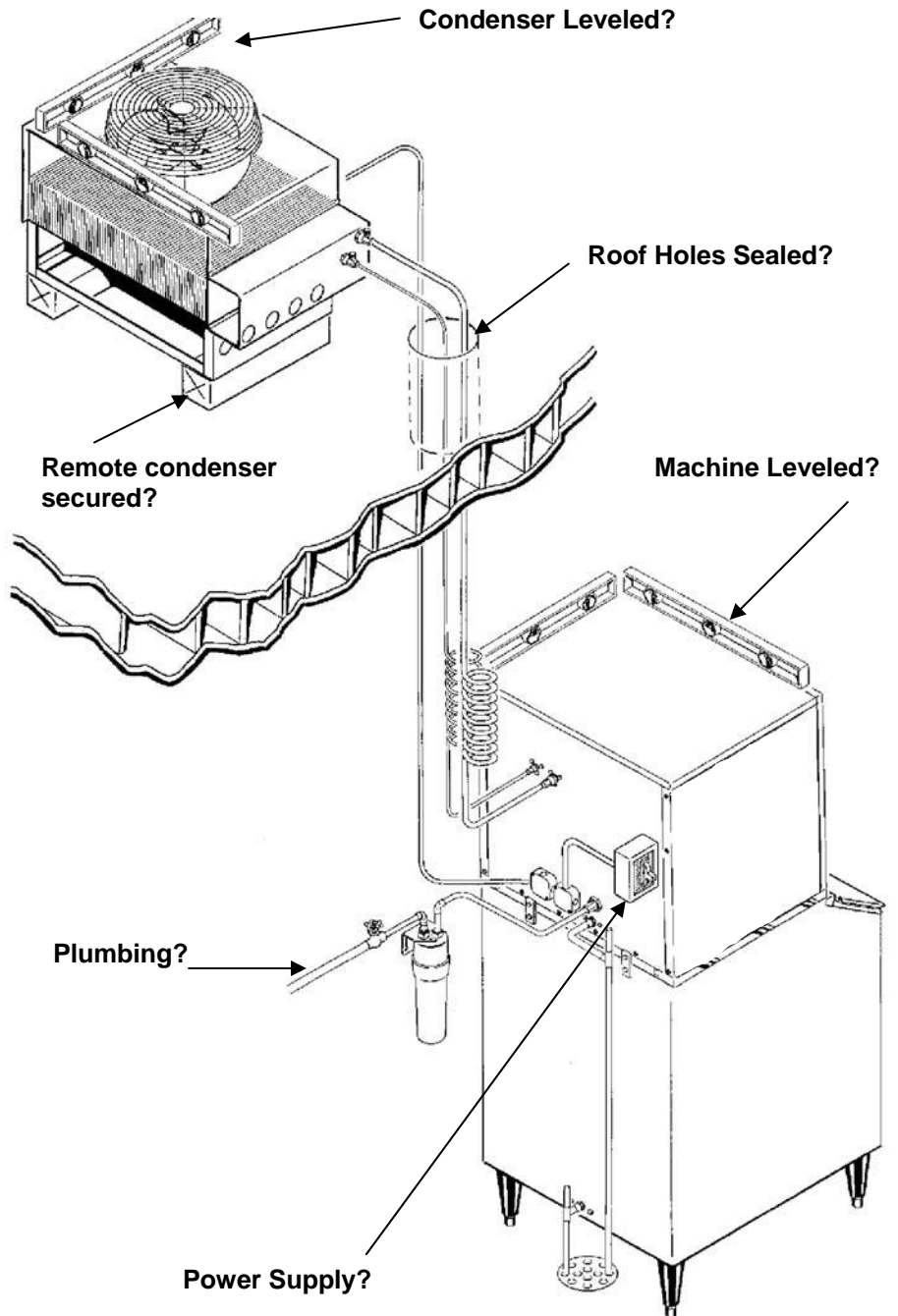

Pre-Start Inspection: Air and Water Cooled

1. Remove the front and side service panels.
2. Check that any shipping blocks have been removed.
3. Inspect the interior of the ice machine for loose screws or wires.
4. Check that no refrigerant lines are rubbing each other.
5. Check that the fan blades turn freely (Air Cooled).
6. Check that the unit is installed correctly according to the final check list.

Start Up:

1. Go through the pre-start inspection.
2. Open the hand valve, observe that water enters the water reservoir, fills the tube from the water reservoir to the evaporator and then shuts off. (Water cooled only, Turn the water supply **ON** to the water cooled condenser). Check for leaks.
3. Switch the master (mode) switch **ON**. The electrical start up sequence in automatic.
 - a. There should be a short (15 second) delay before the gear motor starts.
 - b. After the gear motor starts, the compressor will start.
4. On air cooled models, the condenser will begin to discharge warm air, on water cooled models, the water regulating valve will open and warm water will be discharged into the drain.
5. The unit should soon be making ice, if desired; the low side pressure may be checked: it should be 32 psig +/- 2 psig.

The suction line temperature at the compressor is normally very cold, nearly to the point of frost up to the compressor body, but not on it.

The air cooled discharge pressure will depend upon air and water temperatures, but should be between 200 psig and 280 psig.

The water cooled discharge pressure should be a constant at about 245 psig.

Note: The above pressures are for new, clean machines. You can expect to see some values higher, and some lower between different units.
6. **There are no adjustments to make**, so replace the panels.
7. Clean and/or sanitize the storage bin interior, wipe off the exterior with a clean, damp cloth.
8. Give the owner/user the service manual, instruct him/her in the operation of the unit, and make sure they know who to call for service.
9. Fill out the manufacturer's registration and mail it to Ice-O-Matic.

Pre-Start Inspection: Remote

1. Remove the front and side service panels.
2. Check that any shipping blocks have been removed.
3. Inspect the interior of the ice machine for loose screws or wires.
4. Check that no refrigerant lines are rubbing each other.
5. Check that the fan blades turn freely (Remote Condenser).
6. Check that the refrigerant lines are properly installed.
7. Check that the electrical power has been on for at least 4 hours and that the compressor dome is warm.
8. Check that the unit is installed correctly according to the final check list.

Start Up:

1. Go through the pre-start inspection.
2. Open the hand valve, observe that water enters the water reservoir, fills the tube from the water reservoir to the evaporator and then shuts off. (Water cooled only, Turn the water supply **ON** to the water cooled condenser). Check for leaks.
3. Open the King Valve.
4. Switch the master switch **ON**. The electrical start up sequence is automatic.
 - a. There should be a short (15 second) delay before the gear motor starts and the liquid line opens.
 - b. After the liquid line opens, the low pressure control will close and the compressor will start.
5. The remote condenser fan turns, and the condenser begins to discharge warm air.
6. The unit should soon be making ice, if desired; the low side pressure may be checked: it should be 32 psig +/- 2 psig.
The air cooled discharge pressure will depend upon air and water temperatures, but should be between 200 psig and 280 psig.
7. **There are no adjustments to make**, so replace the panels.
8. Clean and/or sanitize the storage bin interior, wipe off the exterior with a clean, damp cloth.
9. Give the owner/user the service manual, instruct him/her in the operation of the unit, and make sure they know who to call for service.
10. Fill out the manufacturer's registration and mail it to Ice-O-Matic.

ICE Machine and/or Bin/Dispenser Cleaning and Sanitizing Instructions

Cleaning should be scheduled at a minimum of twice per year.

Sanitizing should be performed after each cleaning or more frequently as required.

Note: Electrical power will be ON when performing the following cleaning instructions.

The cleaning and sanitizing of any commercial ice machine are important procedures all operators need to have in their preventive maintenance protocol. While similar, these two procedures are uniquely different and accomplish different things. Cleaning or de-liming, dissolves the mineral deposits on the evaporator and removes scale, calcium and other mineral buildup. Sanitizing disinfects the machine and removes microbial growth including mold and slime.

In either case, it is important to use solutions that do not harm the ice machine. Never use cleaning or sanitizing solutions that contain Nitric Acid, Sulfuric Acid, Hydrochloric Acid, Carboric Acid, Acetic Acid, diluted Acetic Acid or non-food-grade vinegar (concentration of acetic acid greater than 6% and does not contain enzymes created in processing) or any chlorine-based solution such as bleach, chlorine dioxide or any type of salts such as potassium chloride (potassium salts) or sodium chloride. Check the label or the manufacturer's Material Safety Data Sheet (MSDS) to be sure. These chemicals can attack the surface of the evaporator as well as other metal components causing corrosion and flaking. Reverse Osmosis (RO) water can be very acidic and can attack the evaporator and other metal in the ice machine. Because the RO process removes all minerals and metals from the water it can promote the faster growth of microbial, mold and slime. If RO water is used, Ice-O-Matic recommends the water pH is verified to be a neutral 7.0 to minimize the corrosive effects. Incorrect cleaners, sanitizers, and RO water that does not have a neutral pH could void the machine's warranty.

Cleaning

Prior to Cleaning the ice machine and/or Bin/Dispenser, perform the following:

1. Remove the ice machine front panel.
2. Turn the machine "OFF" at the **ON/OFF** selector switch.
3. Remove all ice in the storage bin. (**Required for cleaning and/or sanitizing**)

Cleaning Instructions-Ice Machine

1. Remove the cover from the water reservoir and block up the float.
2. Drain the water reservoir and freezer assembly using the drain tube attached to the freezer water inlet. Return the drain tube to its normal position and replace the end cap.
3. Add recommended amount of approved nickel safe ice machine cleaner (diluted per manufacturer's instructions) to the water trough. (Reference cleaner Manufacturer's instructions on the package)
4. Slowly pour the cleaning solution into the water reservoir until full. Wait 15 minutes, then switch the **ON/OFF** switch to the **ON** position.
5. As the ice machine begins to use water from the reservoir, continue to add more cleaning solution to maintain a full reservoir.
6. After all of the cleaning solution has been added to the reservoir, and the reservoir is nearly empty, switch the **ON/OFF** switch to the **OFF** position.
7. Drain the water reservoir and freezing assembly using the drain tube attached to the to the freezer water inlet. Return the drain tube to its normal position and replace the drain plug end cap. Wash and rinse the water reservoir.
8. **Sanitizing the Ice Machine is required after cleaning per Sanitizing Instructions**

Cleaning Instructions-Storage Bin/ Dispenser

1. Open the bin door and remove all of the ice in the storage bin, store the ice in a clean container for reuse or discard.
2. Add recommended amount of approved nickel safe ice machine cleaner (diluted per manufacturer's instructions) (Reference cleaner Manufacturer's instructions on the package)
3. Thoroughly wash all surfaces within the bin, this includes the bin door, bin walls, window track and snout area with soap and water and rinse. Note: An extended handle soft bristle brush may be required.
4. Allow the mineral deposits to absorb the cleaner for approximately 15 minutes to remove and loosen the mineral deposits. Note: This includes the bin drain.
5. Thoroughly wash all surfaces within the bin, this includes the bin door, bin walls, window track and snout area with soap and water and rinse. Note: Repeat Steps 3, 4 and 5 as required.
6. **Sanitizing the Storage Bin/Dispenser is required after cleaning per Sanitizing Instructions**

Sanitizing

Prior to Sanitizing the ice machine and/or Bin/Dispenser, perform the following:

1. Remove the ice machine front panel.
2. Turn the machine “OFF” at the **ON/OFF** selector switch.
3. Turn **OFF** the potable water supply to the ice machine.
4. Remove all ice in the storage bin. (**Required for cleaning and/or sanitizing**)

Sanitizing Instructions-Ice Machine

1. Use an EPA approved food equipment sanitizer at the solution mix recommended by the sanitizer manufacturer.
2. Slowly pour the sanitizer solution into the water reservoir until full. Wait 15 minutes, then switch the **ON/OFF** switch to the **ON** position.
3. As the ice machine begins to use water from the reservoir, continue to add more sanitizing solution to maintain a full reservoir.
4. After all of the sanitizing solution has been added to the reservoir, and the reservoir is nearly empty, switch the **ON/OFF** switch to the “OFF” position.
5. Drain the water reservoir and freezing assembly using the drain tube attached to the to the freezer water inlet. Return the drain tube to its normal position and replace the drain plug end cap. Wash and rinse the water reservoir. During this time, wipe down all other ice machine splash areas. Inspect to insure that water transport system components are in the correct position.
6. Place the **ON/OFF** switch to the “ON” position and replace the front panel.
7. Continue ice making for at least 15 minutes to flush out any cleaning or sanitizing solution.
8. **Remove and discard all ice in the storage bin. DO NOT USE any ice produced from the cleaning solution.**

Sanitizing Instructions- Bin/ Dispenser

1. Use an EPA approved food equipment sanitizer at the solution mix recommended by the sanitizer manufacturer.
2. Sanitize the bin interior, this includes the bin door, bin walls, window track and snout area with an approved sanitizer using the directions for that sanitizer. Note: This includes the bin drain.
3. **Remove and discard all ice in the storage bin. DO NOT USE any ice produced from the cleaning solution.**

Common Questions**•Ice-O-Matic Ice Machine/Bin Cleaning**

Cleaning or de-liming an ice machine refers to the process of removing mineral buildup and scale from the evaporator and other components. Ice-O-Matic recommends cleaning the ice machine at least every 6 months. More frequent cleaning may be needed depending on water quality and filtration system used. It is the responsibility of the operator to determine the optimal frequency for their particular environment. Cleaning will not remove microbial, mold, or slime. The machine should always be sanitized after cleaning.

Ice-O-Matic recommends a “nickel-safe” cleaner such as Nu-Calgon or equivalent. Typically the chemical composition is as follows:

- Water 53% to 82%
- Phosphoric Acid 15% to 40%
- Citric Acid 3% to 7%



WARNING

Ice Machine Cleaner contains acids.
KEEP OUT OF THE REACH OF CHILDREN
Refer to ice machine cleaner manufactures
emergency instructions on container label.

Ice-O-Matic recommends cleaning be done by a trained technician and that they follow detailed steps as prescribed in the Technical Service Manual.

Most cleaners list in their instructions an ounces to a gallon mixture for proper level of solution. Pouring undiluted cleaner directly into the machine will not give proper dilution level. Ice-O-Matic recommends mixing in a plastic container before pouring into trough.

•Ice-O-Matic Ice Machine/Bin/Dispenser Sanitizing

Ice-O-Matic recommends sanitizing or disinfecting an ice maker a minimum of every six months. More frequent sanitizing may be needed if the machine is in a high yeast environment or if RO water is being used. It is the responsibility of the operator to determine the optimal frequency for their particular environment.

Ice-O-Matic recommends an EPA approved sanitizer such as Nu-Calgon IMS-II or equivalent. Sanitizing is a simple matter of running the EPA approved sanitizer through the ice machine/bin/dispenser and wiping down surfaces with the sanitizer. If being done at the same time as the cleaning process, sanitizing must be done after the cleaning process. Follow the process as prescribed in the Owner’s Manual. Note: this process requires the ice be removed from the bin.

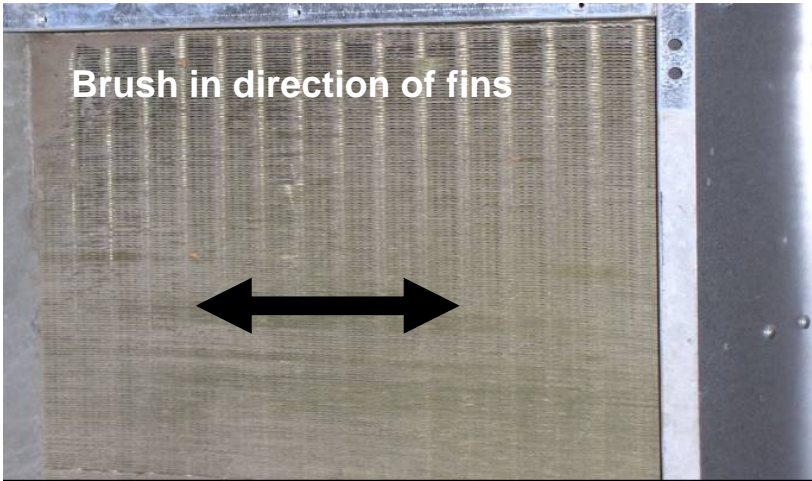

- Clean the condenser: the condenser may appear to be clean on the surface, but it can still be clogged internally. Check with a flashlight from the front to see if light can be seen through the condenser fins.

The condenser coil must be kept clean. The condenser can be cleaned with compressed air or by using a brush.

If a brush is used, brush in the direction of the fins taking care not to bend or distort the fins. Use a soft bristle nylon brush.

If the condenser fins are bent or distorted, this will restrict the airflow through the condenser and the fins will need to be straightened with a fin comb.

When cleaning the Condenser, check the fan blade for cleanliness and for balance. Balance is checked by spinning the blade by hand and looking for any wobble. Pull on the shaft in several directions to check the bearings of the motor.

The fins of the remote condenser require periodic cleaning.

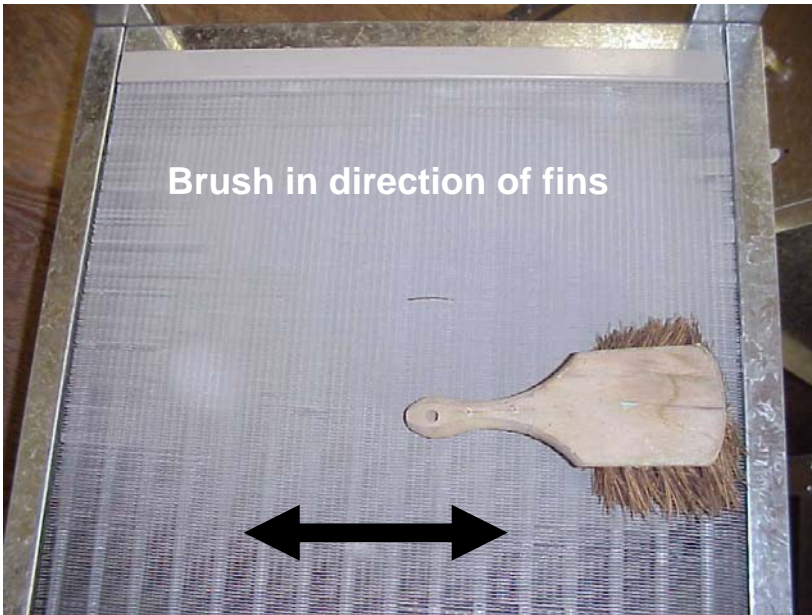

At 6 month intervals the fins on the inlet side of the condenser (bottom as shown) should be brushed free of dust and dirt. Brush in the direction of the fins as noted by the arrows.

Additionally look through the fins, using a flashlight if required, to insure there is no other blockage obstructing air flow between the fins.

If the air flow appears to be blocked, blow out the condenser using CO2 gas.

Caution: Disconnect electrical power before servicing this equipment.

Caution: Protective eye wear and gloves should be worn when cleaning the condenser.

Clean the air cooled condenser:

Air flow on this model is from front to back, so the inside of the ice machine will have to be available to clean the air cooled condenser. Use a vacuum cleaner or coil cleaner if needed. **DO NOT** use a wire brush.

- **Disconnect electrical power**, and remove the air filter if applicable. The filter may be cleaned or replaced.
- Clean the condenser: the condenser may appear to be clean on the surface, but it can still be clogged internally. Check with a flashlight from the front to see if light can be seen through the condenser fins.

GEM0956

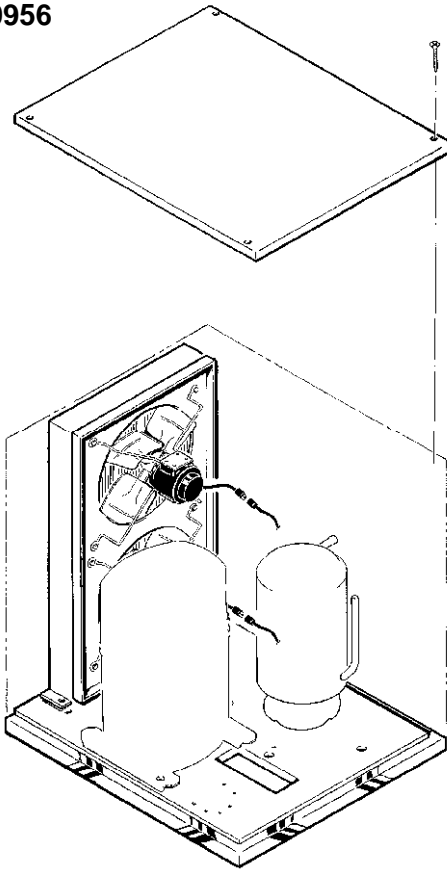

- Step 1. Remove the Top Panel
- Step 2. Remove two screws and unplug fan motors.
- Step 3. Pull fan motor assembly up and to the right to remove.
- Step 4. Clean the condenser.

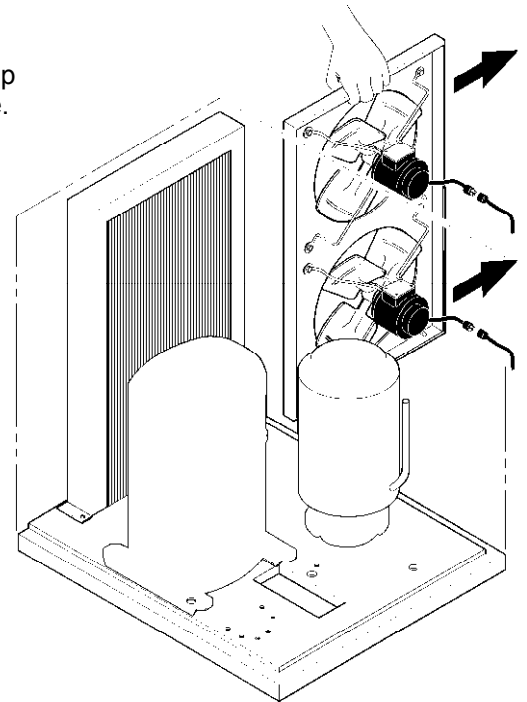

GEM0650

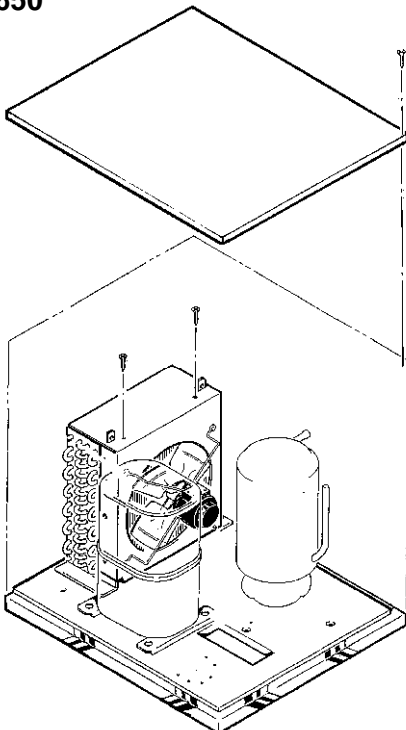

- Step 1. Remove the Top Panel
- Step 2. Remove the top portion of the fan shroud.
- Step 3. Clean the condenser.

