

Instruction Sheet

Subject: Installations Instructions

Air Compressor Kits

Important

Read the following warnings before beginning an installation. Failure to do so may result in possible death or serious injury.

⚠ Warning

To Avoid Serious Injury

- DO** Adhere to all National and Local Plumbing and Electrical Safety Codes.
- DO** Turn "off" incoming electrical service switches when servicing, installing, or repairing equipment.
- DO** Check that all flare fittings on the carbonation tank(s) are tight. This check should be performed with a wrench to ensure a quality seal.
- DO** Inspect pressure on regulators before starting up equipment.
- DO** Protect eyes when working around refrigerants.
- DO** Use caution when handling metal surface edges of all equipment.
- DO** Handle CO₂ cylinders and gauges with care. Secure cylinders properly against abrasion.
- DO** Store CO₂ cylinder(s) in well ventilated areas.
- DO NOT** Throw or drop a CO₂ cylinder. Secure the cylinder(s) in an upright position with a chain.
- DO NOT** Connect the CO₂ cylinder(s) directly to the product container. Doing so will result in an explosion causing possible death or injury. It is best to connect the CO₂ cylinder(s) to a regulator(s).
- DO NOT** Store CO₂ cylinders in temperature above 125°F (51.7°C) near furnaces, radiator or sources of heat.
- DO NOT** Release CO₂ gas from old cylinder.
- DO NOT** Touch refrigeration lines inside units. Some may exceed temperatures of 200°F (93.3°C).

Important

Water pipe connections and fixtures directly connected to a potable water supply shall be sized, installed and maintained in accordance with Federal, State, and Local codes.

⚠ Warning

Danger of Electric Shock

Disconnect and lock out all electrical power sources before performing service or maintenance on this machine — except when electrical tests are being performed by qualified service personnel.

Air Compressor Kit with Change-over Valve and Dump Valve — P.N. 00212135 (120 VAC), P.N. 00214969 (120 VAC), P.N. 00217555 (230 VAC)

These instructions cover the installation and initial start-up of the Multiplex Air Compressor Kit. An appropriate 3-wire, 15 amp power receptacle must be provided within 5 ft (152.4 cm) of the left end of the refrigeration unit. This kit is for use with either the Model 44 or Model 50 Fountain Refrigeration Units and any of the Beermaster Units. Refer to appropriate section for instructions.

GROUNDING INSTRUCTIONS

This product should be grounded. In the event of an electrical short circuit, grounding reduces the risk of electric shock by providing an escape wire for the electric current. This product is equipped with a cord having a grounding wire with an appropriate grounding plug. The plug must be plugged into an outlet that is properly installed and grounded in accordance with all local codes and ordinances.

⚠ DANGER

Improper installation of the grounding plug can result in a risk of electric shock. If repair or replacement of the cord or plug is necessary, do not connect the grounding wire to a flat blade terminal. The wire with insulation having an outer surface that is green with or without yellow stripes is the grounding wire.

Check with a qualified electrician or serviceman if the grounding instructions are not completely understood, or if in doubt as to whether the product is properly grounded. Do not modify the plug provided; if it will not fit the outlet, have the proper outlet installed by a qualified electrician. Do not use an extension cord or an adapter plug with this equipment.

FOUNTAIN SYSTEMS APPLICATIONS

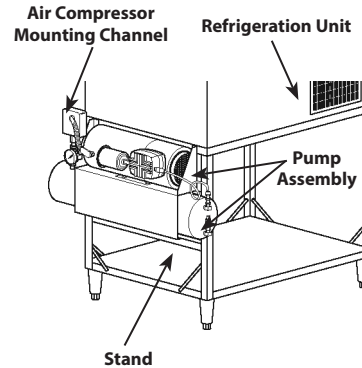

Mounting the Air Compressor onto a Multiplex Support Stand

Installing the air compressor onto the support stand

1. Mount the air compressor mounting channel to left end of the Multiplex Support Stand with two (2) 1/4"-20 nuts and screws provided with kit (refer to figure above).

NOTE: Compressor may be mounted to the end of the refrigeration unit.

2. Install the air compressor assembly to the support stand and mounting channel with four (4) 1/4"-20 nuts and screws provided with kit (refer to figure above).

NOTE: Do not plug in pump assembly at this time. Shut "off" the main CO₂ supply to refrigeration unit.

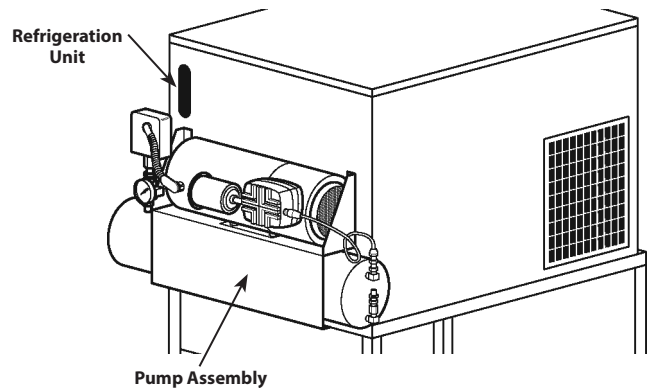

Mounting the Air Compressor onto a Multiplex Refrigeration Unit

Installing the air compressor onto a refrigeration unit

1. Align the air compressor assembly over the four (4) holes on left end of the Multiplex Refrigeration Unit. Secure to unit using the four (4) 1/4" screws provided in kit (refer to figure above).

NOTE: Do not plug in pump assembly at this time. Shut "off" main CO₂ supply to refrigeration unit.

2. Locate the Air/CO₂ Change-over Valve Assembly supplied with kit (P.N. 00212506). Align the mounting bracket of the change-over valve over the mounting holes on the control panel (location for change-over valve will be marked "Air/CO₂ Change-over Valve"). Mount the air/co₂ change-over valve to the panel with the #10-32 screws provided in kit (refer to figure below).

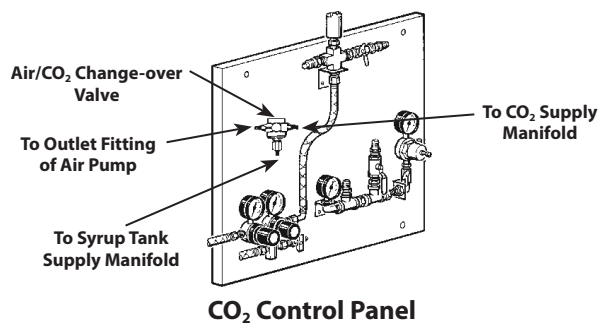

CO₂ Control Panel

Installing the optional dump valve onto the Multiplex refrigeration unit

1. Connect the 1/4" line assembly provided in kit (P.N. 00212506) to the flare fitting on right side of air/CO₂ change-over valve. Route the other end of tubing to the CO₂ supply manifold. Trim excess line and connect swivel nut adapter to the remaining end of line assembly. Secure with tab clamp. Connect the line assembly to the CO₂ supply manifold (refer to figure below).

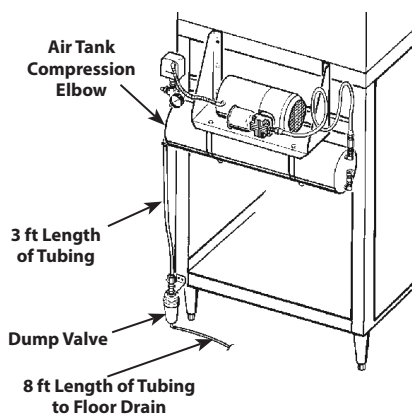

Mounting the Dump Valve onto the Multiplex Refrigeration Unit

2. Locate the 4-1/2" section of 1/4" tubing connected at bottom side of change-over valve. Route and connect the remaining end of tubing to the syrup tank supply manifold (refer to figure above).
3. Locate the 12 ft x 1/4" EVA line assembly provided in air compressor kit. Attach the end of this line assembly, with the swivel nut, to the outlet fitting of the air compressor tank. Use 1/4" flare washers at swivel nut connectors. Neatly route tubing under the stand top and to the left side of the control panel. Connect the line assembly with 1/4" elbow x barb (provided in kit P.N. 00212506) to the 1/4" male flare fitting of the air/CO₂ change-over valve (refer to figure above).
4. Locate the dump valve supplied with kit. Mount the dump valve with #10-32 self-tapping screws provided with kit to lower left cross channel of support stand.
5. Locate the 3 ft length of tubing supplied with kit. Neatly route and attach this line from the air tank compression elbow to the shut-off valve compression fitting located on top of the dump valve. Trim tubing to correct length. Tighten compression nuts.
6. Locate the 8 ft length of tubing supplied with kit. Route and connect this line from the 1/4" barb elbow of the dump valve to a floor drain. Place the shut-off valve handle in the "open" position (refer to figure above).
7. Plug the air pump power supply cord into the power receptacle provided on wall. Pump will begin to run immediately and shut "off" when tank pressure reaches approximately 90 psi (6.2 bar). Pump will turn "on" when tank pressure drops to 70 psi (4.8 bar). If not, adjust pressure switch according to instructions located on the inside of pressure switch cover.
8. Turn the air/CO₂ change-over valve to the "Air" position. Check for leaks.

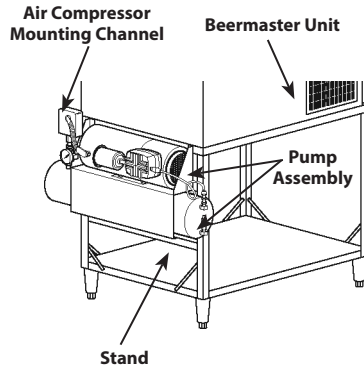
BEER SYSTEMS APPLICATIONS

Mounting the Air Compressor onto the Beermaster™ Unit
Procedure for installing the air compressor onto a Beermaster™ unit

1. Determine location where the air pump will be installed.

NOTE: Install the air compressor wall mount bracket (if applicable).

2. Install the air compressor in its final location with proper hardware.
3. Mount the low pressure regulator (packed separately) to a convenient location. Attach the 10 ft x 1/4" ID air line (provided with air compressor) to the air pump outlet fitting. Route and connect the remaining end of the air line to the inlet and onto the outlet of the low pressure regulator. Route and connect the remaining end of the tubing to the inlet side of the air filter assembly.

4. Connect one (1) end of the remaining section of the air line to the outlet side of the air filter assembly. Route and connect the opposite end of the air line to the incoming air connection on the left side of the blender.
5. Attach the 10 ft x 3/8" ID drain line to the tank drain fitting and route opposite end to floor drain.
6. Close tank outlet valve and plug air compressor into a 120 VAC outlet (domestic).

NOTE: Allow tank to fill completely and shut "off". Compressor should shut "off" at approximately 70 psi (4.8 bar). Compressor will start up when tank pressure drops to approximately 50 psi (3.1 bar).

7. Open tank outlet valve and adjust air compressor regulator to 40 psi (2.8 bar).

Air Pump & Tank with Change-over Valve & Dump Valve Kit — P.N. 00212145 (220V), P.N. 00214971 (220V)

These instructions cover the installation of the 220V/50Hz Multiplex Air Pump kit. This kit is designed to be used with Model 37KX and Model 44KX. The air pump must be mounted to the support stand with a minimum of a 6-inch clearance.

1. Mount air compressor mounting channel to left side of stand in the third hole down with two 1/4-20 nuts and screws provided with kit. (See figure below)
2. Install pump/tank assembly to stand and mounting channel with four 1/4-20 nuts and screws provided with kit. (See figure below)

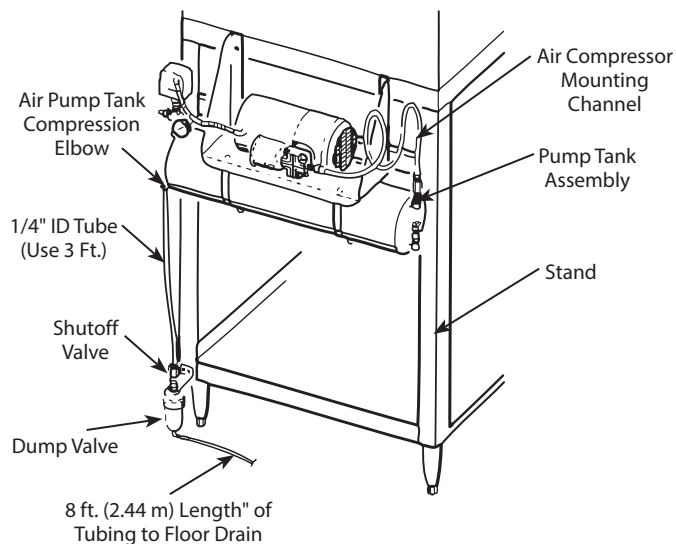

Installation

INSTALLATION OF MODEL 37KX REFRIGERATION UNIT

1. Shut off main CO₂ supply to refrigeration unit.
2. Open the CO₂ control panel door on the refrigeration unit and locate the 3/8" O.D. (9.5 mm) white polyethylene tubing that is routed between the carbonator tank CO₂ supply manifold and the syrup tank CO₂ supply manifold (see figure below). Remove and discard this section of tubing.

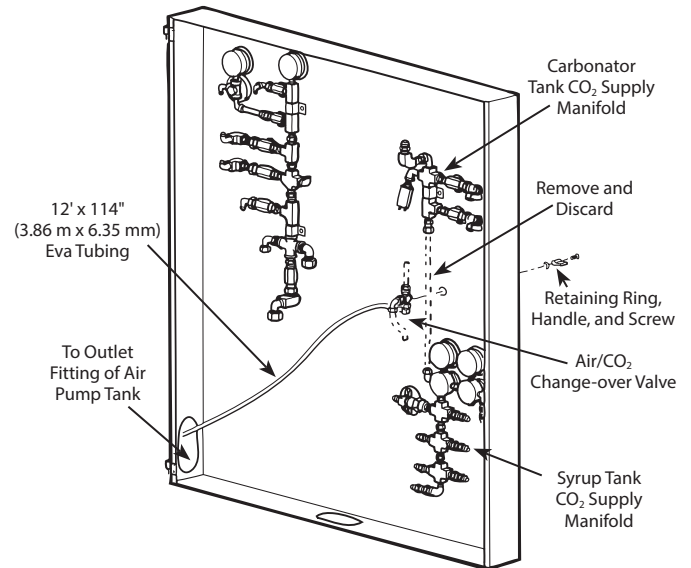

Model 37KX Manifolds

3. Locate the air/CO₂ change-over valve supplied with the air pump installation kit (P.N. 212508 Provided with Stand). Remove the change-over valve handle, screw, and retainer ring. Install the change-over valve in the hole provided in the control panel marked "Air/CO₂ Change-over Valve". Replace the retainer ring, valve handle, and screw. (See figure above)
4. Attach the upper 3/8" O.D. (9.5 mm) white polyethylene tubing of the CO₂ change-over valve to the carbonator tank CO₂ supply manifold. Attach the lower 3/8" O.D. (9.5 mm) white polyethylene tubing of the CO₂ change-over valve to the syrup tank CO₂ supply manifold. Use compression nuts supplied with kit. (See figure above)

NOTE: Turn air/CO₂ change-over valve handle to the "CO₂" position.

5. Locate the 12' x 1/4" EVA (3.66 meters x 6.35 mm) tubing supplied with air compressor. Attach the end of this line assembly with the swivel nut to the outlet fitting of the air compressor tank. Neatly route tubing under the stand top, up through the opening in lower right end of control panel and attach the opposite end of this line assembly to the 1/4" (6.35 mm) barb elbow of the air/CO₂ change-over valve previously installed in the control panel. Trim excess line as necessary. Use two tab clamps to hold tube on stem. (See figure above)
6. Locate the dump valve supplied with air compressor. Mount the dump valve with #10-32 self-tapping screws provided with kit to lower left cross channel of support stand. Use holes provided in channel. (See Installation figure)

7. Locate the three foot (0.91 m) length of tubing supplied with air compressor. Neatly route and attach this line from the air compressor tank compression elbow to the shutoff valve compression fitting located on top of the dump valve. Trim tubing to correct length.
8. Locate the eight foot (2.44 m) length of tubing supplied with air compressor. Route and connect this line from the 1/4" (6.35 mm) barb elbow of the dump valve to a floor drain. Place the shut-off valve handle in the open position. (See Installation figure)
9. Connect the air pump to the outlet box, following the electrical instructions below.

INSTALLATION OF MODEL 44KX REFRIGERATION UNIT

1. Shut off main CO₂ supply to refrigeration unit.
2. Locate the air/CO₂ change-over valve assembly supplied with kit P.N. 212506. Align the mounting bracket of the change-over valve over the mounting holes on control panel (Location for changeover valve will be marked "Air/CO₂ Change-over Valve"). Mount the air/CO₂ change-over valve to the panel with the #10-32 screws provided in kit. (See figure below)

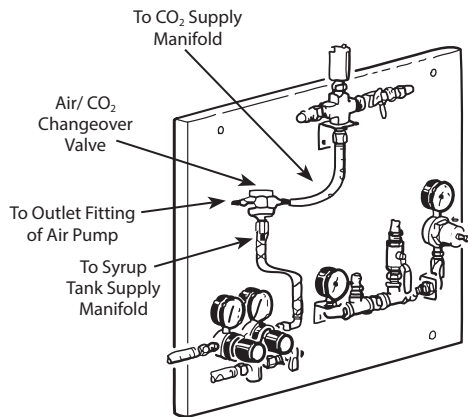

Model 44KX Manifolds

3. Locate the 1/4" (6.35 mm) EVA line connected at the CO₂ supply manifold and syrup tank manifold. Remove and discard the line.
4. Connect the 1/4" (6.35 mm) line assembly provided in kit P.N. 212506 to the flair fitting on the right side of the air/CO₂ change-over valve. Route the other end of the tubing to the CO₂ supply manifold. Trim excess line and connect swivel nut adapter to the remaining end of line assembly. Secure with tab clamps. Connect this line assembly to the CO₂ supply manifold. (See figure above)

5. Locate the 4-1/2" (11.4 cm) section of 1/4" (6.35 mm) tubing and connect to the bottom side of the air/CO₂ change-over valve. Route and connect the remaining end of tubing to the syrup tank supply manifold. (See figure above)
6. Locate the 12' x 1/4" (3.66 m x 6.35 mm) EVA line assembly provided in kit P.N. 212506. Attach the end of this line assembly, with the swivel nut, to the outlet fitting of the air compressor tank. Neatly route tubing under the stand top and to the left side of the control panel. Connect the line assembly with 1/4" (6.35 mm) elbow x barb (provided in kit P.N. 212506) to the 1/4" (6.35 mm) male flare fitting of the air/CO₂ change-over valve. (See figure above)
7. Locate the dump valve supplied with kit. Mount the dump valve with #10-32 self-tapping screws provided with kit to lower left cross channel of support stand. Use holes provided in channel. (See Installation figure)
8. Locate the six foot (1.83 m) length of tubing supplied with kit. Neatly route and attach this line from the air compressor tank compression elbow to the shutoff valve compression fitting located at top of the dump valve. Trim tubing to correct length. (See Installation figure)
9. Locate the eight foot (2.44 m) length of tubing supplied with kit. Route and connect this line from the 1/4" (6.35 mm) barb elbow of the dump valve to a floor drain. Place the shutoff valve handle in the open position. (See Installation figure)
10. Connect the cord to the stand outlet box or the wall outlet, following the appropriate steps listed below.

ELECTRICAL CONNECTIONS (FOR BOTH MODELS 37KX AND 44KX)

This air pump kit is designed to easily connect to the high stand that supports the refrigeration unit Model 44KX or 37KX. The stand comes with an electrical outlet box mounted to it. However, should the pump be used with another type of stand, the power cord must be modified by adding a plug that is accepted by the local electric outlet.

CONNECTING THE AIR PUMP TO THE STAND OUTLET BOX

⚠ Warning

Before proceeding with this installation, make sure the power to this box is disconnected.

1. Locate the outlet box under the stand. Open the cover of the outlet box.
2. Remove one of the 1/2" dia. knock-outs on the side or bottom of the box.
3. Route the loose end of pump cord and terminals through the Romex connector, the box wall opening, and then the Romex connector lock-nut. Tighten the connector and lock-nut securely against the box wall.
4. Connect the brown wire to the open terminal available on the switch labeled "Air compressor" as shown on the wiring diagram below. Connect the blue wire to the other two blue wires inside the box that are already connected with wire-nut terminal.
5. "Ground" the pump to the unit using the ground screw available on box and the green wire.
6. Replace the box cover and tighten the holding screws securely.

CONNECTING THE AIR PUMP TO THE WALL OUTLET

An appropriate 3-wire power receptacle must be available within 6 feet from the intended operating location of the air pump kit. A locally furnished plug must be attached to the power cord in order to be accepted by the local electrical receptacle.

1. Locate a 3-wire plug. This plug (not furnished with kit) must have a ground-wire connecting terminal.
2. Locate the loose end of the power cord attached to the kit. All three wires are stripped to 1/2" length from the end.
3. Connect all three wires to plug using the 1/2" stripped ends or any other terminal requirements. Different plugs and terminals may require different stripped lengths.

4. Check cord and plug connection for any loose or bare wires.

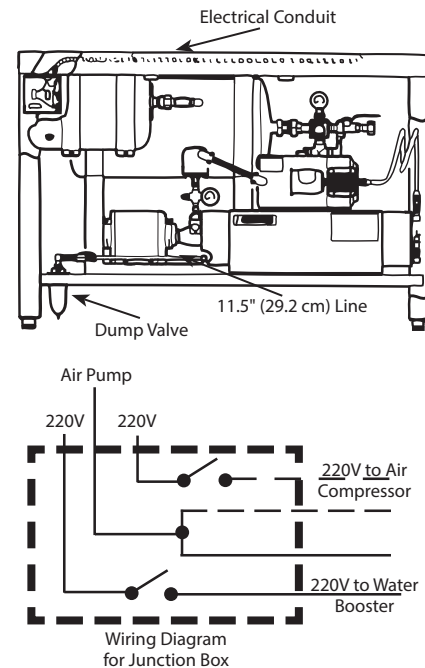

⚠ Warning

To avoid the risk of electrical shock, the installer must check the following:

This pump kit must be grounded. In the event of an electrical short circuit, grounding reduces the risk of electrical shock by providing an escape wire for the electrical current. This product is equipped with a grounding-type cord. To reduce the risk of electrical shock, be certain that the plug and cord are securely assembled and that they are used only with a properly grounded receptacle. Check with a qualified electrician or serviceman if the grounding instructions are not completely understood.

Do not use an extension cord or an adapter plug with this equipment. Do not splice the furnished power cord to a locally supplied cord. If another power cord must be used, completely replace the existing cord with the new one. Proceed with the electric connection of the stand outlet box to the refrigeration unit electrical box using the stand installation instructions packed with the stand.

Air Tank Retro-fit Kit — P.N. 00212053

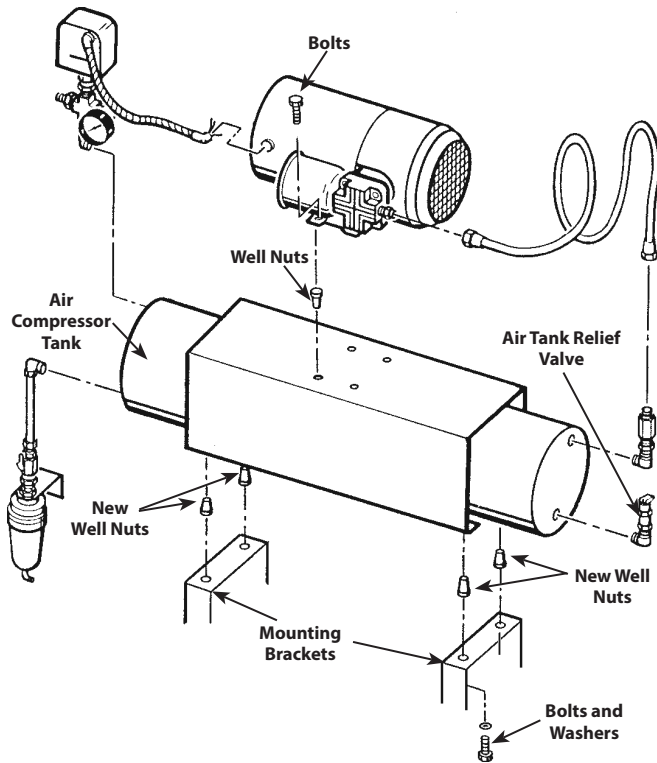

REMOVING OLD TANK

1. Push the switch labeled "Air Compressor" to the "off" position.
2. Open the air tank relief valve. Allow all air pressure to bleed from tank.
3. Remove the four (4) bolts holding the air compressor and motor assembly to the air compressor tank. Save for future step in these instructions.
4. Remove all lines and/or fittings from the old tank. Note the relative position of all fittings removed from the old tank, as they will be re-installed into the new tank in approximately the same position.
5. Remove the four (4) bolts and washers holding the air compressor tank legs to the compressor mounting brackets. Save these for a future step in these instructions.

INSTALLING THE NEW AIR COMPRESSOR TANK

1. Remove and discard the four (4) old well nuts from the stand's air compressor mounting brackets and replace with four (4) new well nuts, provided in kit (refer to figure).
2. Position the new air compressor tank on the mounting bracket. Fasten the tank to the mounting bracket with the four (4) bolts and washers previously removed from the old tank (refer to figure).
3. Install four (4) well nuts, provided in kit, into the holes on top of the air compressor tank's mounting bracket. Fasten the air compressor and motor assembly to the tank bracket with the four (4) bolts previously removed (refer to figure).
4. Attach all lines and fittings to the new stainless steel tank.

NOTE: Use Teflon tape on all fittings. Failure to use Teflon tape on all fittings will cause tank to leak.

START-UP

1. Push the switch labeled "Air Compressor" to the on position. The compressor motor should begin to run and will cycle "off" when the tank pressure reaches 85 psi (5.9 bar). If not, use instructions inside lid of pressure switch to adjust to proper settings.
2. When compressor cycles "off", check all connections for leaks.

Attaching Air Pump to Mounting Bracket — P.N. 00202676

OPENING THE CARTONS

Contents of Mounting Bracket carton:

- Mounting bracket
- Bag containing four (4) bolts, four (4) nuts, four (4) washers, four (4) 5-1/6 masonry lead anchors

Contents of the Multiplex Air Pump carton:

- Air pump
- Four (4) rubber mounting pads, four (4) bolts, and four (4) washers

INSTALLING THE MOUNTING BRACKET

1. Determine the most convenient location. Keep in mind the air pump will require periodic service.
2. To mount to a wall, four (4) lead anchors are provided to attach the bracket to a masonry wall. Any other means of attachment will have to be secured locally.

HOW TO ATTACH THE AIR PUMP TO THE MOUNTING BRACKET

1. Four (4) rubber mounting pads, bolts, and washers are provided for this purpose.
2. Insert the rubber pads into the holes in the bracket that match the holes in the air pump.
3. Position the air pump on the pads and screw in the bolts with washers. Tighten the bolts only enough to expand the rubber pads. This will secure the pump. Make sure you have taken into consideration servicing the air pump, the air tank, and the air filter.
4. Connect the air line from the control panel or manifold to 1/4" male flare fitting on the tank.
5. Make sure all connections are tight and that the air to the CO₂ Gas Change-over Valve is turned to "CO₂ Gas."
6. Plug the pump service cord into a 120V outlet. The pump should run and cycle "off" when the pressure gauge reaches 90 psi (6.2 bar). The pump should cycle "on" when the pressure drops to 70 psi (4.8 bar). If adjustments are necessary, remove the cover of the pressure control and follow instructions.

