

FOR QUALIFIED INSTALLER ONLY. This basic Installation Sheet is an initial release. If a complete Operations Manual (for the unit being installed) is required or needed, please refer to the Lancer web site (lancerworldwide.com) for immediate access, or for your convenience, scan this QR code with a mobile device (app required) for immediate access to other Technical Documents and alternative translations (if available) pertaining to this unit. Contact Lancer Customer Service for assistance as required.



ABOUT THIS MANUAL

This booklet is an integral and essential part of the product and should be handed over to the operator after the installation and preserved for any further consultation that may be necessary. Please read carefully the guidelines and warnings contained herein as they are intended to provide the user with essential information for the continued safe use and maintenance of the product. In addition, it provides **GUIDANCE ONLY** to the user on the correct services and site location of the unit.

BEFORE GETTING STARTED

Each unit is tested under operating conditions and is thoroughly inspected before shipment. At the time of shipment, the carrier accepts responsibility for the unit. Upon receiving the unit, carefully inspect the carton for visible damage. If damage exists, have the carrier note the damage on the freight bill and file a claim with carrier. Responsibility for damage to the dispenser lies with the carrier.

The installation and relocation, if necessary, of this product must be carried out by qualified personnel with up-to-date safety and hygiene knowledge and practical experience, in accordance with current regulations.

IMPORTANT SAFETY INSTRUCTIONS

⚠ Intended Use

The dispenser is for indoor use only. This unit is not a toy. Children should be supervised not to play with appliance. It should not be used by children or infirm persons without supervision. This appliance is not intended for use by persons (including children) with reduced physical, sensory or mental capabilities, or lack of experience and knowledge, unless they have been given supervision or instruction concerning use of the appliance by a person responsible for their safety. Cleaning and user maintenance shall not be performed by children without supervision. The min/max ambient operating temperature for the dispenser is 40°F to 90°F (4°C to 32°C). Do not operate unit below minimum ambient operation conditions. Should freezing occur, cease operation of the unit and contact authorized service technician. Service, cleaning and sanitizing should be accomplished only by trained personnel. Applicable safety precautions must be observed. Instruction warnings on the product being used must be followed.

⚠ Electrical Warning

Check the dispenser name plate label, located behind the splash plate, for the correct electrical requirements of unit. Do not plug into a wall electrical outlet unless the current shown on the serial number plate agrees with local current available. Follow all local electrical codes when making connections. Each dispenser must have a separate electrical circuit. Do not use extension cords with this unit. Do not 'gang' together with other electrical devices on the same outlet. The keyswitch does not disable the line voltage to the transformer primary. Always disconnect electrical power to the unit to prevent personal injury before attempting any internal maintenance. The resettable breaker switch should not be used as a substitute for unplugging the dispenser from the power source to service the unit. Only qualified personnel should service internal components of electrical control housing. Make sure that all water lines are tight and units are dry before making any electrical connections!

⚠ Carbon Dioxide (CO₂)

- **WARNING:** Carbon Dioxide (CO₂) is a colorless, noncombustible gas with a light pungent odor. High percentages of CO₂ may displace oxygen in the blood.
- **WARNING:** Prolonged exposure to CO₂ can be harmful. Personnel exposed to high concentrations of CO₂ gas will experience tremors which are followed by a loss of consciousness and suffocation.
- **WARNING:** If a CO₂ gas leak is suspected, immediately ventilate the contaminated area before attempting to repair the leak.
- **WARNING:** Strict attention must be observed in the prevention of CO₂ gas leaks in the entire CO₂ and soft drink system.



2200, 2300
23300, 2400

⚠ Water Notice

Provide an adequate potable water supply. Water pipe connections and fixtures directly connected to a potable water supply must be sized, installed, and maintained according to federal, state, and local laws. The water supply line must be at least a 3/8 inches (9.525 mm) pipe with a minimum of 25 psi (0.172 MPa) line pressure, but not exceeding a maximum of 50 psi (0.345 MPa). Water pressure exceeding 50 psi (0.345 MPa) must be reduced to 50 psi (0.345 MPa) with the provided pressure regulator. Use a filter in the water line to avoid equipment damage and beverage off-taste. Check the water filter periodically, as required by local conditions. The water supply must be protected by means of an air gap, a back-flow prevention device or another approved method to comply with NSF standards. A leaking inlet water check valve will allow carbonated water to flow back through the pump when it is shut off and contaminate the water supply. Ensure the back-flow prevention device complies with ASSE and local standards. It is the responsibility of the installer to ensure compliance.

SPECIFICATIONS

ICDI - 2200

DIMENSIONS

Width: 15.0 inches (381 mm)
Depth: 23 inches (584 mm)
Height: 33.38 inches (848 mm)

WEIGHT

Shipping: 130 lbs (59 kg)
Operating (w/ Ice): 166 lbs (75 kg)
Ice Capacity: 60 lbs (27.2 kg)

PLAIN WATER SUPPLY

Min Flowing Pressure: 20 psi (0.138 MPa)
Max Flowing Pressure: 50 psi (0.345 MPa)

COUNTER CUT-OUT

Width: 15.25 inches (387 mm)
Depth: 23.25 inches (591 mm)

ELECTRICAL

115 VAC / 60 Hz

CARBON DIOXIDE (CO₂) SUPPLY

Min Pressure: 90 psi (0.621 MPa)
Max Pressure: 110 psi (0.758 MPa)

This unit emits a sound pressure level below 70 dB

FITTINGS

Soda Water Inlet: 3/8 inch barb
Brand Syrup Inlets: 3/8 inch barb

ICDI - 2300

DIMENSIONS

Width: 23.0 inches (584 mm)
Depth: 23 inches (584 mm)
Height: 36.25 inches (921 mm)

WEIGHT

Shipping: 260 lbs (118 kg)
Operating (w/ Ice): 206 lbs (93 kg)
Ice Capacity: 100 lbs (45 kg)

PLAIN WATER SUPPLY

Min Flowing Pressure: 20 psi (0.138 MPa)
Max Flowing Pressure: 50 psi (0.345 MPa)

COUNTER CUT-OUT

Width: 23.25 inches (591 mm)
Depth: 23.25 inches (591 mm)

ELECTRICAL

115 VAC / 60 Hz

CARBON DIOXIDE (CO₂) SUPPLY

Min Pressure: 90 psi (0.621 MPa)
Max Pressure: 110 psi (0.758 MPa)

This unit emits a sound pressure level below 70 dB

FITTINGS

Soda Water Inlet: 3/8 inch barb
Brand Syrup Inlets: 3/8 inch barb

ICDI - 23300

DIMENSIONS

Width: 30.0 inches (762 mm)
Depth: 23 inches (584 mm)
Height: 35.25 inches (895 mm)

WEIGHT

Shipping: 300 lbs (136 kg)
Operating (w/ Ice): 370 lbs (168 kg)
Ice Capacity: 130 lbs (59 kg)

PLAIN WATER SUPPLY

Min Flowing Pressure: 20 psi (0.138 MPa)
Max Flowing Pressure: 50 psi (0.345 MPa)

COUNTER CUT-OUT

Width: 30.25 inches (768 mm)
Depth: 23.25 inches (591 mm)

ELECTRICAL

24 V / 60 Hz

CARBON DIOXIDE (CO₂) SUPPLY

Min Pressure: 90 psi (0.621 MPa)
Max Pressure: 110 psi (0.758 MPa)

This unit emits a sound pressure level below 70 dB

FITTINGS

Soda Water Inlet: 3/8 inch barb
Brand Syrup Inlets: 3/8 inch barb

ICDI - 2400 - Freestanding

DIMENSIONS

Width: 23 inches (584 mm)
Depth: 23 inches (584 mm)
Height: 54.20 inches (1377 mm)

COUNTER CUT-OUT

Width: 23.25 inches (591 mm)
Depth: 24 inches (603 mm)

This unit emits a sound pressure level below 70 dB

WEIGHT

Shipping: 196 lbs (89 kg)
Operating (w/ Ice): 290 lbs (132 kg)
Ice Capacity: 100 lbs (89 kg)

ELECTRICAL

24 VAC / 60 Hz

PLAIN WATER SUPPLY

Min Flowing Pressure: 20 psi (0.138 MPa)
Max Flowing Pressure: 50 psi (0.345 MPa)

CARBON DIOXIDE (CO₂) SUPPLY

Min Pressure: 90 psi (0.621 MPa)
Max Pressure: 110 psi (0.758 MPa)

FITTINGS

Soda Water Inlet: 3/8 inch barb
Brand Syrup Inlets: 3/8 inch barb

READ THIS MANUAL

This manual was developed by Lancer Worldwide as a reference for the owner/operator and installer of this dispenser. Please read this guide before installation and operation of this dispenser. If service is required please call your Lancer Service Agent or Lancer Customer Service. Always have your model and serial number available when you call.

Your Service Agent: _____

Service Agent Telephone Number: _____

Serial Number: _____

Model Number: _____

INSTALLATION

Unpack the Dispenser

1. Set shipping carton upright on the floor then cut package banding straps and remove.
2. Open top of carton and remove interior packaging.
3. Lift carton up and off of the unit.
4. Remove accessory kit and loose parts from ice compartment.

NOTE

Inspect unit for concealed damage. If evident, notify delivering carrier and file a claim against the same.

⚠ WARNING

To avoid personal injury or damage, do not attempt to lift a unit without help. For heavier units, use of a mechanical lift may be appropriate. Do not place hands, or foreign objects into the ice storage compartment. Unplug dispenser from the power source, when unit is being serviced, cleaned, or sanitized.

Selecting Counter Location

NOTE

The dispenser should only be installed in a location where it can be overseen by trained personnel

1. Select a level, well ventilated location that is in close proximity to a properly grounded electrical outlet, within five (5) feet (1.5 m) of a drain, a water supply that meets the requirements shown in the Specifications section found on pages 2-3, and away from direct sunlight or overhead lighting
2. The selected location should be able to support the weight of the dispenser and ice after the counter cut out is made. Total weight (with ice) for this unit could exceed 400 pounds (181.4 kg).
3. If installed directly on the counter, unit must be sealed to the counter-top with an FDA approved sealant.

NOTE

NSF listed units must be sealed to the counter or have four (4) inch legs installed.

4. Select a location for the remote carbonator, syrup pumps, pump deck, CO₂ tank, syrup containers, and water filter (recommended).

Dispenser Installation

NOTE

The installation, and relocation if necessary, must be carried out by qualified personnel with up-to-date knowledge and practical experience, in accordance with current regulations.

1. Inspect the counter location where the unit is to be installed then make counter cut-out, (See *Specifications* section on page 2 or images below for counter cut-out dimensions).

⚠ ATTENTION

Counter cut-out must be accurate, according to unit specifications.

2200 CUTOUT

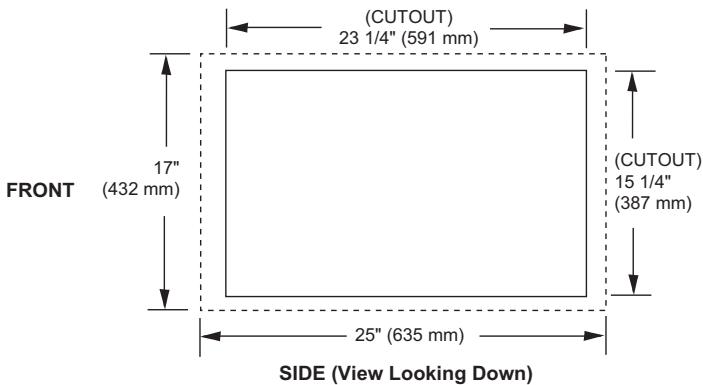

2323 CUTOUT

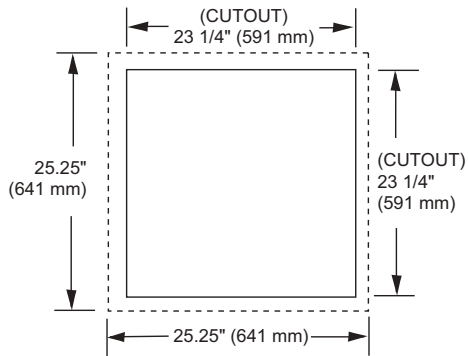

3023 CUTOUT

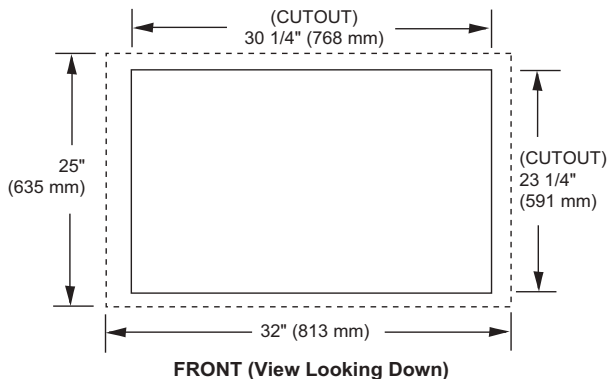

2. Once the counter cut-out is made, lower the unit into the counter and seal rim to the counter using an approved silicone sealant.

NOTE

Some of the units have shipping risers that can extend up to 23 inches (58.42 cm) below the counter, which Lancer recommends be left attached to the unit. Should the dispenser ever require removal, the shipping risers will protect the inlet tubes from being damaged.

3. Route appropriate tubing from the water source to the soda water inlet on the left of the unit and connect tubing to inlet using the oetiker pliers and fittings, (see Plumbing Diagrams on the front of the unit or on pages 8-9 for reference).

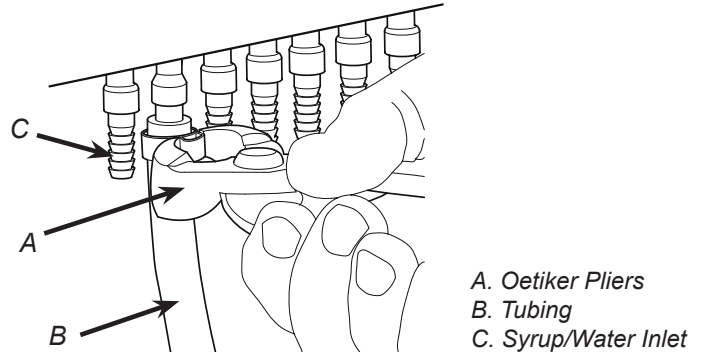

4. Connect tubing to water source then flush water lines to check for leaks.
5. Install water regulator and filter to water line and, if necessary, install water booster (Lancer PN MC-163172) between water supply and the unit.
6. Using tubing cutters, cut soda water line and install remote carbonator per manufacturer's specifications.
7. Install a shut-off valve in the water line feeding the carbonator pump deck.
8. Route appropriate tubing from the syrup pump location to the syrup inlets and connect tubing to all syrup inlets.
9. Route the power supply cord to a grounded electrical outlet of the proper voltage and amperage rating.

⚠ WARNING

DO NOT PLUG UNIT INTO GROUNDED ELECTRICAL OUTLET AT THIS TIME. Make sure that all water lines are tight and unit is dry before making any electrical connections

10. Route drain hose from designated open type drain to fitting below unit and connect hose to fitting.

⚠ CAUTION

Drain line must be insulated with a closed cell insulation. Insulation must cover the entire length of the drain hose, including fittings. The drain should be installed in such a manner that water does not collect in sags or other low points, as condensation will form.

⚠ ATTENTION

Pouring hot water down the drain may cause the Drain Tube to collapse. Allow only luke warm or cold water to enter the Drain Tube. Pouring coffee, tea, or other similar substances down the drain may cause the Drain Tube to become clogged.

Installing CO₂ Supply

1. Connect high pressure CO₂ regulator assembly to CO₂ cylinder or bulk system.

⚠ ATTENTION

Before installing regulator, assure that a seal (washer or o-ring) is present in regulator attachment nut.

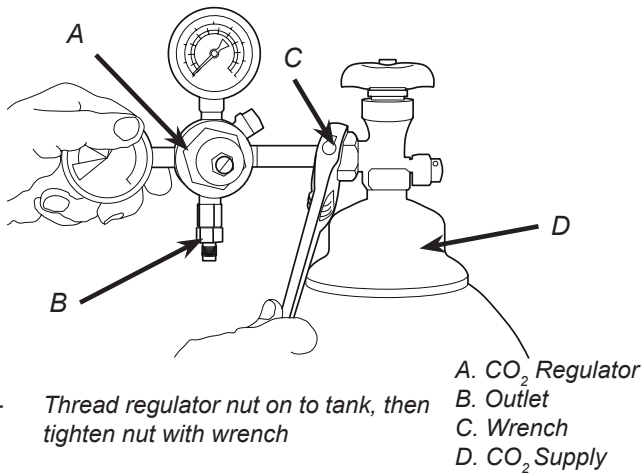

2. Connect a 1/4" nut, stem and seal to CO₂ regulator outlet.
3. Route tubing from the 1/4" nut, stem on the high pressure CO₂ regulator attached to low pressure regulator.

⚠ ATTENTION

A dedicated CO₂ regulator is required to supply the carbonator as well as to all syrup pumps.

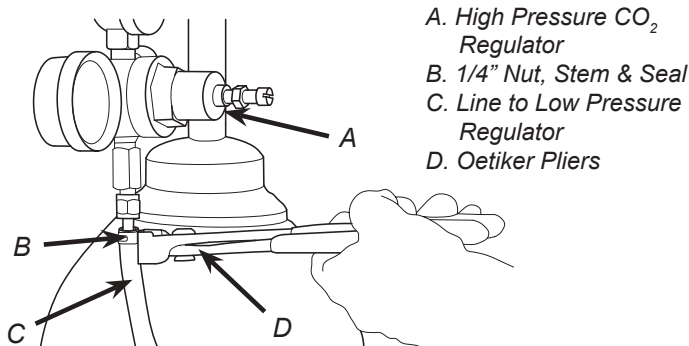

4. Route tubing from the remote carbonator to one of the low pressure CO₂ regulator manifold outlets.
5. Route tubing routed from the syrup pumps to the second outlet of the low pressure CO₂ regulator manifold.

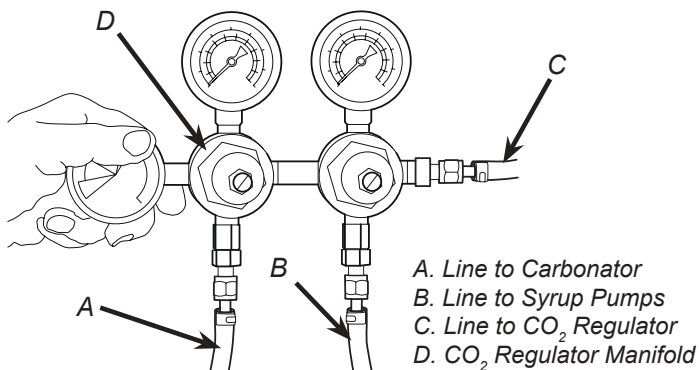

6. Using a wrench, loosen lock nut on the regulator adjustment screw of the high pressure CO₂ regulator connected to the source, then using a screwdriver back out lock nut screw all the way.

⚠ WARNING

DO NOT TURN ON CO₂ SUPPLY AT THIS TIME

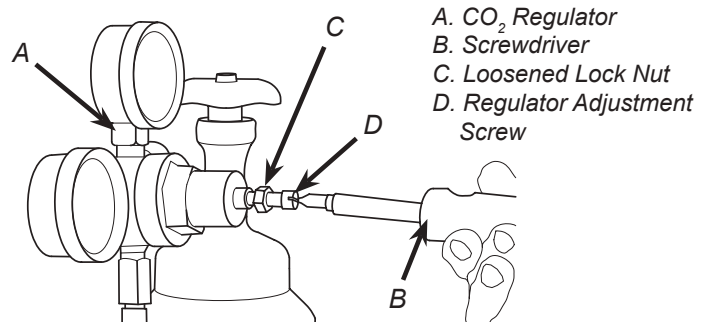

7. Repeat Step 6 for both low pressure CO₂ regulators on the regulator manifold routed to the carbonator and the syrup pumps.

Dispenser Setup

1. Install syrup pumps and syrup containers in designated location. Attach CO₂ line from the low pressure regulator to syrup pumps.
2. Attach CO₂ line from the low pressure regulator to gas inlet of remote carbonator.
3. Turn on water source.
4. Open the pressure relief valve, located on the remote carbonator, by flipping up on the valve cap lever. Hold open until water flows from the relief valve then close (flip down) the relief valve.
5. Verify all Bag-In-Box contains syrup and check all connections for leaks.
6. Place enough ice in the ice bin to fill approximately 1/2 of the bin before plugging in the unit.
7. Connect unit power cord to grounded electrical outlet.

⚠ WARNING

The dispenser must be properly electrically grounded to avoid serious injury or fatal electrical shock. The power cord has a three-prong grounded plug. If a three-hole grounded electrical outlet is not available, use an approved method to ground the unit. Follow all local electrical codes when making connections. Each dispenser must have a separate electrical circuit. Do not use extension cords. Do not connect multiple electrical devices on the same outlet.

8. Activate each valve to ensure a good flow of water is achieved.
9. Ensure pump deck is turned OFF before turning on CO₂.

⚠ ATTENTION

Failure to disconnect the motor power supply will damage the carbonator motor, the pump and void the warranty.

- Turn on CO₂ at the source then, using a screwdriver, adjust the high pressure regulator at the source to 110 psi (0.758 MPa) then tighten locknut with wrench.

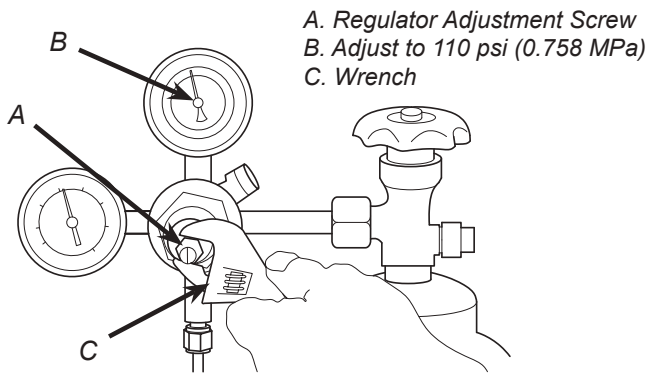

- Adjust both of the low pressure regulators on the regulator manifold to 75 psi (0.517 MPa) then tighten locknut with wrench.
- Activate each valve until gas-out.
- Plug in the remote carbonator pump deck, if not already done so, and turn the switch to the ON position.
- Activate each valve until the carbonator pump comes on. Release the button, allow carbonator to fill and stop. Repeat this process until a steady flow of carbonated water is achieved.

NOTE

The pump deck has a 3 minute timeout feature. If the timeout occurs, turn the deck OFF then ON by flipping the switch on the control box.

NOTE

To check for CO₂ leaks, close the valve on the CO₂ cylinder and observe if the pressure to the system drops with the cylinder valve closed for five minutes. Open the cylinder valve after check.

- Activate each valve to purge air from the syrup lines.

Adjust Water Flow Rate & Syrup/Water Ratio

NOTE

Ensure there is ice on the cold plate and the lines are cold before attempting to set the flow rates on the valves. The drink temperature should be no higher than 40°F (4.4°C) when flow rates are set.

- Remove valve cover from first valve.
- Close syrup shut-off at mounting block for first valve.

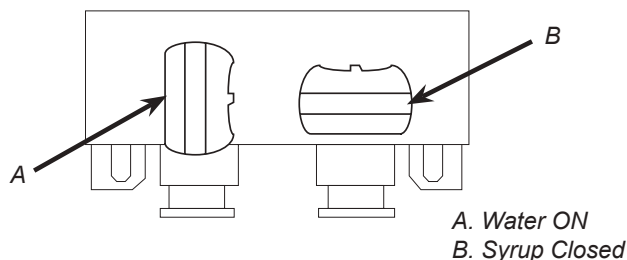

- Using a Lancer ratio cup verify water flow rate (5 oz. in 4 sec.). Use a screwdriver to adjust if needed.

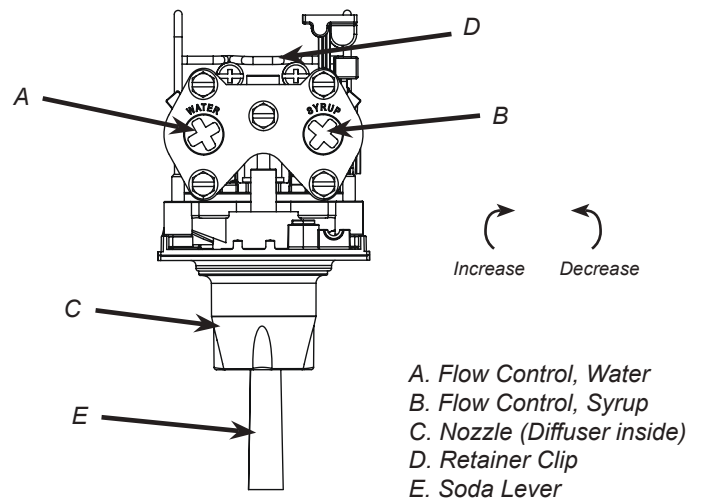

- Remove nozzle by twisting counter clockwise and pulling down, then remove diffuser by pulling down.
- Install Lancer (yellow) syrup separator (PN 54-0031) in place of nozzle.

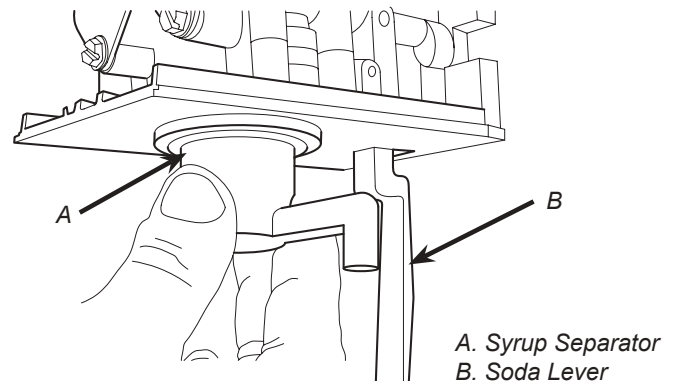

- Re-open syrup shut-off at mounting block.
- Activate valve to purge syrup until steady flow is achieved.
- Using a Lancer ratio cup, activate the valve and capture a sample. Verify that the syrup level is even with the water level. Use a screwdriver to adjust if needed.

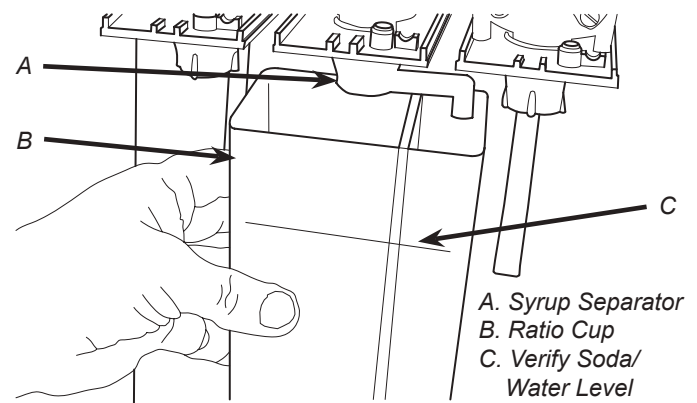

- Remove syrup separator and reinstall nozzle. Replace valve cover.
- Repeat steps 1-8 for each valve.
- Re-install merchandiser, splash plate, and top cover.

CLEANING AND SANITIZING

GENERAL INFORMATION

Lancer equipment (new or reconditioned) is shipped from the factory cleaned and sanitized in accordance with NSF guidelines. The operator of the equipment must provide continuous maintenance as required by this manual and/or state and local health department guidelines to ensure proper operation and sanitation requirements are maintained.

The cleaning procedures provided herein pertain to the Lancer equipment identified by this manual. If other equipment is being cleaned, follow the guidelines established by the manufacturer for that equipment.

Cleaning should be accomplished only by trained personnel. Sanitary gloves are to be used during cleaning operations. Applicable safety precautions must be observed. Instruction warnings on the product being used must be followed.

⚠ ATTENTION

- Use sanitary gloves when cleaning the unit and observe all applicable safety precautions.
- **DO NOT** use a water jet to clean or sanitize the unit.
- **DO NOT** disconnect water lines when cleaning and sanitizing syrup lines, to avoid contamination.
- **DO NOT** use strong bleaches or detergents; These can discolor and corrode various materials.
- **DO NOT** use metal scrapers, sharp objects, steel wool, scouring pads, abrasives, or solvents on the dispenser.
- **DO NOT** use hot water above 140° F (60° C). This can damage the dispenser.
- **DO NOT** spill sanitizing solution on any circuit boards. Insure all sanitizing solution is removed from the system.

Cleaning Solution

Mix a mild, non-abrasive detergent (e.g. Sodium Laureth Sulfate, dish soap) with clean, potable water at a temperature of 90°F to 110°F (32°C to 43°C). The mixture ratio is one ounce of cleaner to two gallons of water. Prepare a minimum of five gallons of cleaning solution. Do not use abrasive cleaners or solvents because they can cause permanent damage to the unit. Ensure rinsing is thorough, using clean, potable water at a temperature of 90°F to 110°F. Extended lengths of product lines may require additional cleaning solution.

Sanitizing Solution

Prepare the sanitizing solution in accordance with the manufacturer's written recommendations and safety guidelines. The type and concentration of sanitizing agent recommended in the instructions by the manufacturer shall comply with 40 CFR §180.940. The solution must provide 100 parts per million (PPM) chlorine (e.g. Sodium Hypochlorite or bleach) and a minimum of five gallons of sanitizing solution should be prepared.

⚠ WARNING

If a powder sanitizer is used, dissolve it thoroughly with hot water prior to adding to the syrup system. Ensure sanitizing solution is removed from the dispenser as instructed. Avoid getting sanitizing solution on circuit boards. Do not use strong bleaches or detergents; these can discolor and corrode various materials. Do not use metal scrapers, sharp objects, steel wool, scouring pads, abrasives, or solvents on the dispenser. Do not use hot water above 140° f (60° c). This can damage the dispenser.

Cleaning and Sanitizing Nozzles

1. Disconnect power, so as to not activate valve while cleaning.
2. Remove merchandiser to reveal valves.
3. Remove nozzle by twisting counter clockwise and pulling down.
4. Remove diffuser by pulling down.
5. Rinse nozzle and diffuser with warm water.
6. Wash nozzle and diffuser with cleaning solution then immerse in sanitizing solution and let sit for fifteen (15) minutes.
7. Set nozzle and diffuser aside and let air dry. **DO NOT** rinse with water after sanitizing.
8. Reconnect diffuser and nozzle.
9. Connect power.
10. Taste the drink to verify that there is no off-taste. If off-taste is found, flush syrup system again.

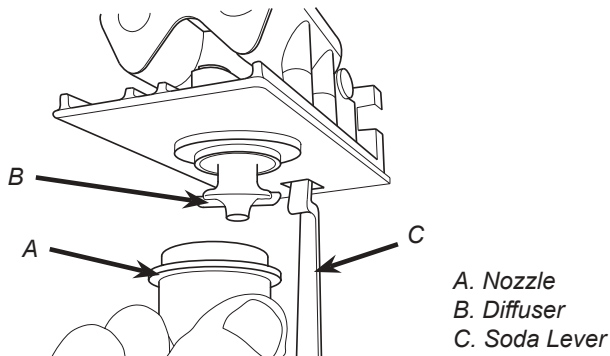

⚠ CAUTION

Following sanitation, rinse with end-use product until there is no aftertaste. Do not use a fresh water rinse. This is a NSF requirement. Residual sanitizing solution left in the system creates a health hazard.

Cleaning and Sanitizing Syrup Lines - Bag in Box

1. Disconnect syrup lines from BIB's
2. Place syrup lines, with BIB connectors, in a bucket of warm water.
3. Activate each valve to fill the lines with warm water and flush out syrup remaining in the lines.
4. Prepare Cleaning Solution described on previous page.
5. Place syrup lines, with BIB connectors, into cleaning solution.
6. Activate each valve until lines are filled with cleaning solution then let stand for ten (10) minutes.
7. Flush out cleaning solution from the syrup lines using clean, warm water.
8. Prepare Sanitizing Solution described on previous page.
9. Place syrup lines into sanitizing solution and activate each valve to fill with sanitizer. Let sit for ten (10) minutes.
10. Reconnect syrup lines to BIB's and draw drinks to flush solution from the dispenser.
11. Taste the drink to verify that there is no off-taste. If off-taste is found, flush syrup system again.

⚠ CAUTION

Following sanitation, rinse with end-use product until there is no aftertaste. Do not use a fresh water rinse. This is a NSF requirement. Residual sanitizing solution left in the system creates a health hazard.

Cleaning and Sanitizing Ice Bin Compartment

NOTE

The ice bin compartment of the dispenser should be thoroughly cleaned and sanitized at least once every month.

1. Prepare cleaning solution and sanitizing solution according to the corresponding sections on the previous page.
2. Using the cleaning solution and a clean soft cloth, wash down the sides of the ice bin and the surface of the aluminum casting.
3. Using clean, potable water, thoroughly rinse away the cleaning solution from the sides and surface of the casting.
4. Using plastic sanitary gloves, soak a white cotton gauze cleaning rag in the sanitizing solution and wipe all surfaces in the ice compartment.

⚠ CAUTION

A fresh water rinse cannot follow sanitation of equipment. Purge only with the end use product. This is an NSF requirement.

5. Sanitizing of the ice compartment is complete. Refill with ice.

PLUMBING DIAGRAMS

2200/2300 Standard, 5 Valve & 6 Valve, [3-1-2] & [2-1-2]

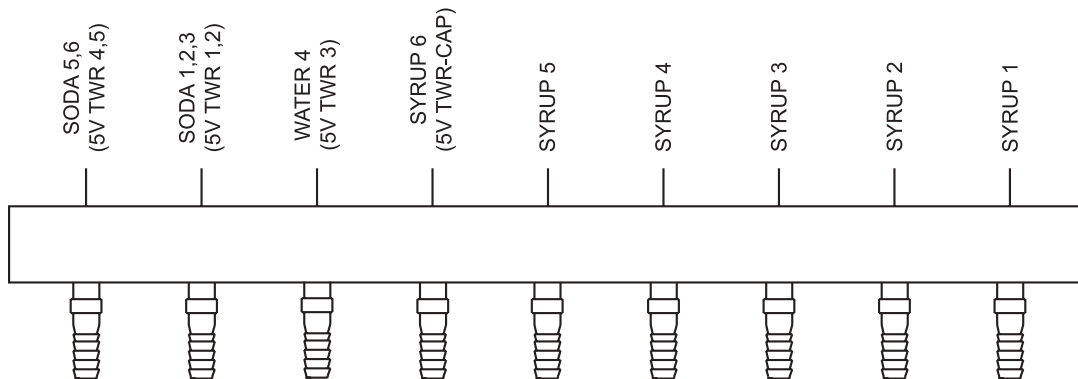

2200/2300 w/ TS, 5 Valve, [3-1-1]

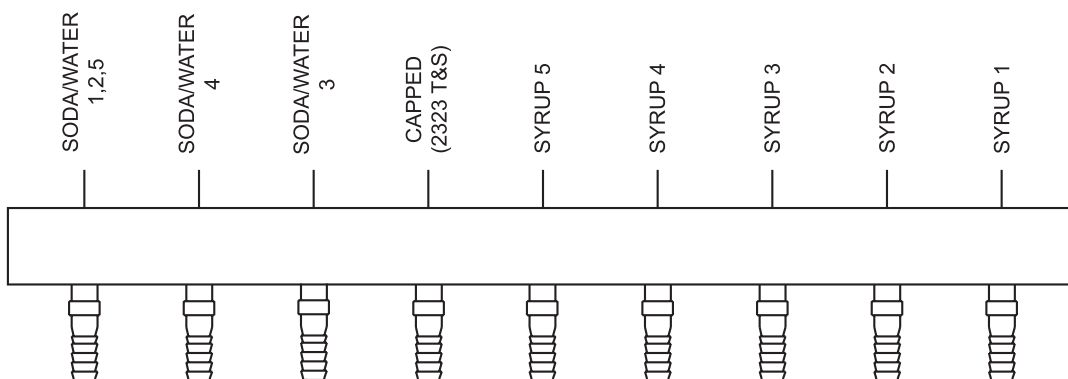

2200/2300, 6 Valve, (3-2-1)

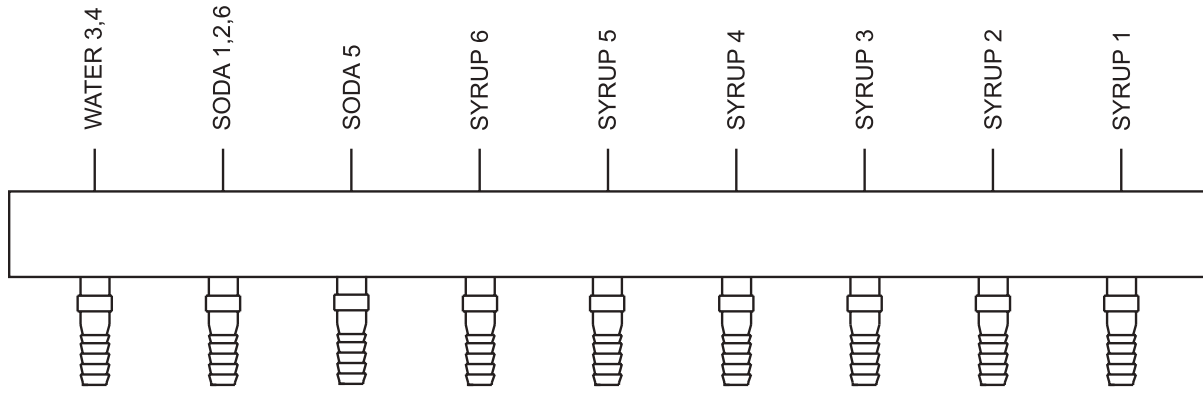

2300 PI, 6 Valve, (3-2-1)

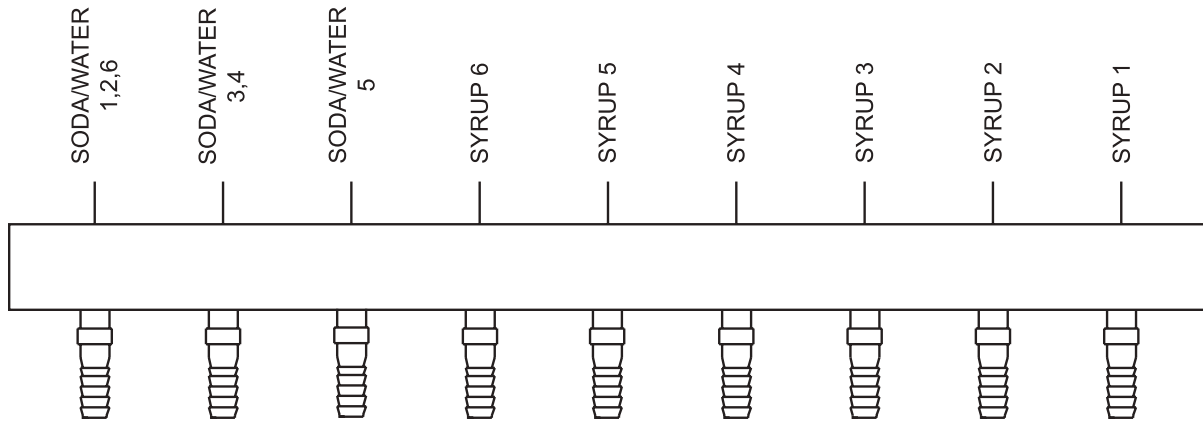

2300, 8 Valve

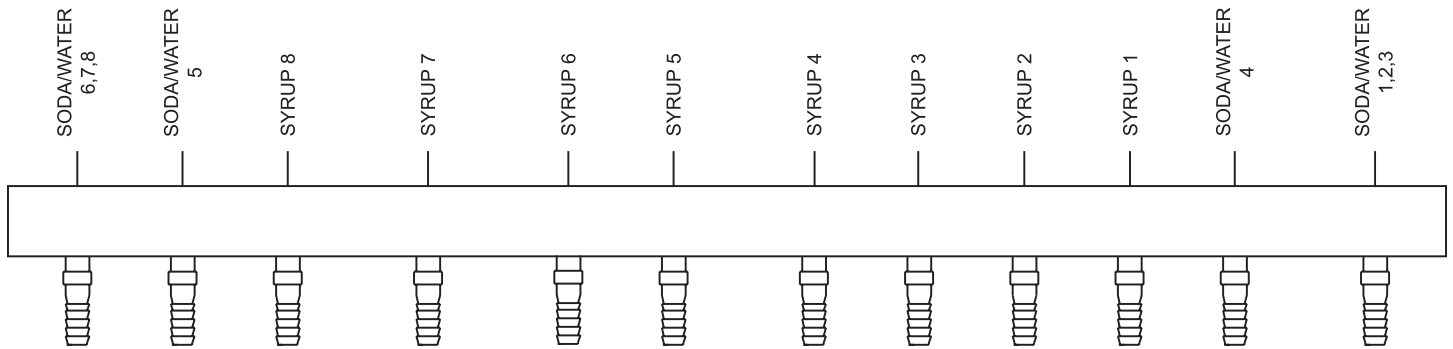

2300, 10 Valve

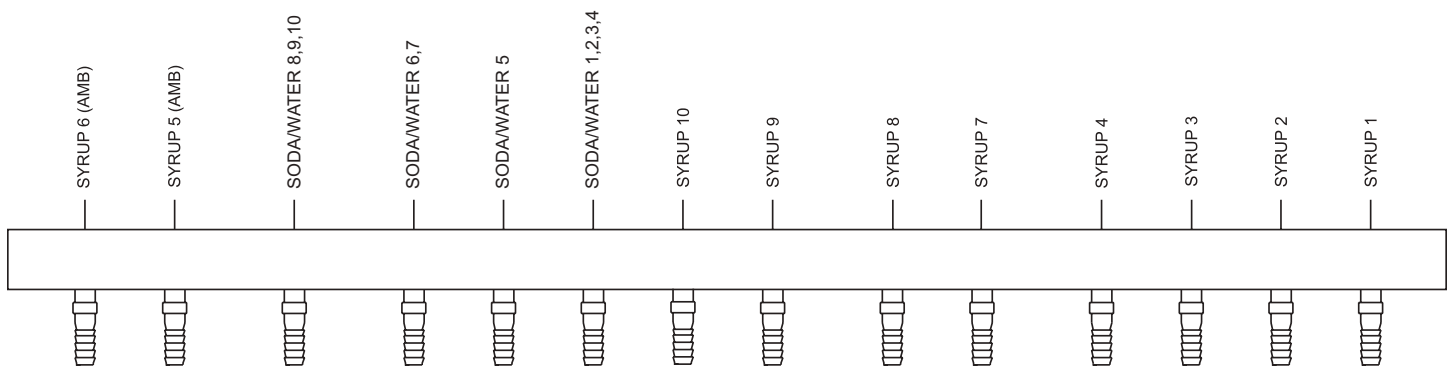

WIRING DIAGRAMS

Ice Cooled Universal Wiring Diagram with Bin Lid Switch

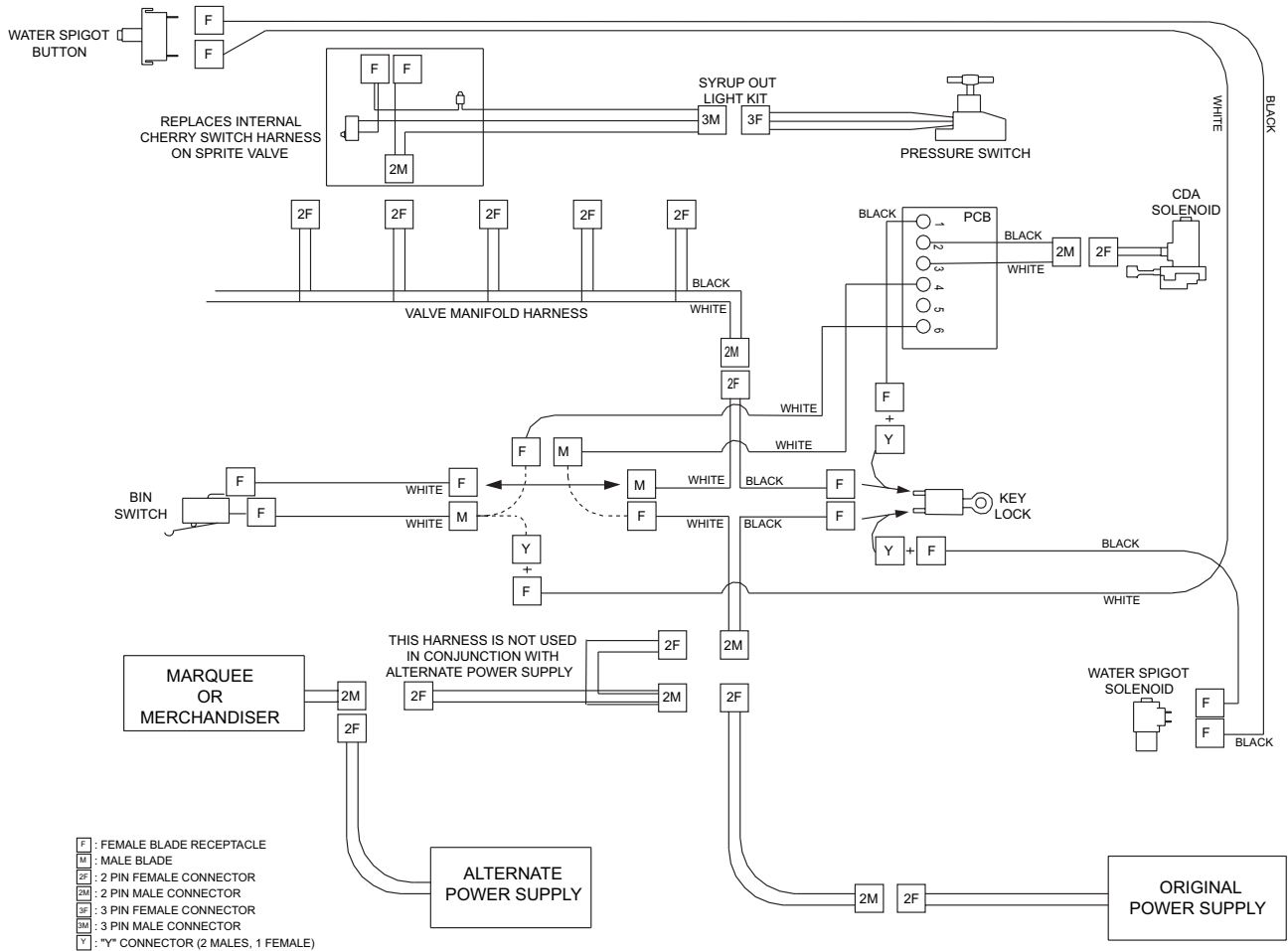

Ice Cooled Universal Wiring Diagram without Bin Lid Switch

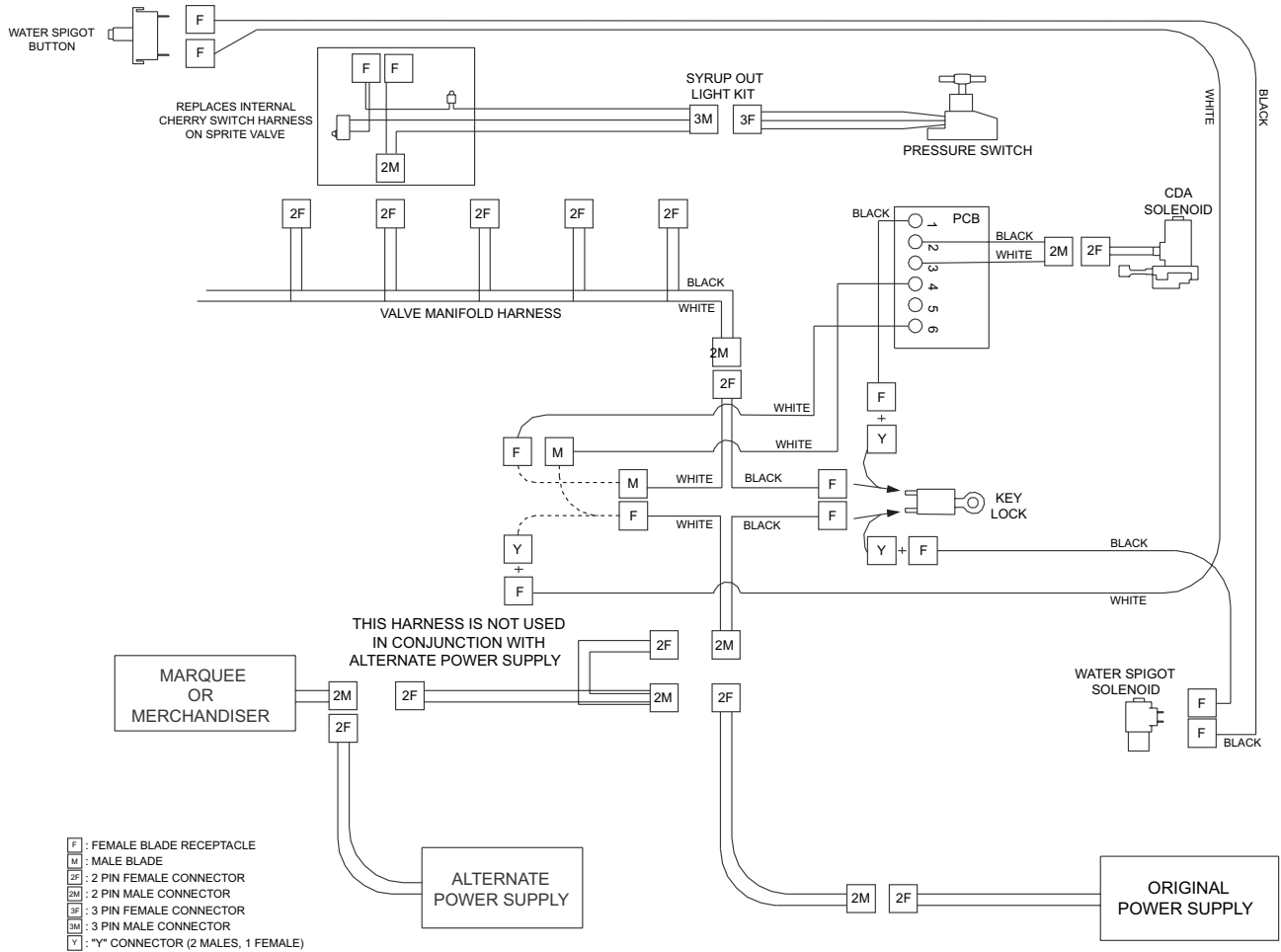

Dispenser Disposal



To prevent possible harm to the environment from improper disposal, recycle the unit by locating an authorized recycler or contact the retailer where the product was purchased. Comply with local regulations regarding disposal of the refrigerant and insulation.

