

LANCER®

FLAVOR SELECT 22 (FS) ICE BEVERAGE DISPENSER

Operation Manual

PN: 28-0580/04



Lancer Corp.
6655 Lancer Blvd.
San Antonio, Texas 78219

800-729-1500
Technical Support/Warranty: 800-729-1550
custserv@lancercorp.com
lancercorp.com



FS22



Manual PN: 28-0580/04

MARCH 2013

FOR QUALIFIED INSTALLER ONLY

ABOUT THIS MANUAL

This booklet is an integral and essential part of the product and should be handed over to the operator after the installation and preserved for any further consultation that may be necessary. Please read carefully the guidelines and warnings contained herein as they are intended to provide the user with essential information for the continued safe use and maintenance of the product. In addition, it provides GUIDANCE ONLY to the user on the correct services and site location of the unit.

The installation and relocation, if necessary, of this product must be carried out by qualified personnel with up-to-date safety and hygiene knowledge and practical experience, in accordance with current regulations.

TABLE OF CONTENTS

ABOUT THE FS22 DISPENSERS/SPECIFICATIONS.....	3-4
PRE-INSTALLATION CHECKLIST.....	5
SAFETY/WARNINGS.....	6-8
1. INSTALLATION.....	9
1.1 UNPACKING THE DISPENSER.....	9
1.2 DRAIN SPIDER.....	9
1.3 SELECTING A LOCATION FOR THE DISPENSER.....	10
1.4 INSTALLING AN ICE MAKER.....	10-11
1.5 LEVELING THE DISPENSER.....	11
1.6 CONNECTING TO WATER SUPPLY LINES.....	11-12
1.7 INSTALLATION OVERVIEW.....	11-12
1.8 CONNECTING CO ₂	13
1.9 CONNECTING TO ELECTRICAL POWER.....	14
1.10 INSTALLING THE FS22 DISPENSER.....	14-15
2. CLEANING AND SANITIZING.....	15
2.1 GENERAL INFORMATION.....	15
2.2 CLEANING AND SANITIZING SOLUTIONS.....	15-16
2.3 DAILY CLEANING.....	16-17
2.4 ICE BIN CLEANING - PERFORM AT STARTUP AND MONTHLY.....	17
2.5 CLEANING/SANITIZING BEVERAGE COMPONENTS - BAG-IN-BOX SYSTEMS.....	18
2.6 ICE CHUTE CLEANING.....	18
3. HOW TO OPERATE AND ADJUST THE DISPENSER.....	18
3.1 NORMAL OPERATION.....	18
3.2 PROGRAMMING AND SETUP SOFTWARE.....	19-20
3.3 PURGING THE CARBONATION SYSTEM.....	20
3.4 PURGING THE WATER AND SYRUP SYSTEMS.....	21
3.5 ADJUSTING WATER FLOW AND WATER TO SYRUP RATIO (BRX).....	21
3.6 CARBONATOR PUMP MODIFICATIONS.....	21
4. TROUBLESHOOTING.....	22-26
5. DISPENSER DISPOSAL.....	26
6. ILLUSTRATIONS, PARTS LISTINGS, AND WIRING DIAGRAMS.....	27
6.1 ICE CHUTE ASSEMBLY.....	27
6.2 FINAL ASSEMBLY.....	28-29
6.3 PELLET ICE ASSEMBLY AND PARTS LISTING.....	30
6.4 LANCER FLOW CONTROL VALVE (LFCV).....	31
6.5 WIRING DIAGRAM.....	32
6.6 PLUMBING DIAGRAM WITH VALVE WIRING.....	33
6.7 WIRING DIAGRAM/PLUMBING DIAGRAM - FS22 INTERNATIONAL.....	34
6.7 FS22 COUNTER CUTOUT.....	35

ABOUT THE FS22

The FS22 is designed using the highest quality materials and state-of-the-art technology providing our customers with consistent quality and a unique drink experience.

FS22 SPECIFICATIONS

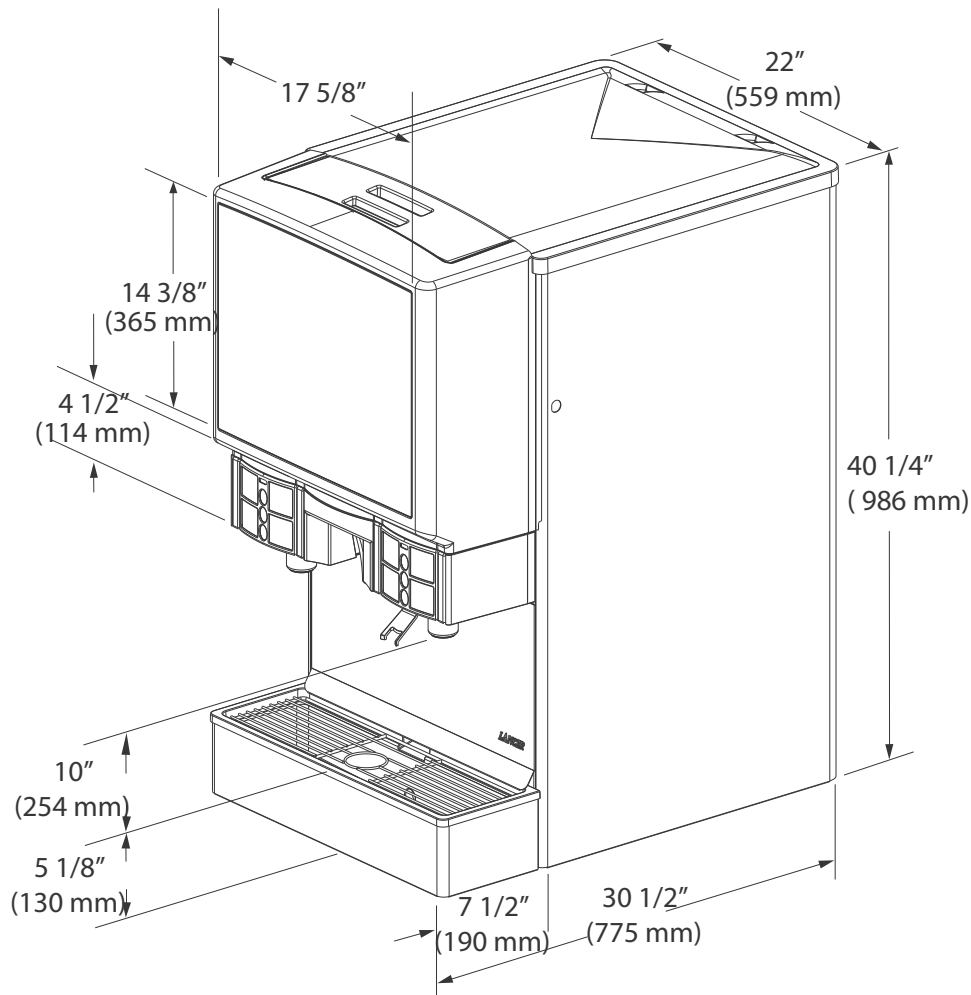

<p>DIMENSIONS Width: 22 in (559 mm) Depth: 30.5 in (775 mm) Height: 40.25 in (1022 mm)</p> <p>SPACE REQUIRED Left Side: 1 in (25 mm) Right side: 1 in (25 mm) Back: 1 in (25 mm) Top: 6 in (152 mm) Optional legs: 4 in (102 mm)</p> <p>ELECTRICAL 220/230 VAC, 50/60Hz, 3.5AMPs 115 VAC, 60 Hz, 7 amps</p>	<p>WEIGHT Without ice: 280 lbs (127 kg) With ice: 480 lbs (218 kg) Shipping: 310 lbs (141 kg)</p> <p>ICE Capacity: 200 lbs (91 kg) Dispensable: 170 lbs (77 kg)</p> <p>FITTINGS Water for carbonator inlet: 3/8" barb Plain water inlet: 3/8" barb Brand syrup inlets: 3/8" barb Injection flavor inlets: 1/4" barb CO2 inlet: 3/8" barb</p>	<p>PLAIN WATER SUPPLY Min flowing pressure: 75 PSIG (0.517 MPA)</p> <p>CARBONATOR WATER SUPPLY Min flowing pressure: 25 PSIG (0.172 MPA) Max static pressure: 50 PSIG (0.345 MPA)</p> <p>CARBON DIOXIDE (CO2) Min pressure: 70 PSIG (0.483 MPA) Max pressure: 80 PSIG (0.552 MPA)</p>
--	--	---

This unit emits a sound pressure level below 70 dB

FS22 INTERNATIONAL SPECIFICATIONS

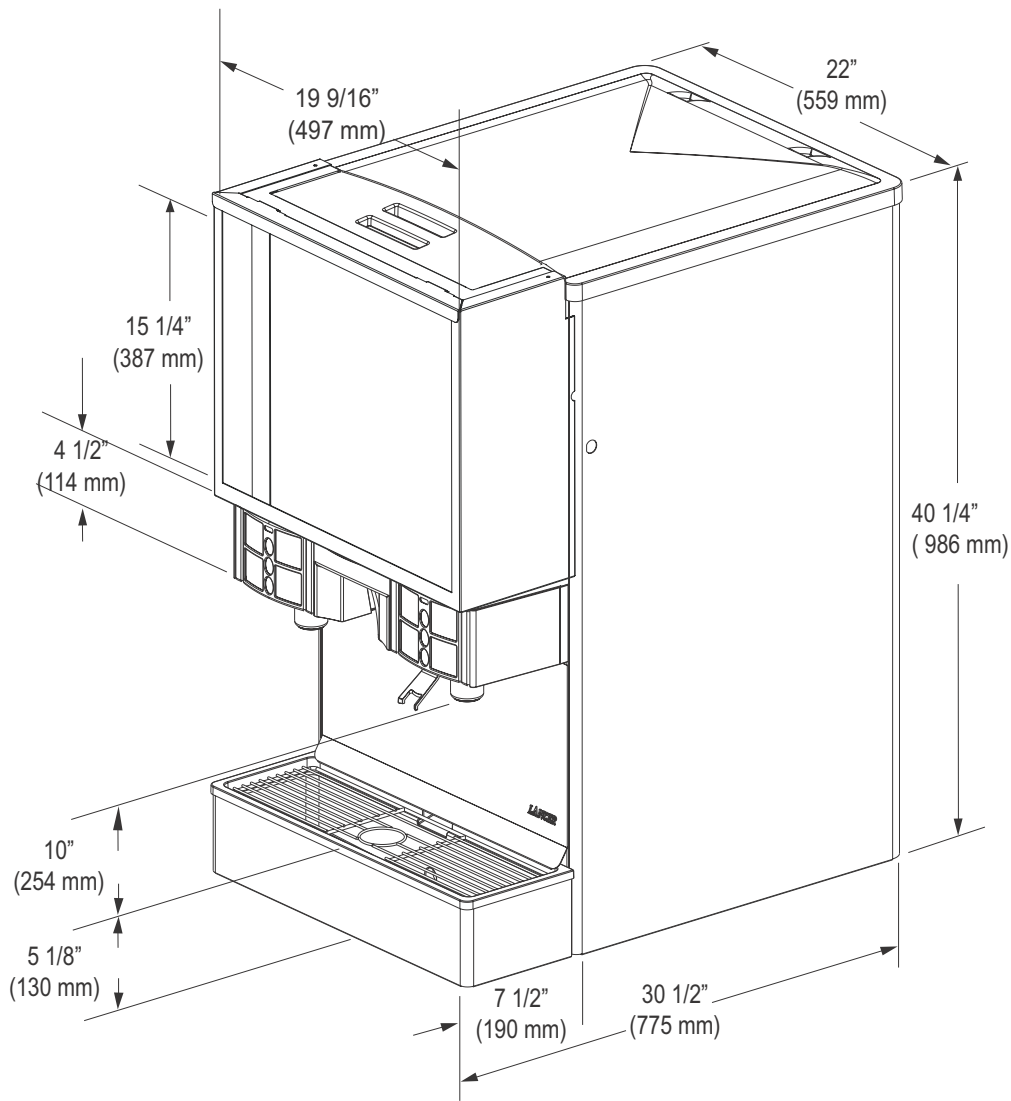

<p>DIMENSIONS Width: 22 in (559 mm) Depth: 30.5 in (775 mm) Height: 40.25 in (1022 mm)</p> <p>SPACE REQUIRED Left Side: 1 in (25 mm) Right side: 1 in (25 mm) Back: 1 in (25 mm) Top: 6 in (152 mm) Optional legs: 4 in (102 mm)</p> <p>ELECTRICAL 220/230 VAC, 50/60Hz, 3.5AMPs 115 VAC, 60 Hz, 7 amps</p>	<p>WEIGHT Without ice: 280 lbs (127 kg) With ice: 480 lbs (218 kg) Shipping: 310 lbs (141 kg)</p> <p>ICE Capacity: 200 lbs (91 kg) Dispensable: 170 lbs (77 kg)</p> <p>FITTINGS Water for carbonator inlet: 3/8" barb Plain water inlet: 3/8" barb Brand syrup inlets: 3/8" barb Injection flavor inlets: 1/4" barb CO2 inlet: 3/8" barb</p>	<p>PLAIN WATER SUPPLY Min flowing pressure: 75 PSIG (0.517 MPA)</p> <p>CARBONATOR WATER SUPPLY Min flowing pressure: 25 PSIG (0.172 MPA) Max static pressure: 50 PSIG (0.345 MPA)</p> <p>CARBON DIOXIDE (CO2) Min pressure: 70 PSIG (0.483 MPA) Max pressure: 80 PSIG (0.552 MPA)</p>
--	--	---

This unit emits a sound pressure level below 70 dB

PRE-INSTALLATION CHECKLIST

BEFORE GETTING STARTED

Each unit is tested under operating conditions and is thoroughly inspected before shipment. At the time of shipment, the carrier accepts responsibility for the unit. Upon receiving the unit, carefully inspect the carton for visible damage. If damage exists, have the carrier note the damage on the freight bill and file a claim with carrier. Responsibility for damage to the dispenser lies with the carrier.

TOOLS REQUIRED	
<input type="checkbox"/> Oetiker Pliers	<input type="checkbox"/> Slotted Screwdriver
<input type="checkbox"/> Tubing Cutters	<input type="checkbox"/> Phillips Screwdriver
<input type="checkbox"/> Wrench	

POST MIX ACCESSORIES	
<input type="checkbox"/> CO2 Regulator Set	<input type="checkbox"/> CO2 Supply
<input type="checkbox"/> Beverage Tubing	<input type="checkbox"/> Oetiker Clamps/Fittings
<input type="checkbox"/> Water Booster	<input type="checkbox"/> Water Regulator

BIB SYSTEM	
<input type="checkbox"/> BIB Rack	<input type="checkbox"/> BIB Regulator Set
<input type="checkbox"/> BIB Syrup Boxes	
<input type="checkbox"/> BIB Connectors - ensure you have the correct connectors for syrup lineup.	

CONSIDER LOCATION OF THE FOLLOWING PRIOR TO INSTALL	
<input type="checkbox"/> Water supply lines	<input type="checkbox"/> Drain
<input type="checkbox"/> Is the countertop level?	<input type="checkbox"/> Heating and air conditioning ducts
<input type="checkbox"/> Grounded electrical outlet.	
<input type="checkbox"/> Enough space to install the dispenser. Include space for a top-mounted ice machine, if necessary.	
<input type="checkbox"/> Does the top-mounted ice machine have a minimum clearance on all sides?	
<input type="checkbox"/> Located away from direct sunlight or overhead lighting.	
<input type="checkbox"/> Can the countertop support the weight of the dispenser? Be sure to include the weight of an ice machine (if necessary) plus the weight of the ice.	
<input type="checkbox"/> This unit is not suitable for use in an area where a water jet could be used.	



WARNING/ADVERTENCIA/AVERTISSEMENT



⚠ The dispenser is for indoor use only. This appliance is intended for use in commercial applications such as restaurants, stores or similar. This unit is not a toy. It should not be used by children or infirm persons without supervision. This appliance is not intended for use by persons (including children) with reduced physical, sensory or mental capabilities, or lack of experience and knowledge, unless they have been given supervision or instruction concerning use of the appliance by a person responsible for their safety. Cleaning and user maintenance shall not be performed by children without supervision. This unit is not designed to dispense dairy products. The minimum/maximum ambient operating temperature for the dispenser is 40°F to 90°F (4°C to 32°C). Do not operate unit below minimum ambient operation conditions. Should freezing occur, cease operation of the unit and contact authorized service technician. Service, cleaning and sanitizing should be accomplished only by trained personnel. Applicable safety precautions must be observed. Instruction warnings on the product being used must be followed.

⚠ El dispensador sólo debe usarse en interiores. Esta unidad está diseñada para su uso en aplicaciones comerciales tales como restaurantes, tienda o similares. Esta unidad no es un juguete. No la deben usar niños ni personas discapacitadas sin supervisión. Esta unidad no está destinada al uso por parte de personas (incluso niños) con capacidad física, sensorial o mental reducida, o sin experiencia y conocimientos suficientes, a menos que una persona responsable de su seguridad les haya dado supervisión o capacitación en el uso de la unidad. Limpieza y mantenimiento de usuario no deberá ser realizada por los niños sin supervisión. Esta unidad no ha sido diseñada para suministrar productos lácteos. La temperatura ambiente operativa mínima / máxima para el dispensador es de 40°F a 90°F (4°C a 32°C). No opere la unidad por debajo de las condiciones mínimas de funcionamiento ambiente. En caso de ocurrir congelación, cesar la operación de la unidad y póngase en contacto con el servicio técnico autorizado. Servicio de limpieza y desinfección debe llevarse a cabo solamente por personal especializado. Precauciones de seguridad aplicables deben ser observadas. Advertencias de instrucciones en el producto que se use debe ser seguido.

⚠ Le distributeur est destiné à un usage à l'intérieur seulement. Cet appareil est conçu pour une utilisation dans des applications commerciales telles que les restaurants, les dépanneurs ou similaires. Cet appareil n'est pas un jouet. Il ne devrait pas être utilisé par des enfants ou des personnes infirmes sans surveillance. Cet appareil n'est pas destiné à un usage par des personnes (y compris les enfants) ayant des capacités physiques, sensorielles ou mentales réduites, ou manquant d'expérience et de connaissances, à moins qu'elles obtiennent de la surveillance ou des instructions au sujet de l'utilisation de l'appareil de la part d'une personne chargée de leur sécurité. Nettoyage et entretien de l'utilisateur ne doivent pas être effectués par des enfants sans surveillance. Cet appareil n'est pas conçu pour distribuer des produits laitiers. La température de service ambiante minimum/maximum pour le distributeur est de 40°F à 90°F (4°C à 32°C). Ne pas faire fonctionner l'appareil ci-dessous les conditions minimales de fonctionnement ambiantes. Faut-gel se produisent, cesser l'exploitation de l'appareil et contactez technicien agréé. Service de nettoyage et de désinfection doivent être effectués uniquement par du personnel qualifié. Les mesures de sécurité applicables doivent être respectées. Avertissements Instruction sur le produit utilisé doit être suivie.



CO₂/CARBON DIOXIDE /EL ANHÍDRIDO CARBÓNICO/ DIOXYDE DE CARBONE



⚠ Carbon Dioxide (CO₂) is a colorless, noncombustible gas with a light pungent odor. High percentages of CO₂ may displace oxygen in the blood. Prolonged exposure to CO₂ can be harmful. Personnel exposed to high concentrations of CO₂ gas will experience tremors which are followed by a loss of consciousness and suffocation. If a CO₂ gas leak is suspected, immediately ventilate the contaminated area before attempting to repair the leak. Strict attention must be observed in the prevention of CO₂ gas leaks in the entire CO₂ and soft drink system.

⚠ El anhídrido carbónico (CO₂) es un gas incoloro, no combustible, con un olor pungente ligero. Altos porcentajes de CO₂ en la sangre pueden desplazar el oxígeno en la sangre. La exposición prolongada al CO₂ puede ser nociva. El personal expuesto a concentraciones altas de CO₂ sufre temblores seguidos de la pérdida de la consciencia y sofocación. Si se sospecha que existe una pérdida de CO₂, ventile el área contaminada antes de tratar de reparar la pérdida. Hay que prestar suma atención para evitar pérdidas de CO₂ en todo el sistema de CO₂ y de bebidas gaseosas.

⚠ Le dioxyde de carbone (CO₂) est plus lourd que l'air et déplace l'oxygène. Le CO₂ est un gaz incolore et incombustible, ayant une odeur un peu âcre. Des concentrations fortes de CO₂ peuvent déplacer l'oxygène dans le sang. Une exposition prolongée au CO₂ peut être nocive. Le personnel exposé à de fortes concentrations de CO₂ gazeux éprouvera des tremblements, suivis rapidement d'une perte de conscience et de suffocation. On doit faire très attention de prévenir les fuites de CO₂ gazeux dans le système entier de CO₂ et de boisson gazeuse. Si on suspecte qu'il y a une fuite de CO₂ gazeux, aérez le secteur contaminé immédiatement avant d'essayer de réparer la fuite.



ELECTRICAL WARNING/ADVERTENCIA ELÉCTRICA/ AVERTISSEMENT ÉLECTRIQUE



⚠ Check the dispenser serial number plate for correct electrical requirements of unit. Do not plug into a wall electrical outlet unless the current shown on the serial number plate agrees with local current available. Follow all local electrical codes when making connections. If supply cord is damaged, it must be replaced by the manufacturer or an authorized service agent to avoid hazard or injury. Each dispenser must have a separate electrical circuit. Do not use extension cords with this unit. Do not 'gang' together with other electrical devices on the same outlet. The keyswitch does not disable the line voltage to the transformer primary. Always disconnect electrical power to the unit to prevent personal injury before attempting any internal maintenance. The resettable breaker switch should not be used as a substitute for unplugging the dispenser from the powersource to service the unit. Only qualified personnel should service internal components of electrical control housing. Make sure that all water lines are tight and units are dry before making any electrical connections!

⚠ Verifique la placa con el número de serie del dispensador, donde encontrará los requisitos eléctricos correctos de la unidad. No enchufe la unidad en un tomacorriente de pared a menos que la corriente indicada en la placa con el número de serie concuerde con la corriente local disponible. Si el cable de alimentación está dañado, debe ser reemplazado por el fabricante o un agente de servicio autorizado para evitar riesgos o lesiones. Al hacer las conexiones, respete todos los códigos eléctricos locales. Cada dispensador debe tener un circuito eléctrico independiente. No use extensiones con esta unidad. No la conecte junto con otros dispositivos eléctricos al mismo tomacorriente. El interruptor de llave no corta el voltaje de línea al transformador primario desconecte siempre la alimentación eléctrica a la unidad para evitar lesiones personales antes de tratar de realizar tareas de mantenimiento. El disyuntor de sobrecarga reseteable no se debe usar como sustituto para desenchufar el dispensador de la fuente de alimentación para realizar tareas de servicio de la unidad. El servicio de los componentes internos de la caja de control eléctrico debe confiarse exclusivamente a personal calificado. Asegúrese de que todas las líneas de agua estén ajustadas y las unidades estén secas antes de hacer conexiones eléctricas.

⚠ Examinez la plaque de numéro de série du distributeur pour connaître les bonnes exigences en matière d'électricité pour l'appareil. Ne le branchez pas à une prise électrique murale à moins que le courant indiqué sur la plaque de numéro de série corresponde au courant local disponible. Si le cordon d'alimentation est endommagé, il doit être remplacé par le fabricant ou un technicien agréé pour éviter tout danger ou de blessure. Respectez tous les codes électriques locaux lorsque vous faites des connexions. Chaque distributrice doit avoir un circuit électrique séparé. N'utilisez pas de cordons prolongateurs avec cet appareil. Ne pas le brancher avec d'autres appareils électriques sur la même prise. L'interrupteur à clé ne coupe pas la tension secteur au transformateur primaire. Débranchez toujours le courant électrique à l'appareil, afin de prévenir des blessures, avant de faire un entretien interne quelconque. Le disjoncteur réarmable ne devrait pas être utilisé au lieu de débrancher le distributeur de la source d'alimentation en électricité pour faire de l'entretien/une réparation de l'appareil. Seul le personnel qualifié devrait faire l'entretien/la réparation des composants internes dans le logement des commandes électriques. Assurez-vous que toutes les conduites d'eau sont étanches et que les appareils sont secs avant de faire des connexions électriques!



AUTOMATIC AGITATION/AGITACIÓN AUTOMÁTICA/



⚠ Units equipped with automatic agitation and will activate unexpectedly. Do not place hands or foreign objects in the ice storage unit compartment. Unplug the dispenser during servicing, cleaning and sanitizing.

⚠ Las unidades equipadas con agitación se activan repentinamente. No ponga las manos ni objetos extraños en el compartimiento de almacenamiento de hielo. Desenchufe el dispensador durante tareas de servicio, limpieza y esterilización.

⚠ Les appareils sont munis d'agitation automatique et s'activeront de manière imprévue. Ne placez pas vos mains ou des corps étrangers dans le compartiment de stockage de l'appareil. Débranchez le distributeur pendant son entretien, son nettoyage et sa désinfection.



WATER NOTICE/ADVERTENCIA DE SUMINISTRO DE AGUA/AVERTISSEMENT D'ALIMENTATION DE L'EAU



⚠ Provide an adequate potable water supply. Water pipe connections and fixtures directly connected to a potable water supply must be sized, installed, and maintained according to federal, state, and local laws. The water supply line must be at least a 3/8 inches (9.525 mm) pipe with a minimum of 75 PSI (0.517 MPA) line pressure, but not exceeding a maximum of 125 PSI (0.860 MPA). Water pressure exceeding 125 PSI (0.860 MPA) must be reduced to 125 PSI (0.860 MPA) with the provided pressure regulator. Use a filter in the water line to avoid equipment damage and beverage off-taste. Check the water filter periodically, as required by local conditions. The water supply must be protected by means of an air gap, a backflow prevention device (located upstream of the CO2 injection system) or another approved method to comply with NSF standards. A leaking inlet water check valve will allow carbonated water to flow back through the pump when it is shut off and contaminate the water supply. Ensure the backflow prevention device complies with ASSE and local standards. It is the responsibility of the installer to ensure compliance.

⚠ Proporcione un suministro adecuado de agua potable. La línea de suministro de agua debe ser de una tubería de por lo menos 3/8 pulgadas (9.525 mm) con una presión de línea mínima de 75 PSI (0.517 MPAr) , pero sin superar el máximo de 125 PSI (0.860 MPA). La presión de agua que supere los 125 PSI (0.860 MPAr) se debe reducir a 125 PSI (0.860 MPA) con un regulador de presión. Use un filtro en la línea de agua para evitar daños al equipo y cierto sabor raro en las bebidas. Verifique periódicamente el filtro de agua de acuerdo con las condiciones imperantes. El suministro de agua debe estar protegido por una separación de aire, un dispositivo de prevención del contraflujo (situado antes del sistema de inyección de CO2) u otro método aprobado para cumplir las normas NSF. Si la válvula de retención de entrada de agua tuviera pérdidas, permitiría el contraflujo del agua carbonatada a través de la bomba cuando se la detiene y contaminaría el suministro de agua. Asegúrese de que el dispositivo de prevención del contraflujo cumpla con las normas locales y de ASSE. Es responsabilidad del instalador cumplir con estos requisitos.

⚠ Fournissez une alimentation en eau potable adéquate. Les connexions et les dispositifs de conduite d'eau connectés directement à une alimentation en eau potable doivent être calibrés, installés et maintenus selon les lois fédérales, provinciales et locales. La conduite d'alimentation en eau doit être un tuyau d'au moins 3/8 pouces (9.525 millimètres) avec une pression de ligne minimum de 75 LPC (0.517 MPA), mais ne doit pas dépasser un maximum de 125 (0.860 MPA). Une pression d'eau de plus de 125 LPC (0.860 MPA) doit être réduite à 125 LPC (0.860 MPA) avec le régulateur de pression fourni. Utilisez un filtre dans la conduite d'eau pour éviter des dommages à l'équipement et un goût des boissons qui n'est pas juste. Vérifiez le filtre à eau périodiquement, selon les exigences des conditions locales. L'alimentation en eau doit être protégée au moyen d'un intervalle d'air, un disconnecteur hydraulique (situé en amont du système d'injection de CO2) ou une autre méthode approuvée pour se conformer aux normes de la NSF. Un clapet antiretour pour l'eau entrante qui fuie permettra à l'eau gazeuse de repasser par la pompe quand elle est fermée et de contaminer l'alimentation en eau. Assurez-vous que le disjoncteur hydraulique soit conforme aux normes de l'ASSE et locales. L'installateur est responsable d'assurer la conformité.

ⓘ ICE INFORMATION ⓘ

Dispensers using cubed ice may also use pellet ice if properly configured. Contact Lancer Customer Service or your Sales Representative for more information. Lancer dispensers will not dispense shaved or flaked ice. Do use bagged ice. Bagged ice will damage components.

Dispensadores con cubitos de hielo también puede usar el hielo pellet si está bien configurado. Comuníquese con el Servicio al Cliente Lancer o su representante de ventas para distribuidores información. Lancer más no dispensará afeitado o en copos de hielo. Hacer uso de hielo en bolsas. Hielo en bolsas dañará los componentes.

Distributeurs à l'aide de glaçons peut aussi utiliser de la glace à granulés s'il est correctement configuré. Contactez le service clientèle Lancer ou votre représentant des ventes pour les distributeurs information. Lancer plus ne distribue pas rasé ou en flocons de glace. Faire utiliser de la glace en sac. Glace en sac endommager les composants.

1. INSTALLATION

THINGS TO CONSIDER:

Connecting lines can be run through the back of the dispenser or extend down through a counter cutout. Seal the dispenser directly on the countertop.

1.1 UNPACKING THE DISPENSER

- A. Set shipping carton upright on the floor. Cut band and remove. Remove any staples that secure the shipping board and lid to the carton. Open top of carton and remove interior packing.
- B. Lift carton up and off of the dispenser. Remove wood shipping base from the bottom of the dispenser. (Support dispenser while removing shipping base to prevent damage to the dispenser.)
- C. Remove installation parts kits from the ice compartment.
- D. Inspect unit and parts for concealed damage(s). If damage exists, notify delivering carrier and file a claim against the carrier.
- E. To remove the merchandiser: remove the two (2) screws on the Faucet Plate that secure the merchandiser. The two (2) screws are located (from the left), above the second and third nozzle and the sixth nozzle.

1.2 DRAIN SPIDER

The drain spider (Fig 1) is located directly in the center of the bin under the ice shroud. The coldplate has a cavity designed to hold the drain spider. During shipment or installation, the drain spider may become dislodged from its original position. Prior to installing the dispenser, ensure the drain spider is in the correct position. This will prevent drain clog issues. Inspect the lower bin area and reach under the shroud to ensure the drain spider is secure in the coldplate cutout.

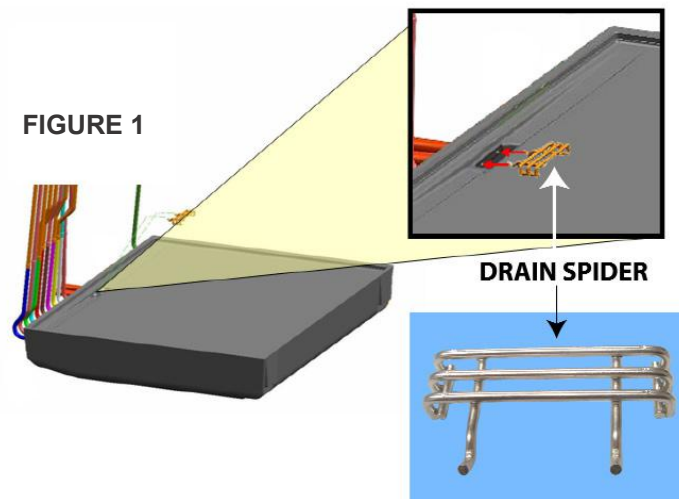

If the drain spider is not in place, proceed with the following steps:

- A. Remove agitator clip and pin from agitator bar.
- B. Remove agitator bar from paddle wheel.
- C. Remove paddle wheel.
- D. Remove ice shroud by lifting back then out of bin.
- E. Locate drain spider and reinstall in the coldplate cavity where drain line exits (see figure above).
- F. Reinstall all components. Ensure agitator clip is locked.



1.3 SELECTING A LOCATION

Connecting lines can be run through the back of the dispenser or extend down through a counter cutout. Seal the dispenser directly on the countertop. Counter Cutouts are located in the Section 5. Illustrations, Parts Listings and Wiring Diagrams.

- A. Select a level, well ventilated, accessible location away from direct sunlight (avoid) or overhead lighting (convenient to water, soda, and syrup lines and open type drain), a properly grounded electric supply and ensure sufficient clearance for air circulation.
- B. Sufficient clearance must be provided, if an ice maker is not installed, to allow filling the ice compartment from a five gallon bucket (a minimum of 16 inches (106.4 mm) is recommended), refer to Fig 3. Lancer does NOT recommend the use of shaved or flake ice in the dispenser.
- B. The selected location should be able to support the weight of the dispenser, ice and possibly an ice maker being installed after counter cut out is made. Total weight (with ice maker) could exceed 800 pounds (363.6kg).
- C. Unit may be installed directly on the countertop or on legs. If installed directly on the counter, the unit must be sealed to the countertop with an FDA approved sealant. If an ice maker is to be mounted on top of dispenser, do not install dispenser on legs.
- D. The dispenser is only to be installed in locations where it can be overseen by trained personnel.

NOTE: The ice level should not exceed the height of the metal bin wall when filled manually (Fig 3).

FIGURE 3. Unit Displayed (no icemaker)

NOTE: Fill ice with merchandiser intact.

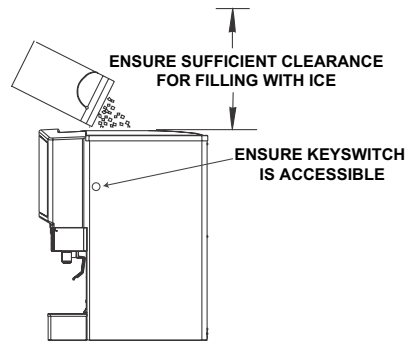

1.4 INSTALLING AN ICEMAKER

WARNING WHEN INSTALLING AN ICEMAKER ON THE DISPENSER, USE A BIN THERMOSTAT TO CONTROL THE ICE LEVEL (SEE BELOW). THIS WILL PREVENT DAMAGE TO THE DISPENSING MECHANISM. THE BRACKET FOR MOUNTING A THERMOSTAT IS LOCATED IN THE ICE BIN. DURING THE AUTOMATIC AGITATION CYCLE AND WHILE DISPENSING ICE, ENSURE THERE IS ADEQUATE SPACE BETWEEN THE TOP OF THE ICE LEVEL AND THE BOTTOM OF THE ICEMAKER SO THE ICE CAN MOVE WITHOUT OBSTRUCTION. CONTACT YOUR ICEMAKER MANUFACTURER FOR INFORMATION ON A SUITABLE BIN THERMOSTAT.

ADVERTENCIA CUANDO INSTALA UNA MÁQUINA DE CUBITOS EN EL DISPENSADOR, USE UN TERMOSTATO DE RECIPIENTE PARA CONTROLAR EL NIVEL DE HIELO (VER MÁS ABAJO). DE ESTA FORMA SE EVITAN LOS DAÑOS AL MECANISMO DISPENSADOR. EL SOPORTE PARA MONTAR EL TERMOSTATO ESTÁ EN EL RECIPIENTE DEL HIELO. DURANTE EL CICLO AUTOMÁTICO DE AGITACIÓN Y CUANDO SE DISPENSA HIELO, ASEGÚRESE DE QUE HAYA ESPACIO ADECUADO ENTRE LA PARTE SUPERIOR DEL NIVEL DE HIELO Y LA PARTE INFERIOR DE LA MÁQUINA DE CUBITOS, DE MODO QUE EL HIELO SE MUEVA SIN OBSTRUCCIONES. COMUNÍQUESE CON EL FABRICANTE DE SU MÁQUINA DE CUBITOS PARA OBTENER INFORMACIÓN SOBRE UN TERMOSTATO DE RECIPIENTE ADECUADO.

AVERTISSEMENT LORS DE L'INSTALLATION D'UN APPAREIL À CUBES DE GLACE SUR LE DISTRIBUTEUR, UTILISEZ UN THERMOSTAT DE BAC POUR CONTRÔLER LE NIVEAU DE GLACE (VOIR CI-DESSOUS). CECI EMPÊCHERA LES DOMMAGES AU MÉCANISME DE DISTRIBUTION. LE SUPPORT POUR FIXER UN THERMOSTAT SE TROUVE DANS LE BAC DE GLACE. PENDANT LE CYCLE D'AGITATION AUTOMATIQUE ET LORS DE LA DISTRIBUTION DE LA GLACE, ASSUREZ-VOUS QU'IL Y A ASSEZ D'ESPACE ENTRE LE DESSUS DU NIVEAU DE GLACE ET LE FOND DE L'APPAREIL À CUBES DE GLACE, POUR QUE L'APPAREIL À CUBES DE GLACE PUISSE BOUGER SANS OBSTRUCTION. CONTACTEZ VOTRE FABRICANT D'APPAREILS À CUBES DE GLACE POUR OBTENIR DES INFORMATIONS SUR UN THERMOSTAT DE BAC APPROPRIÉ.

- A. Install the icemaker per manufacturer specifications. Points of consideration include drainage, ventilation, and drop zones.
- B. An adapter plate is required when installing an icemaker. Contact your Sales Representative or Lancer Customer Service for more information.
- C. A bin thermostat is required in order to control the level of ice in the dispenser (Refer to WARNING above. Contact your icemaker manufacturer to obtain the correct bin thermostat. The bin thermostat should be a minimum of 2" (50.8 mm) below the top edge of the dispenser. The preferred location of the bin thermostat is on the right side wall above the auger.

1.4 INSTALLING AN ICEMAKER (CONTINUED)



ATTENTION FAILURE TO USE AN ICE BIN THERMOSTAT WILL NOT ONLY VOID YOUR IBD'S WARRANTY BUT WILL RESULT IN THE INABILITY TO CONTROL THE LEVEL OF ICE IN THE ICE BIN WHICH CAN CAUSE DAMAGE TO YOUR DISPENSER.

ATENCIÓN SI NO SE UTILIZA UN TERMOSTATO DEL DEPÓSITO DE HIELO NO SÓLO SE ANULARÁ LA GARANTÍA, PERO RESULTARÁ EN LA INCAPACIDAD DE CONTROLAR EL NIVEL DE HIELO EN EL DEPÓSITO DE HIELO CUAL PUEDE CAUSAR DAÑOS A SU DISPENSADOR.

ATTENTION NE PAS UTILISER UN THERMOSTAT DE BAC À GLAÇONS NE SERA PAS SEULEMENT ANNULER VOTRE GARANTIE, MAIS SE TRADUIRA PAR L'INCAPACITÉ DE CONTRÔLER LE NIVEAU DE LA GLACE DANS LE BAC À GLAÇONS QUI PEUT CAUSER DES DOMMAGES À VOTRE DISTRIBUTEUR.

- D. Ensure the icemaker is installed properly to allow for removal of the merchandiser.
- E. Ensure manual fill is accessible.
- F. Clean and maintain icemaker per manufacturer's instructions.

FIGURE 4

Attach Bin Stat Bracket As Shown

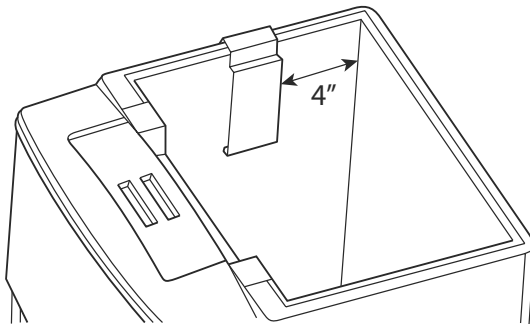

Recommended Bin Stat Attachment

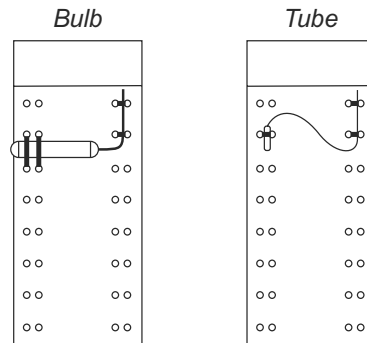

1.5 LEVELING THE DISPENSER

In order to facilitate proper dispenser drainage and carbonation, ensure that the dispenser is level, front to back and side to side. Place a level on the top of the rear edge of the dispenser. The bubble must settle between the level lines (Fig 5). Repeat this procedure for the remaining three sides. Level unit if necessary. For optimum performance place the unit at a 0 degree tilt. The maximum tilt is 5 degrees.

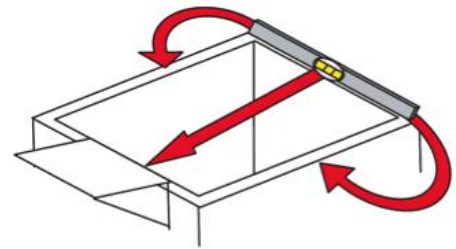

FIGURE 5

1.6 CONNECTING TO WATER SUPPLY LINES

NOTE: In addition to the following, adhere to **WATER SUPPLY WARNINGS AND CAUTIONS**, Page 7.

WATER NOTICE

For the plain water supply line, the inlet water flowing pressure should be at least 75 PSI (0.517 MPA). If the water pressure is lower than 75 PSI (0.517 MPA) flowing, use a water booster system.

If the water flowing pressure is lower than 75 PSI (0.517 MPA) at the plain water inlet and a water booster is NOT installed, water products will not hold a proper flow rate or water/syrup ratio. Flow conditions at the nozzle can also be affected, causing poor nozzle coning and mixing.

For the soda water supply line, do not exceed 50 PSI (0.345 MPA) for the inlet water static pressure going into the carbonator pump. If the static water pressure exceeds 50 PSI (0.345 MPA), install a water regulator before the carbonator water inlet.

The Lancer Water Booster/Tank (PN MC-163172) is offered as a kit. The water booster must be installed as close as possible to the plain water circuit inlet.

Install the water regulator (Lancer PN 18-0306) included with unit as close as possible to the water carbonator pump inlet. The recommended water pressure value feeding the carbonator is a minimum of 25 PSI (0.172 MPA). If the normal water pressure does not exceed 50 PSI (0.345 MPA), but fluctuates over this value (for example, when water usage on other equipment connected to the same water supply causes pressure spikes), use a water regulator.

1.6 CONNECTING TO WATER SUPPLY LINES (CONTINUED)

- A. Installer should provide new beverage tubing that meets the IEC Standard 61770. Do not reuse beverage tubing. Lancer beverage tubing kits are available for purchase. Contact your Sales Representative or Lancer Customer Service for more information. Use a filter in the water line. Failure to do so can result in equipment damage and beverage off-taste. Check the water filter periodically, as required by local conditions.



CAUTION FAILURE TO DISCONNECT THE MOTOR POWER SUPPLY WILL DAMAGE THE CARBONATOR MOTOR, THE PUMP AND VOID THE WARRANTY.

PRECAUCIÓN SI NO DESCONECTA LA ALIMENTACIÓN ELÉCTRICA DEL MOTOR PODRÍAN DAÑARSE LA BOMBA Y EL MOTOR DEL CARBONATADO Y ANULAR LA GARANTÍA.

ATTENTION LE FAIT DE NE PAS MAINTENIR LE DÉGAGEMENT SPÉCIFIÉ FERA SURCHAUFFER LE COMPRESSEUR ET AURA COMME CONSÉQUENCE UNE DÉFAILLANCE DU COMPRESSEUR.

- B. Protect the water supply by means of an air gap, a backflow prevention device, or another approved method that complies with NSF standards. A leaking inlet water check valve will allow carbonated water to flow back through the pump when it is shut off and contaminate the water supply. Ensure the backflow prevention device complies with ASSE and local standards. It is the responsibility of the installer to ensure compliance.
- C. Provide an adequate potable water supply. Water pipe connections and fixtures directly connected to a potable water supply must be sized, installed, and maintained according to federal, state, and local laws.



CAUTION DO NOT CONNECT TO A HOT WATER OR SOFT WATER SOURCE. THIS CAUSES EXCESSIVE FOAMING.

PRECAUCIÓN NO LO CONECTE A UNA FUENTE DE AGUA CALIENTE O AGUA BLANDA. ESTO PROVOCA UN EXCESO DE ESPUMA.

ATTENTION NE PAS RACCORDER À UN CHAUFFE-EAU OU D'UNE SOURCE D'EAU DOUCE. CELA PROVOQUE UN MOUSSAGE EXCESSIF. AURA COMME CONSÉQUENCE UNE DÉFAILLANCE DU COMPRESSEUR.

1.7 INSTALLATION OVERVIEW

A. FIGURE 6: FS22-1

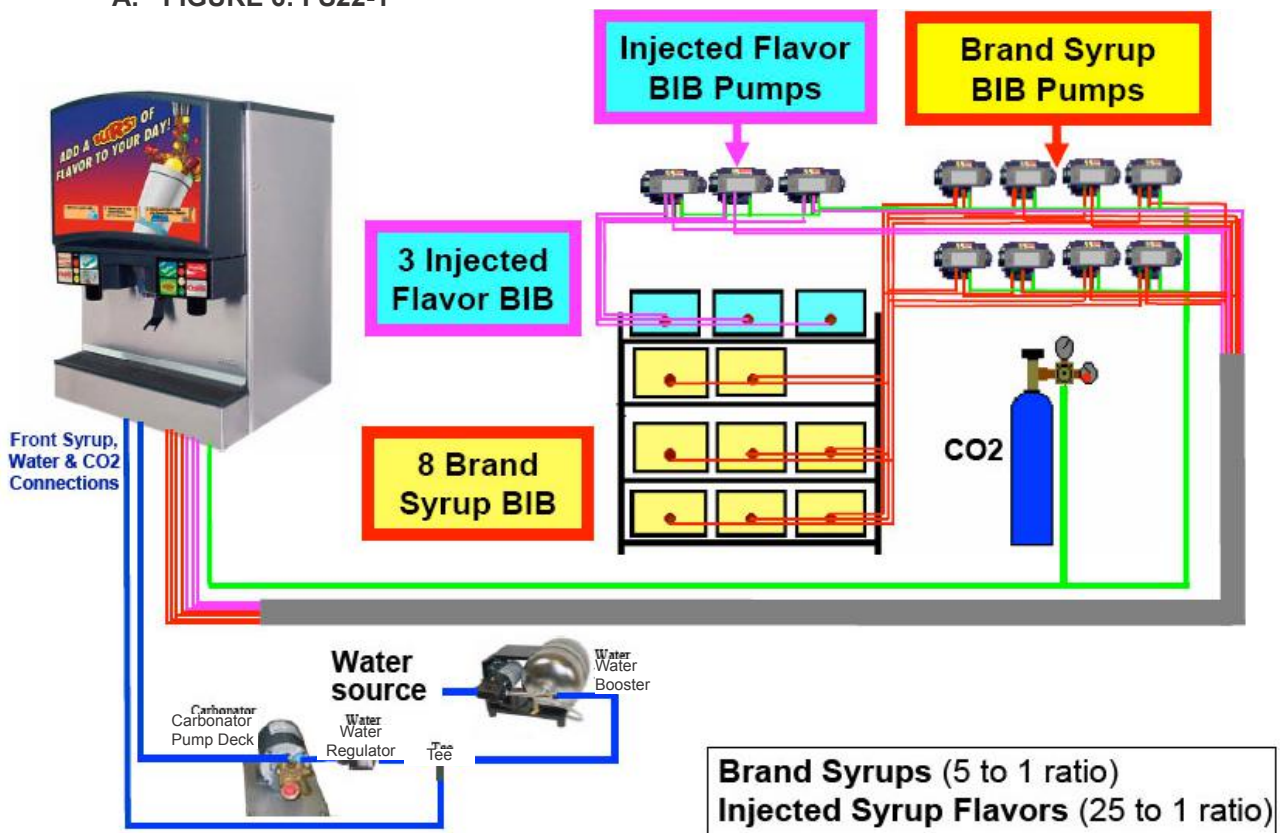

1.7 INSTALLATION OVERVIEW (CONTINUED)

B. FIGURE 7: FS22-2

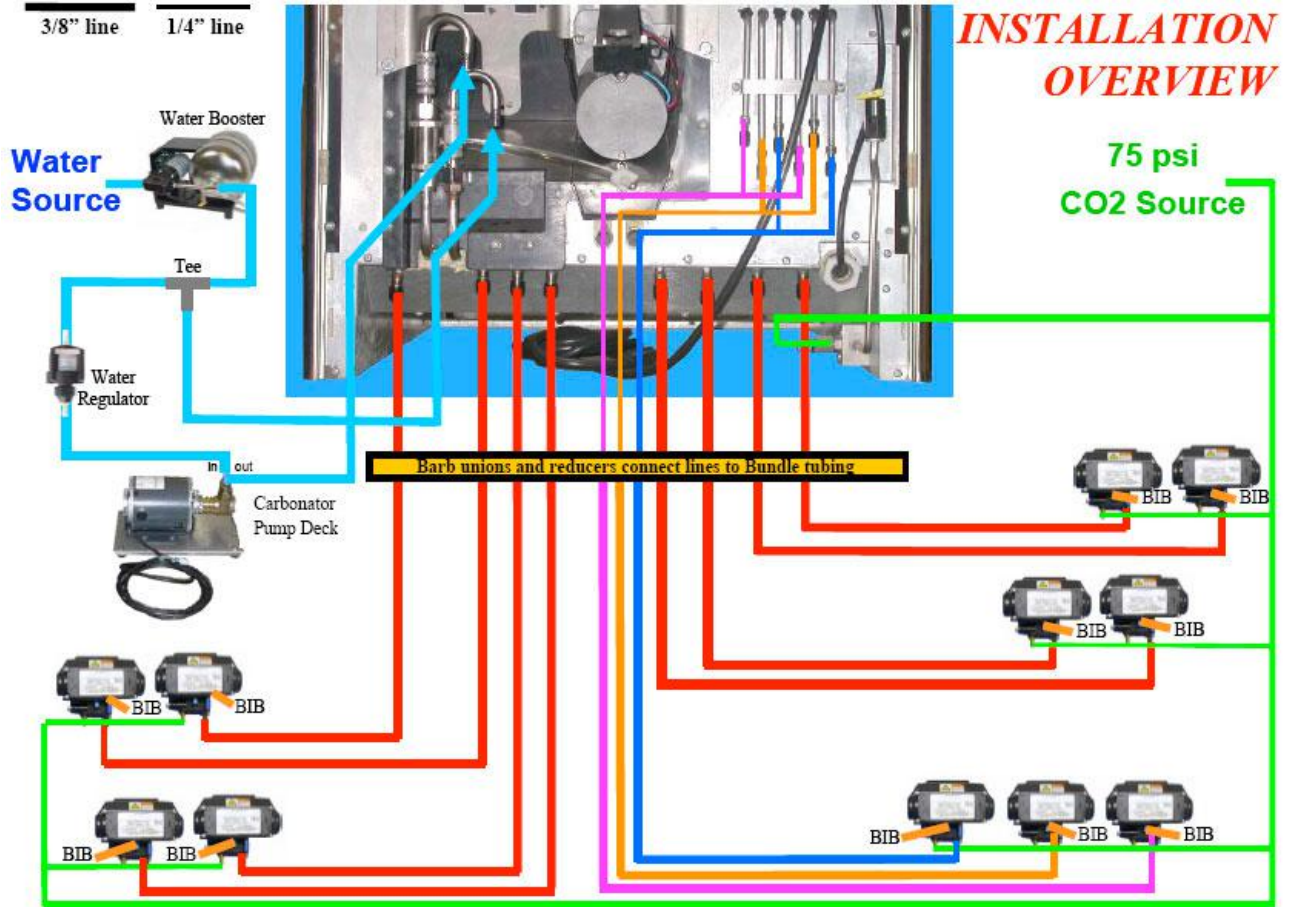

1.8 CONNECTING CO2

- A. Provide a regulated CO2 supply to the dispenser through a 3/8 inch supply line. The maximum pressure is 80 PSI (0.552 MPA).



CAUTION EXCESSIVE CO2 PRESSURE CAN DAMAGE COMPONENTS.

PRECAUCIÓN PRESIÓN DE CO2 EN EXCESO PUEDE DAÑAR LOS COMPONENTES.

ATTENTION UNE PRESSION EXCESSIVE PEUT ENDOMMAGER LES COMPOSANTS DE CO2.

1.9 CONNECTING TO ELECTRICAL POWER

NOTE: In addition to the following, adhere to the ELECTRICAL Warnings and Cautions, page 6.



GROUNDING WARNING THE DISPENSER MUST BE PROPERLY ELECTRICALLY GROUNDED TO AVOID SERIOUS INJURY OR FATAL ELECTRICAL SHOCK. THE POWER CORD HAS A THREE-PRONG GROUNDED PLUG. IF A THREE-HOLE GROUNDED ELECTRICAL OUTLET IS NOT AVAILABLE, USE AN APPROVED METHOD TO GROUND THE UNIT. FOLLOW ALL LOCAL ELECTRICAL CODES WHEN MAKING CONNECTIONS. EACH DISPENSER MUST HAVE A SEPARATE ELECTRICAL CIRCUIT. DO NOT USE EXTENSION CORDS. DO NOT CONNECT MULTIPLE ELECTRICAL DEVICES ON THE SAME OUTLET.

ADVERTENCIA, PUESTA A TIERRA ES NECESARIO PONER A TIERRA ELÉCTRICAMENTE EL DISPENSADOR PARA EVITAR LESIONES GRAVES E INCLUSO ELECTROCHOQUES FATALES. EL CABLE DE ALIMENTACIÓN TIENE UN ENCHUFE PUESTO A TIERRA DE 3 CLAVIJAS. SI NO SE DISPONE DE UN TOMA ELÉCTRICO CONECTADO A TIERRA DE TRES AGUJEROS, USE UN MÉTODO APROBADO PARA PONER A TIERRA LA UNIDAD. AL HACER LAS CONEXIONES, RESPETE TODOS LOS CÓDIGOS ELÉCTRICOS LOCALES. CADA DISPENSADOR DEBE TENER UN CIRCUITO ELÉCTRICO INDEPENDIENTE. NO USE CABLES DE EXTENSIÓN. NO CONECTE VARIOS DISPOSITIVOS ELÉCTRICOS AL MISMO TOMACORRIENTE.

EXIGENCES DE MISE À LA TERRE LA DISTRIBUTRICE DOIT ÊTRE MISE À LA TERRE ÉLECTRIQUEMENT CORRECTEMENT POUR ÉVITER DES BLESSURES GRAVES OU UNE DÉCHARGE ÉLECTRIQUE MORTELLE. LE CORDON D'ALIMENTATION A UNE FICHE À TROIS BRANCHES MISE À LA TERRE. SI AUCUNE PRISE DE COURANT ÉLECTRIQUE À TROIS TROUS N'EST DISPONIBLE, UTILISEZ UNE MÉTHODE APPROUVÉE POUR METTRE L'UNITÉ À LA TERRE. RESPECTEZ TOUS LES CODES ÉLECTRIQUES LOCAUX LORSQUE VOUS FAITES DES CONNEXIONS. CHAQUE DISTRIBUTRICE DOIT AVOIR UN CIRCUIT ÉLECTRIQUE SÉPARÉ. N'UTILISEZ PAS DE CORDONS PROLONGATEURS. NE BRANCHEZ PAS PLUSIEURS APPAREILS ÉLECTRIQUES À LA MÊME PRISE DE COURANT.

- A. Check the dispenser serial number plate for correct electrical requirements of unit. Do not plug into wall electrical outlet unless the current/voltage shown on the serial number plate agrees with local current/voltage available.

1.10 INSTALLING THE FS22 DISPENSER

- A. Remove the cup rest, drip tray, splash plate, and top cover from the unit.
- B. Remove the cover plate at the back of the unit (if not a through-the-counter installation).
- C. Connect the plain water supply line and the water supply for the carbonator to the 3/8 inch barb fittings at the front of the unit.

NOTE: Install the water regulator (Lancer PN 18-0306) as close as possible to the water carbonator pump inlet. Refer to Figure 6. The recommended water pressure value feeding the carbonator is a minimum of 25 PSI (0.172 MPA). If the no mal water pressure does not exceed 50 PSI (0.345 MPA), but fluctuates over this value (for example, when water usage on other equipment connected to the same water supply causes pressure spikes), use a water regulator.

- D. Place the CO2 cylinder with the CO2 regulator in a serviceable location and route the CO2 supply line (75 PSI)(0.517 MPA) to the 3/8 inch barb fitting at the front of the unit.
- E. Connect the syrup supply lines to the 3/8 inch barb inlet fittings at the front of the unit. Connect other end to BIB pumps.
- F. Connect the flavor injection lines to the barb fittings at the front of the unit.
- G. Install the drip tray and extend the hose to an open drain.
- H. Insulate drain lines with a closed cell insulation. Ensure that the insulation covers the entire length of the drain hose, including fittings. To prevent condensation from forming, install the drain so that water does not collect in sags or other low points. **NOTE:** Pouring hot water into the drain may cause the drain tube to collapse. Allow only lukewarm or cold water to enter drain tube. Pouring coffee, tea, and similar substances into the drain can cause the drain tube to become clogged.
- I. Install the cup rest and splash plate.
- J. Connect the power cord to a grounded electrical outlet.



AGITATION WARNING THE BIN AGITATION SYSTEM WILL OPERATE AUTOMATICALLY. DO NOT PLACE HANDS IN THE BIN OR THE ICE CHUTE.

ADVERTENCIA AGITACIÓN EL SISTEMA FUNCIONARÁ AUTOMÁTICAMENTE BIN AGITACIÓN. NO DA PARA ARRIBA EN LA BANDEJA O LA CASCADA DE HIELO.

AGITATION AVERTISSEMENT LE SYSTÈME FONCTIONNERA AUTOMATIQUEMENT BIN AGITATION. NE PAS METTRE LES MAINS DANS LE BAC OU LA GOULOTTE DE GLACE.

CONTINUED ON NEXT PAGE

1.10 INSTALLING THE FS22 DISPENSER (CONTINUED)

- K. Test motor operation by pushing the ice chute.
- L. Clean and sanitize the dispenser (Section 2).
- M. Fill the dispenser half full with ice. Test ice delivery by pushing the ice chute.
- N. Fill the dispenser with ice.
- O. Install the top cover.
- P. Set the brix ratio for beverage dispensing valves according to the manufacturer's instructions.

FIGURE 8

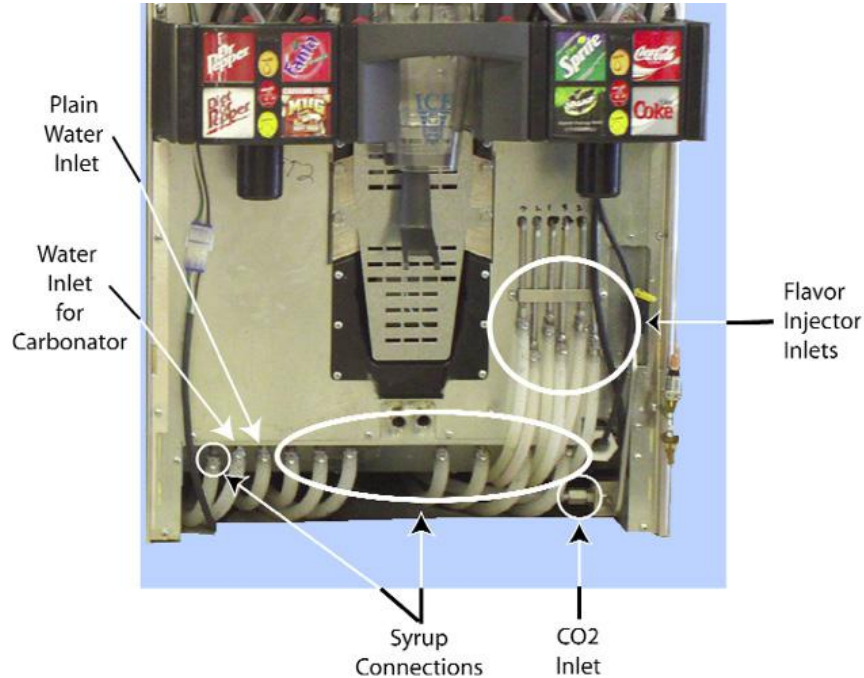

2. CLEANING AND SANITIZING INSTRUCTIONS

2.1 GENERAL INFORMATION

- A. The cleaning and sanitizing procedures provided pertain to the Lancer equipment identified by this manual. If other equipment is being cleaned, follow the guidelines established by the manufacturer for that equipment.
- B. Lancer equipment (new or reconditioned) is shipped from the factory cleaned and sanitized in accordance with NSF guidelines. The equipment must be cleaned and sanitized after installation is complete. The operator of the equipment must provide continuous maintenance as required by this manual and state and local health department guidelines to ensure proper operation and sanitation requirements are maintained.
- C. Cleaning and sanitizing should be accomplished only by trained personnel. Sanitary gloves are to be used during cleaning and sanitizing operations. Applicable safety precautions must be observed. Instruction warnings on the product being used must be followed.
- D. Other Required Supplies: 1) Clean cloth towels, 2) bucket, 3) extra nozzle, 4) sanitary gloves and 5) Small brush (PN 22-0017 included with installation kit).

2.2 CLEANING AND SANITIZING SOLUTIONS

CLEANING SOLUTION: Mix a mild, non-abrasive detergent (e.g. Sodium Laureth Sulfate, dish soap) with clean, potable water at a temperature of 90°F to 110°F (32°C to 43°C). The mixture ratio is one ounce of cleaner to two gallons of water. Prepare a minimum of five gallons of cleaning solution. Do not use abrasive cleaners or solvents because they can cause permanent damage to the unit. Ensure rinsing is thorough, using clean, potable water at a temperature of 90°F to 110°F. Extended lengths of product lines may require additional cleaning solution.

2.2 CLEANING AND SANITIZING SOLUTIONS (CONTINUED)

SANITIZING SOLUTION: Prepare sanitizing solutions in accordance with the manufacturer's written recommendations and safety guidelines. The solution must provide 50 to 100 parts per million (PPM) chlorine (e.g. Sodium Hypochlorite or bleach). A minimum of five gallons of sanitizing solution should be prepared. Any sanitizing solution may be used as long as it is prepared in accordance with the manufacturer's written recommendations and safety guidelines, and provides 50 to 100 parts per million (PPM) chlorine.



WARNING IF A POWDER SANITIZER IS USED, DISSOLVE IT THOROUGHLY WITH HOT WATER PRIOR TO ADDING TO THE SYRUP SYSTEM. ENSURE SANITIZING SOLUTION IS REMOVED FROM THE DISPENSER AS INSTRUCTED. AVOID GETTING SANITIZING SOLUTION ON CIRCUIT BOARDS. DO NOT USE STRONG BLEACHES OR DETERGENTS; THESE CAN DISCOLOR AND CORRODE VARIOUS MATERIALS. DO NOT USE METAL SCRAPERS, SHARP OBJECTS, STEEL WOOL, SCOURING PADS, ABRASIVES, OR SOLVENTS ON THE DISPENSER. DO NOT USE HOT WATER ABOVE 140° F (60° C). THIS CAN DAMAGE THE DISPENSER.

ADVERTENCIA SI SE USA UN HIGIENIZADOR EN POLVO, DISUÉLVALO BIEN EN AGUA ANTES DE AGREGARLO AL SISTEMA DE CONCENTRADO. EL USO DE AGUA CALIENTE CONTRIBUYE A DISOLVER LOS HIGIENIZADORES EN POLVO. ASEGÚRESE DE HABER ELIMINADO LA SOLUCIÓN DE ESTERILIZACIÓN DEL DISPENSADOR DE ACUERDO CON LAS INSTRUCCIONES. LOS RESIDUOS DE LA SOLUCIÓN DE ESTERILIZACIÓN REPRESENTAN UN PELIGRO PARA LA SALUD. EVITE QUE LA SOLUCIÓN DE ESTERILIZACIÓN LLEGUE A LAS PLACAS DE CIRCUITOS. NO USE LAVANDINAS NI DETERGENTES QUE PODRÍAN QUITAR EL COLOR Y CORROER DISTINTOS MATERIALES. NO USE RASPADORES METÁLICOS, OBJETOS FILOSOS, LANA DE ACERO, ESTROPAJOS, ABRASIVOS NI SOLVENTES EN EL DISPENSADOR. NO USE AGUA CALIENTE A MÁS DE 140 °F (60 °C). PODRÍA DAÑAR EL DISPENSADOR.

AVERTISSEMENT AVANT L'INJECTION DANS LE SYSTÈME, IL FAUDRA QUE LA POUDRE SEPTIQUE SOIT DISSOLUE ENTIÈREMENT DANS CHAUDE. L'EAU CHAUDE PERMETTRA UN MEILLEUR PROCÈS DE DISSOLUTION. SUIVANT LES INSTRUCTIONS JOINTES, IL EST IMPÉRATIF QUE LA SOLUTION SEPTIQUE SOIT ENTIÈREMENT ENLEVÉE. EVITEZ DE METTRE LA SOLUTION EN CONTACT AVEC LES CIRCUITS. N'UTILISEZ PAS DE JAVELLISANTS OU DEDÉTERGENTS FORTS; CEUX-CI PEUVENT DÉCOLORER ET CORRODER DIVERS MATÉRIAUX. N'UTILISEZ PAS DE RACLEURS EN MÉTAL, D'OBJETS POINTUS, DE LAINE D'ACIER, DE TAMPONS À RÉCURER, D'ABRASIFS OU DE SOLVANTS SUR LE DISTRIBUTEUR. N'UTILISEZ PAS DE L'EAU CHAUDE DE PLUS DE 140 DEGRÉS F (60 DEGRÉS C). CECI PEUT ENDOMMAGER LE DISTRIBUTEUR.

DO NOT disconnect water lines when cleaning and sanitizing syrup lines, to avoid contamination.

DO NOT use strong bleaches or detergents; these can discolor and corrode various materials.

DO NOT use metal scrapers, sharp objects, steel wool, scouring pads, abrasives, or solvents on the dispenser.

DO NOT use hot water above 140 degrees F (60 degrees C). This can damage the dispenser.

2.3 DAILY CLEANING

- Carefully remove the nozzle housings by turning counterclockwise and pulling down from the nozzle body.
- Wash the nozzle housings in cleaning solution and rinse with clean warm water.
- Wet a clean cloth in cleaning solution.
- While the nozzle housing is removed, wipe down the perimeter and end of the nozzle body.

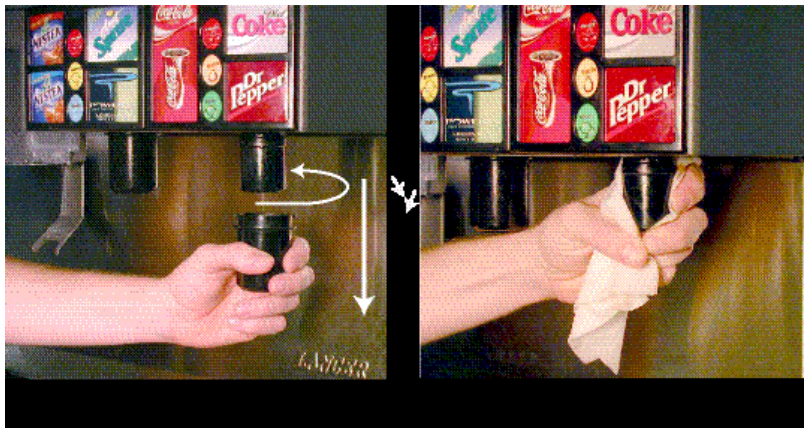

2.3 DAILY CLEANING (CONTINUED)

- E. Fill a cup with clean warm water and rinse nozzle body.
- F. Make certain that the nozzle o-ring is not torn or otherwise damaged. If necessary, replace damaged o-ring with Lancer PN 02-0231.
- G. Wet the inner surface of the nozzle housing with water and reinstall the nozzle housing by sliding it over the nozzle body and turning clockwise to lock in position.

2.4 ICE BIN CLEANING - PERFORM AT STARTUP AND MONTHLY

- A. Disconnect power to the dispenser.
- B. Remove the top cover.
- C. Melt out any remaining ice from the bin.
- D. Remove the splash plate, drip tray and front and rear bin covers.
- E. Remove the agitator pin from the agitator shaft. Slide the agitator shaft rearward out of the motor shaft and pull out of the rear bearing to remove.
- F. Remove the dispensing wheel from the motor shaft by sliding rearward.

G. WHITE WHEEL SHROUD (PELLET ICE)

G. BLACK WHEEL SHROUD (CUBED ICE)

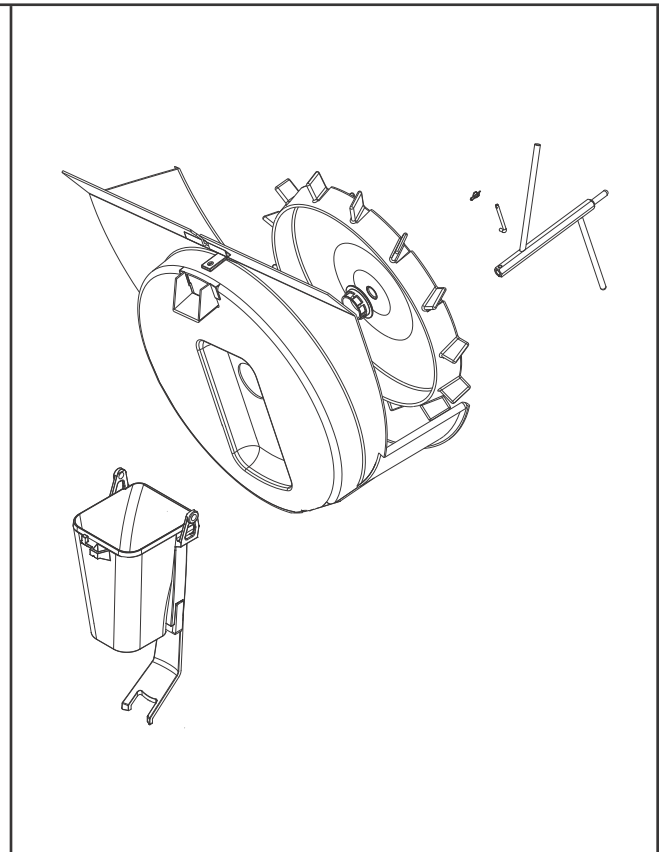
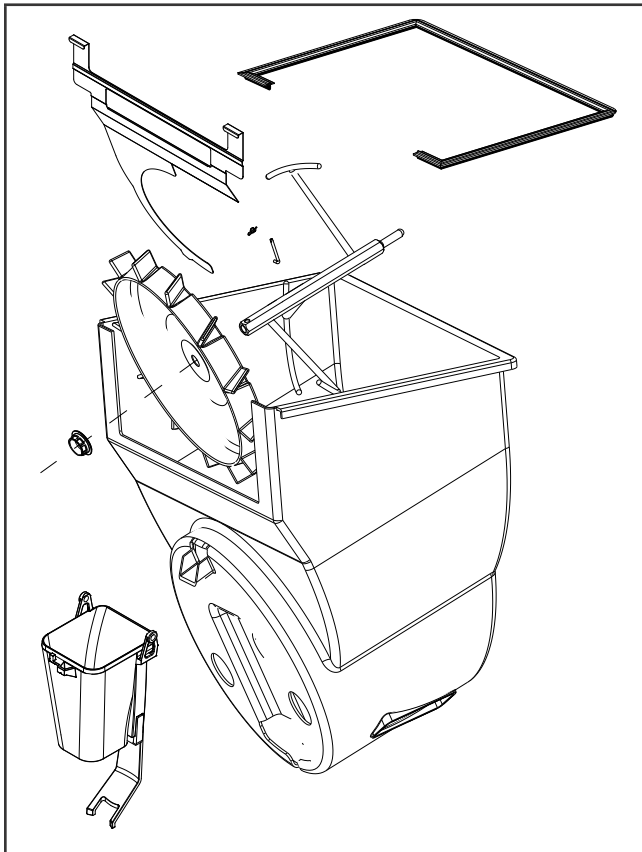

Remove the gasket which secures the shroud by pulling it out.
Push the front section of the shroud back.
Pull the shroud up and out.
Remove the lower ice chute assembly.

Remove the dispensing wheel shroud.
Remove the lower ice chute assembly.

- H. Using the cleaning solution described in the "Cleaning and Sanitizing Solutions" section and a clean cloth or soft brush, clean all removable parts, sides of ice bin, ice chute and surface of aluminum casting.
- I. Using hot water, thoroughly rinse away the cleaning solution.
- J. Wearing sanitary gloves, soak a clean cloth towel in sanitizing solution, described in the "Cleaning and Sanitizing Solutions" section above, and wash all surfaces of removable parts, sides of ice bin, ice chute liner, and surface of aluminum casting.
- K. Wearing sanitary gloves, reassemble all removable parts.
- L. Fill the unit with ice and replace the top cover.
- M. Reconnect the dispenser to the power source. Ensure the agitator clip is locked (Fig 2).

2.5 CLEANING AND SANITIZING BEVERAGE COMPONENTS - BAG-IN-BOX SYSTEMS

NOTE: Extended lengths of product lines may require more time to flush and rinse lines.

- A. Disconnect the syrup quick disconnect coupling from the syrup packages and connect the coupling to a bag valve removed from an empty Bag-in-Box (BIB) package.
- B. Place the syrup inlet line in a clean container filled with clean, potable, room temperature water.
- C. Activate valve until water is dispensed. Flush and rinse line and fittings for a minimum of 60 seconds to remove all traces of residual product.
- D. Following the instructions as described in 2.2 above, mix appropriate amount of cleaning solution in a clean container. Place syrup inlet line in container filled with cleaning solution.
- E. Activate valve and draw cleaning solution through lines for a minimum of 60 seconds. This will ensure line is flushed and filled with cleaning solution. Allow line to stand for at least 30 minutes.
- F. Place syrup inlet line in a clean container filled with clean, potable, water at a temperature of 32° to 43°C.
- G. Activate valve to flush and rinse line and fittings for a minimum of 60 seconds to remove all traces of cleaning solution.
- H. Following the instructions as described in 2.2 above, mix appropriate amount of sanitizing solution in a clean container. Place syrup inlet line in container filled with sanitizing solution. Refer to Section 2.2 WARNING.
- I. Activate valve and draw sanitizing solution through line for a minimum of 60 seconds. This will ensure line is flushed and filled with sanitizing solution. Allow line to stand for at least 30 minutes.
- J. Remove bag valve from quick disconnect coupling and reconnect syrup inlet line to syrup package. Ready unit for operation.
- K. Draw drinks to refill lines and to flush the chlorine sanitizing solution from the dispenser.
- L. Test dispenser in normal manner for proper operation. Taste dispensed product to ensure off-taste is not present. If off-taste is found, additional flushing of syrup system may be required.
- M. Repeat cleaning, rinsing, and sanitizing procedures for each valve and each circuit.

2.6 ICE CHUTE CLEANING

It is recommended to perform this procedure monthly, or more often if desired. Use the cleaning solution described above.

- A. Turn off power to the dispenser.
- B. Remove merchandiser.
- C. Unhook the spring from the upper ice chute by pulling up and out.
- D. Remove the lower chute by carefully spreading apart the arms of the lower chute.
- E. Mix the cleaning solution. Put a portion of the solution into a spray bottle. Soak the lower chute in the remaining solution.
- F. Spray the upper chute with the cleaning solution.
- G. With a soft sponge, clean the inside of the upper and lower chutes.
- H. Rinse the lower chute thoroughly.
- I. Dry the lower chute thoroughly.
- J. Empty the cleaning solution from the spray bottle, then refill with plain water. Rinse the upper chute thoroughly. Dry the upper chute.
- K. Reinstall the lower ice chute onto the upper chute, then reinstall the spring.
- L. Reinstall merchandiser.
- M. Reconnect power to the dispenser.

3. HOW TO OPERATE AND ADJUST THE DISPENSER

3.1 NORMAL OPERATION

- A. Fill cup with desired amount of ice.
- B. Place cup under nozzle below desired brand.
- C. Select up to two desired bonus flavors from those available on the keypad, by pressing against the flavor label once. Selection indicator light will illuminate, acknowledging selection.
- D. Press and hold brand label to fill cup.
- E. Top off cup as desired.

3.2 PROGRAMMING AND SETUP SOFTWARE

NOTE: Lancer reserves the right to make changes and updates as required. If you have any questions regarding the latest versions of programs, please contact your Lancer representative.

The Lancer FS22 has been factory preset to the settings necessary to comply with the brand/flavor version of the unit requested by the customer.

Adjustments or upgrades should only be performed by trained personnel. For any upgrades, an upgrade kit may be purchased. The kit includes all of the hardware required for the upgrade, including bezels and valves.

INITIALIZATION SCREEN (BOOT UP ONLY)

LANCER FS SERIES
VER. 0.xxxx

MAIN MENU

SUB-CATEGORY

FS-22 (NO PWB) MAJOR / MINOR C	BRANDS PER SIDE V:1 L:2 R:2
FS-22 (NO PWB) CONFIG BONUS KEY C	BONUS KEY SETUP V:1 T:F M:F B:F
FS-22 (NO PWB) CARB / WATER SETUP C	CARB / WATER SETUP V1 B1 SODA
FS-22 (NO PWB) CONFIG ICE TYPE C	CONFIG ICE TYPE CUBE PELLET
FS-22 (NO PWB) VW ICE STIR TMS C	ICE STIR ON 2000 ICE STIR OFF 60
FS-22 (NO PWB) SOFTWARE VERSION C	CONTROLLER X.XXX V1 X.XXX
FS-22 (NO PWB) NUMBER OF VALVES C	1 2 Y Y
FS-22 (NO PWB) RESET DEFAULTS C	RELOAD DEFAULTS? NO YES
FS-22 (NO PWB) GLOBAL CONFIG C	SET MAIN CONFIG FS8 (PWB)

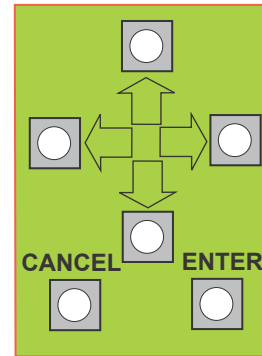

↑ ↓ Scrolls through Main Menu
 Press "Enter" to enter sub-category
 → ← Moves cursor to right or left
 ↑ ↓ Changes value (number/letter)
 Press "Enter" to save changes
 Press "Cancel" to exit menu

NOTE:
C = CUBED ICE
P = PELLET ICE
O = OVERRIDDEN

Valves can be adjusted by scrolling through the menus (see figure above) using the UP and DOWN arrows. By pressing the ENTER button, a submenu is revealed. In the submenu, the individual valves can be adjusted to the desired configuration.

MENUS AND SUBMENUS



1. Bonus Flavors

- Decide if the bonus flavors will be set to add an injected flavor to the brands or dispense carbonated water/plain water.
- Choose the **Valve** number (1-4) by scrolling **UP** and **DOWN** arrows.
- Use the **LEFT** and **RIGHT** arrows to shift to the **Top**, **Middle**, or **Bottom** “bonus” flavors categories.
- Press the **UP** and **DOWN** arrows under **Top**, **Middle**, or **Bottom** to select it as an injected flavor, carbonated **Soda** water, or plain **Water**.
- Press **ENTER** to finalize settings. Panel lights should confirm finalized configurations.

2. Brands

- Decide how the brands will be setup.
- Choose the **Valve** number (1-4) by scrolling **UP** and **DOWN** arrows.
- Use the **LEFT** and **RIGHT** arrows to shift to the **Left** or **Right** categories. **The Left or Right categories are set with the assumption that you are looking at them from the front.**
- Press **UP** and **DOWN** arrows under **Left** (1-2) or **Right** (1-2) to select the brand per side as a single or double. For example, for bezel PN 05-2120, V:1 L:1 R:2

3. Soda/Water

- Decide which switch locations will be carbonated and/or non-carbonated drinks.
- Choose the **Valve** number (2-3) by scrolling the **UP** and **DOWN** arrows.
- Use the **LEFT** and **RIGHT** arrows to shift to the number categories (1-4). The number categories correspond to the brand location (per valve) that is being configured.
- Press the **UP** and **DOWN** arrows under the number to select if that brand will be carbonated **Soda** or non-carbonated plain **Water**. If a single brand per side, only number 1 and/or 3 need to be set.

4. Automatic Agitation

- Each Series 14400 ice beverage dispenser is equipped with automatic agitation for the ice bin. The unit is shipped with timing set at two seconds (2000 milliseconds) ON every sixty minutes for cubed ice. The unit is shipped with timing set at four seconds (4000 milliseconds) ON every 150 minutes for pellet ice.

3.3 PURGING THE CARBONATION SYSTEM

Purge the carbonator tank whenever carbonation issues occur.

- Turn off CO2 supply.
- Turn off power to the unit. Unplug the carbonator harness from the power supply.
- Open the relief valve until water is coming out. Close the relief valve, checking for any remaining air in the tank.
- Allow the carbonator tank to fill with plain water by way of the water booster.
- Once the tank is full, turn the power back on and purge the system by dispensing a carbonated drink. You should only get plain water as the CO2 is still off. Dispense several times.
- Turn on the CO2 supply
- Turn off the power in order to reconnect the pump harness. Turn power back on.
- Dispense soda at valve until the carbonator pump comes on. Release the button, allow the carbonator to fill and stop (usually a few seconds). Repeat this process until the water is carbonated (about five cycles).
- Place dispenser back into service.

NOTE: To check for CO2 leaks, close the valve on the CO2 cylinder and observe if the pressure to the system drops with the cylinder valve closed for five minutes. Open the cylinder valve after check.

3.4 PURGING THE WATER AND SYRUP SYSTEMS

- A. Open a dispensing valve until water and syrup are flowing steadily from the valve. Repeat for each valve.
- B. Check all of the dispenser's syrup and water connections for leaks and repair if necessary.
- C. Replace the dispenser's splash plate and cup rest.

3.5 ADJUSTING WATER FLOW AND WATER TO SYRUP RATIO (BRIX)

The water flow can be adjusted between 3.25 oz/sec (96 ml/sec) and 4.50 oz/sec (133 ml/sec) on all dispensing valves. Ensure ice is on the cold plate for at least one hour before you brix the valves. The drink temperature should be no higher than 40 degrees F (4.4 degrees C) when the brix is set.

- A. Remove merchandiser assembly.
- B. If necessary, rotate switches panel forward and down by releasing the two pin latches on its sides.
- C. Rotate light panel, forward and up by releasing the two pin latches on its sides towards the top.
- D. Remove nozzle by twisting counterclockwise and pulling down.
- E. Install Lancer syrup separator (PN 82-3458) in place of nozzle.
- F. Activate dispensing valve to fill separator syrup tube.
- G. Hold a Lancer brix cup under the syrup separator and dispense water and syrup into cup for four seconds. Divide number of ounces of water in cup by four to determine water flow rate per second.
- H. To obtain the proper flow, remove protective cap, and use a screwdriver to adjust water flow control.
- I. Repeat process for each water valve. There can be up to six gray water valves on this dispenser (up to four carbonated water valves and two plain water valves).
- J. Hold the Lancer brix cup under the syrup separator and activate valve. Check brix.
- K. To obtain the proper brix, use screwdriver to adjust syrup flow control.
- L. Once proper ratio is obtained, repeat to verify.
- M. Repeat process for each valve.
- N. Remove syrup separator.
- O. Install nozzle.
- P. Once all the valves have been brixed, restore switches panel and light panel to their original positions.

3.6 CARBONATOR PUMP MODIFICATIONS

The electric, positive displacement rotary vane pump with 170 PSI bypass should only be serviced by trained personnel. To achieve optimum carbonation, use filtered water with the pump.

- A. Turn off power to the dispenser.
- B. Remove drip tray and splash plate.
- C. Turn off water.
- D. Turn the CO2 off, activate the relief valve.
- E. Once the pressure has been released, untighten the inlet/outlet nuts on the pump.
- F. Unscrew the mounting bracket.
- G. Part should easily slide out for replacement or maintenance.

4. TROUBLESHOOTING

TROUBLE	CAUSE	REMEDY
4.1 No product when switch is activated. (Switch panel does not light up when activated.)	<p>A. Keyswitch is off, or keyswitch harness is disconnected.</p> <p>B. 9-in valve harness is disconnected.</p> <p>C. Defective switch assembly.</p> <p>D. No power to unit</p>	<p>A. Turn keyswitch on and/or reconnect keyswitch harness.</p> <p>B. Turn off power, reconnect 9-pin harness, and restore power.</p> <p>C. Replace switch assembly.</p> <p>D. Check internal breaker and incoming power</p>
4.2 No product when switch is activated. (Switch panel does light up when activated)	<p>A. 25-pin valve harness is disconnected.</p> <p>B. Defective switch assembly</p>	<p>A. Turn off power, reconnect 25-pin harness, and restore power.</p> <p>B. Replace switch assembly.</p>
4.3 Push chute and nothing happens	<p>A. Dispenser not connected to power source.</p> <p>B. Microswitch defective.</p> <p>C. Wiring harness not plugged in.</p> <p>D. PC board defective.</p>	<p>A. Connect dispenser to power source.</p> <p>B. Replace microswitch.</p> <p>C. Plug in wiring harness.</p> <p>D. Replace PC board.</p>
4.4 Push chute. Ice door opens but motor does not run	<p>A. Wiring harness not plugged in.</p> <p>B. PC board defective.</p> <p>C. Motor defective</p>	<p>A. Plug in wiring harness.</p> <p>B. Replace PC board.</p> <p>C. Replace motor</p>
4.5 Push chute. Motor runs but ice door does not open	<p>A. Solenoid not connected to PC board.</p> <p>B. Solenoid defective.</p> <p>C. PC board defective.</p> <p>D. Solenoid bracket screwed too low and not opening completely.</p>	<p>A. Connect solenoid to PC board.</p> <p>B. Replace solenoid.</p> <p>C. Replace PC board.</p> <p>D. Unscrew solenoid bracket, raise solenoid and rescrew bracket.</p>
4.6 Push chute, ice door opens, motor runs, but no ice dispenses, or ice is of poor quality	<p>A. Dispenser is out of ice.</p> <p>B. Agitator pin is missing or damaged.</p> <p>C. Poor ice quality</p>	<p>A. Fill unit with ice.</p> <p>B. Replace agitator pin.</p> <p>C. Install water filtration/purification to icemaker supply water</p>
4.7 Valves do not operate.	<p>A. Keyswitch is off, or keyswitch harness is disconnected.</p> <p>B. Circuit breaker tripped.</p> <p>C. Unit not plugged in.</p>	<p>A. Turn keyswitch and/or make sure keyswitch harness is connected.</p> <p>B. Reset circuit breaker.</p> <p>C. Plug in dispenser</p>

TROUBLE	CAUSE	REMEDY
4.8 Water in ice bin	A. Coldplate drain is obstructed.	A. Remove splash plate to obtain access to drain tubes and clear accordingly.
4.9 Water leakage around nozzle.	A. Damaged or improperly installed o-ring on nozzle	A. If damaged, replace. If improperly installed, adjust
4.10 Miscellaneous leakage.	A. Gap between parts. B. Damaged or improperly installed o-rings	A. Tighten appropriate retaining screws. B. Replace or adjust appropriate o-rings.
4.11 Noisy/cavitating carbonator pump	A. Insufficient incoming water supply pressure.	A. Verify incoming supply water pressure to carbonator pump is a minimum of 25 PSI, 0.172 MPA (max 50 PSI, 0.345 MPA).
4.12 Insufficient soda flow (carbonated drinks).	A. Insufficient CO2 supply pressure. B. Shutoff on mounting block not fully open. C. Foreign debris in soda flow control.	A. Verify incoming CO2 pressure between 70-75 PSI (0.483 - 0.517 MPA) B. Open shutoff fully. C. Remove soda flow control from valve and clean out any foreign material to ensure smooth spool movement.
4.13 Insufficient water flow (plain water).	A. Insufficient incoming supply pressure. B. Shutoff on mounting block not fully open. C. Foreign debris in water flow control. D. Water filtration problem.	A. Verify incoming supply water pressure to plain water inlet is a minimum of 70 PSI, 0.483 MPA (max 125 PSI, 0.862 MPA). B. Open shutoff fully. C. Remove water flow control from valve and clean out any foreign material to ensure smooth spool movement. D. Service water system as required.
4.14 Insufficient syrup flow.	A. Insufficient CO2 pressure to BIB pumps. B. Shutoff on mounting block not fully open. C. Foreign debris in syrup flow control. D. Defective BIB pump.	A. Adjust CO2 pressure to 80 PSI, 0.552 MPA (min 70 PSI, 0.483 MPA) for BIB pumps. B. Open shutoff fully. C. Remove syrup flow control from valve and clean out any foreign material to ensure smooth spool movement. D. Replace pump.

TROUBLE	CAUSE	REMEDY
4.15 Erratic ratio.	<p>A. Incoming water and/or syrup supply not at minimum flowing pressure.</p> <p>B. Foreign debris in water and/or syrup flow control.</p> <p>C. CO2 regulator malfunction.</p>	<p>A. Check pressure and adjust.</p> <p>B. Remove flow control from suspected valve and clean out any foreign material to ensure smooth spool movement.</p> <p>C. Repair or replace CO2 regulator as required.</p>
4.16 Water only dispensed, no syrup. Or syrup only dispensed, no water.	<p>A. Syrup BIB empty.</p> <p>B. Water or syrup shutoff on mounting block not fully open.</p> <p>C. Improper or inadequate water or syrup supply.</p> <p>D. CO2 pressure to syrup pump too low.</p> <p>E. Stalled or inoperative BIB pump.</p> <p>F. Kinked line.</p> <p>G. CO2 regulator malfunction</p>	<p>A. Replace syrup BIB as required.</p> <p>B. Open shutoff fully.</p> <p>C. Remove valve from mounting block, open shutoff slightly and check water and syrup supply. If no supply, check dispenser for other problems. Ensure BIB connection is engaged.</p> <p>D. Check the CO2 pressure to the pump to ensure it is between 70-80 PSI (0.483 - 0.552 MPA)</p> <p>E. Check CO2 pressure and/or replace pump.</p> <p>F. Remove kink or replace line.</p> <p>G. Repair or replace CO2 regulator as required.</p>
4.17 Valve will not shut off.	<p>A. Debris in solenoid seat.</p> <p>B. Solenoid plunger sticking.</p>	<p>A. Activate valve a few times to free debris. Remove the solenoid coil and plunger and clean out foreign material.</p> <p>B. Replace solenoid coil.</p>
4.18 Syrup only dispensed. No water, but CO2 gas dispensed with syrup.	<p>A. Improper water flow to dispenser.</p> <p>B. Carbonator pump motor has timed out. (A message will be displayed on the LCD screen.)</p> <p>C. Liquid level probe not connected properly to PCB.</p> <p>D. Defective PCB assembly.</p> <p>E. Defective liquid level probe.</p>	<p>A. Check for water flow to dispenser.</p> <p>B. Reset by turning the unit off and then of by using the circuit breaker on the power supply, or momentarily unplugging unit.</p> <p>C. Check connections of liquid level probe to PCB assembly. Replace PCB assembly.</p> <p>D. Replace PCB assembly.</p> <p>E. Replace liquid level probe.</p>

TROUBLE	CAUSE	REMEDY
4.19 Excessive foaming.	<p>A. No ice in bin.</p> <p>B. Incoming water or syrup temperature too high.</p> <p>C. CO2 pressure too high.</p> <p>D. Water flow rate too high.</p> <p>E. Nozzle and diffuser not clean.</p> <p>F. Air in BIB lines</p>	<p>A. Fill bin with ice and allow coldplate to restabilize.</p> <p>B. Correct prior to dispenser.</p> <p>C. Adjust CO2 pressure downward, but not less than 70 PSI (0.483 MPA).</p> <p>D. Readjust and reset ratio.</p> <p>E. Remove and clean.</p> <p>F. Bleed air from BIB lines</p>
4.20 Water continually leaking at connections.	<p>A. Loose water connections.</p> <p>B. Flare seal washer leaks.</p>	<p>A. Tighten water connections.</p> <p>B. Replace flare seal washer</p>
4.21 Water leaking from ice door.	<p>A. Securing screws loosened.</p> <p>B. Ice door improperly seated.</p>	<p>A. Tighten screws.</p> <p>B. Reattach door assembly to dispenser.</p>
4.22 Circuit breaker tripping.	<p>A. Valve wire harnesses shorted to itself or faucet plate.</p> <p>B. Controller PCB is bad.</p> <p>C. Secondary wire harness is shorted.</p> <p>D. Power supply is bad.</p>	<p>A. Detect short by disconnecting valve harnesses from switch panel (2 25-pin harnesses and 2 9-pin harnesses). Restore power. If breaker does not trip, then find and replace shorted harness. If breaker still trips, reinstall the eight harnesses and proceed to Step B.</p> <p>B. Detect by disconnecting the white 5-pin harness from the controller PCB. Restore power. If breaker does not trip, then replace controller PCB. If breaker still trips, reinstall the white 5-pin harness and proceed to Step C.</p> <p>C. Locate short from a motor or solenoid harness and replace as necessary.</p> <p>D. Detect short by disconnecting all harnesses connected to power supply. Restore power. If breaker still trips, replace power supply.</p>
4.23 BIB pump does not operate when dispensing valve is opened.	<p>A. Out of CO2, CO2 not turned on, or low CO2 pressure.</p> <p>B. Out of syrup.</p> <p>C. BIB connector not tight.</p> <p>D. Kinks in syrup or gas lines.</p>	<p>A. Replace CO2 supply, turn on CO2 supply, or adjust CO2 pressure to 70-80 PSI (0.483 - 0.552 MPA).</p> <p>B. Replace syrup supply.</p> <p>C. Fasten connector tightly.</p> <p>D. Straighten or replace lines.</p>

TROUBLE	CAUSE	REMEDY
4.24 BIB pump operating, but no flow.	A. Leak in syrup inlet or outlet line. B. Defective BIB pump check valve.	A. Replace line. B. Replace BIB pump.
4.25 BIB pump continues to operate when bag is empty.	A. Leak in suction line. B. Leaking o-ring on pump inlet fitting. C. Defective syrup BIB pump.	A. Replace line. B. Replace o-ring. C. Replace defective pump.
4.26 BIB pump fails to restart after bag replacement.	A. BIB connector not on tight. B. BIB connector is stopped up. C. Kinks in syrup line.	A. Tighten BIB connector. B. Clean out or replace BIB connector. C. Straighten or replace line.
4.27 BIB pump fails to stop when dispensing valve is closed	A. Leak in discharge line or fittings. B. Empty BIB. C. Air leak on inlet line or bag connector.	A. Repair or replace discharge line. B. Replace BIB. C. Repair or replace.
4.28 Low or no carbonation.	A. Low or no CO ₂ . B. Low water pressure. C. Worn or defective carbonator pump. D. Backflow preventer not allowing water for flow. E. Probe malfunctioning. F. PCB malfunctioning.	A. Check CO ₂ supply. Adjust CO ₂ pressure to 70 PSI (0.483 MPA). B. Need water booster kit. C. Replace carbonator pump. D. Replace backflow preventer, noting the flow direction arrow from pump to coldplate. E. Replace probe. F. Replace PCB.

5. DISPENSER DISPOSAL



To prevent possible harm to the environment from improper disposal, recycle the unit by locating an authorized recycler or contact the retailer where the product was purchased. Comply with local regulations regarding disposal of the refrigerant and insulation.

6. ILLUSTRATIONS, PARTS LISTINGS AND WIRING DIAGRAMS

6.1 ICE CHUTE ASSEMBLY

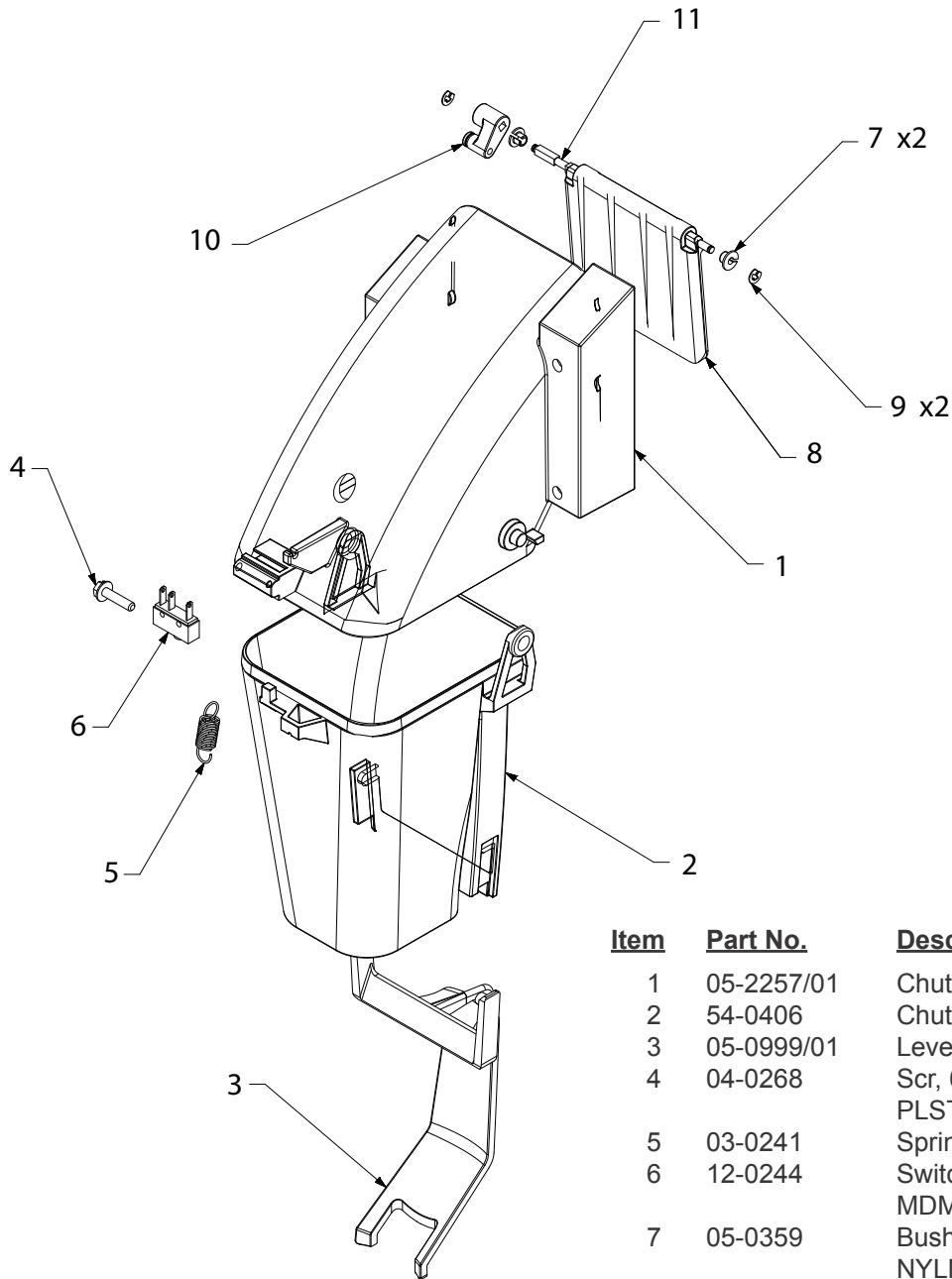

<u>Item</u>	<u>Part No.</u>	<u>Description</u>
1	05-2257/01	Chute, Upper, IC
2	54-0406	Chute, Printed, IBD
3	05-0999/01	Lever, Chute, IBD
4	04-0268	Scr, 6-19X.625 LG, PLSTI,HHSW/W
5	03-0241	Spring, Chute, IBD
6	12-0244	Switch, SPST, 5A, 250V, MDM
7	05-0359	Bushing, .123 ID x .187 OD, NYLN
8	05-0928/02	Trap Door, IBD
9	03-0113	Ring, Retaining
10	05-0546	Lever, Door
11	10-0732	Shaft, Ice Chute Door, IC

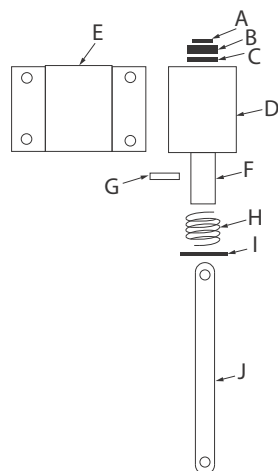

ICE DOOR SOLENOID ASSEMBLY (AT LEFT):

A	03-0086	Ring, Retaining (5304-18)
B	04-0328	Washer, Rubber
C	04-0327	Washer, Flat
D	12-0195	Solenoid, D-90
E	30-5165	Bracket, Solenoid
F	23-1380	Plunger Assy
G	10-0496	Pin, Solenoid Assy
H	03-0110	Spring, Solenoid
I	03-0111	Ring, Retaining (5133-62)
J	30-8356	Linkage, Door, FS

6.2 FINAL ASSEMBLY (FS 22)

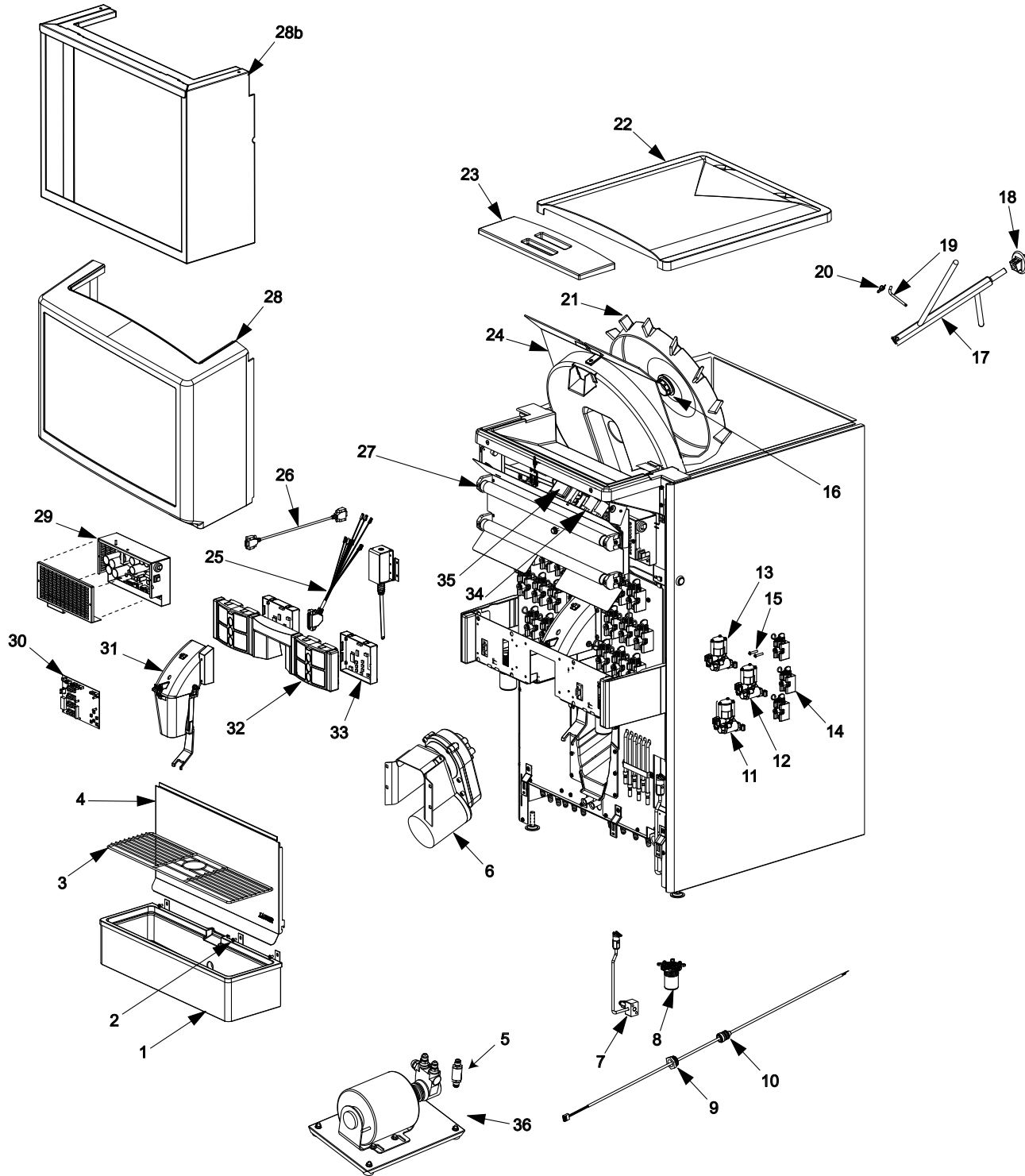

6.2 FINAL ASSEMBLY (FS 22) - PARTS LIST

<u>Part No.</u>	<u>Description</u>	<u>Part No.</u>	<u>Description</u>
85-14408-06-2	IBD, ACMB, 22", 150#, 8/6, LFCV, Cubed		
85-14408N-06-2	IBD, ACMB, 22", 150#, 8/6, LFCV, Pellet		
85-14408-06-2-711	IBD,FS22,150#,8/6,LED,115V,7-11		
85-14308-06-711	IBD,FS22,150, 8/6,230v,7-11		
85-14308-06-711-47	IBD,FS22,150, 8/6,230v,7-11,THAI		

<u>Item</u>	<u>Part No.</u>	<u>Description</u>	<u>Item</u>	<u>Part No.</u>	<u>Description</u>
1	82-3441/01	Drip Tray Assy, IBD22	20	03-0368	Retainer, Pin, Agitator, IBD
2	04-0236	Screw, 10-24 x 0.375, PHD, PH, MS, SS	21	82-3556	Dispensing Wheel Assy, Hex
3	23-0969/01	Cup Rest, Wire, 22", IBD	22	05-1467	Lid, Back, IBD22, RND
4	30-9194	Splash Plate, FS-8	23	05-1476/01	Lid, Front, IBD, RND
5	17-0611.	Check Valve, Vented, 5/8-18	24	05-1309/02-01	Shroud, Dispensing Wheel, MOD, IBD
6	82-3688/01	Motor Assy, Gear, 115V, 1/7HP, IBD	25	52-2985	Harness, Valve 25-pin, FS-16, Sealed
	91-0165/01	Motor, Agitator, 562, 115V, 4RPM, IBD	26	52-2686	Harness, Control-To-Valve, 9-pin, M/F, FS-8
	82-3834/01	Drive Assy, 230V	27	12-0146/01	Lamp, 18", 5W, T8, Daylight
	91-0178/01	Motor, Agitator, 230V		12-0643	LED, Light Bar, 18 in, 9.5w, 24VDC
7	82-3370	CO2 Assy, Inlet/P-Off, FS-16	28	82-3771	Merchandiser, Assy, FS-22
	54-0066	Relief Valve Assy, Plastic	-	06-2994-02	Graphic, FS-22, Brilliant Yellow
8	54-0289	Nozzle Assy, Multi-Flavor	28B	82-4503	Divider Assy, Graphic, 7-11, 22 Merch.
9	01-2214	Nut, Swivel, Probe, Carb, FS-16		51-6653	Merch, Assy, FS22, 7-11 INT
10	52-2751/02	Probe Cord Assy, Carb, FS-16	-	06-3328	Panel, Graphic, FS22,7-11, Metal, Merch
11	82-3820	Valve Assy, LFCV, .2 Syrup Injection, Natural (Spare with Adapter)	-	06-3313	Panel, Graphic, FS22, 7-11, Price Strp
12	82-3824	Valve Assy, LFCV, 3.0 - 4.5, Soda/Water, Gray (Spare with Adapter)	29	82-3664	Assy, Power Supply, FS-8
				82-3910/01	Assy, Power Supply, FS-8, 230 V
13	82-3823	Valve Assy, LFCV, 3.0 - 4.5, Syrup, Black (Spare with Adapter)	30	52-2820/01	PCB Assy, FS-IBD Controller Board
14	82-2317/01	Block Mounting Assy, SGL	31	82-3538/01	Ice Chute Assy, IBD30, Pellet
15	04-1089	Screw, 10-32 x 1.000, RH, PH/SL	32	05-2058	Bezel, M-Brand, 2L/2R
16	02-0406/01	Seal, Shaft, Motor, IBD	33	82-3630	Switch Assy, FS, 2L/2R
17	23-1373	Agitator Assy, FS/IBD, HEX	34	12-0104	Starter, with Condenser, IBD
18	54-0472	Bearing, Agitator, Rear, IBD		12-0644	Ballast, LED Driver, 20w, 24v
19	10-0762	Pin, Hex Design, FS-16	35	12-0188	Ballast, Fluorescent Light, LC-14-20-C
			36	82-3791	Pump Assy, Remote, FS22, 1/3 HP
				86-0084	Pump Assy
				91-0008	Motor, Carb 1/3 HP
				82-3906	Pump Kit, REM, FS22/44, 230V, 50/60
				82-3905	Pump Assy, REM, FS22, 230V, 50/60
				82-3904	Motor Assy, REM, FS22, 230V, 50/60

6.3 PELLET ICE ASSEMBLY AND PARTS LISTING

Use the components listed on this page with pellet ice only.

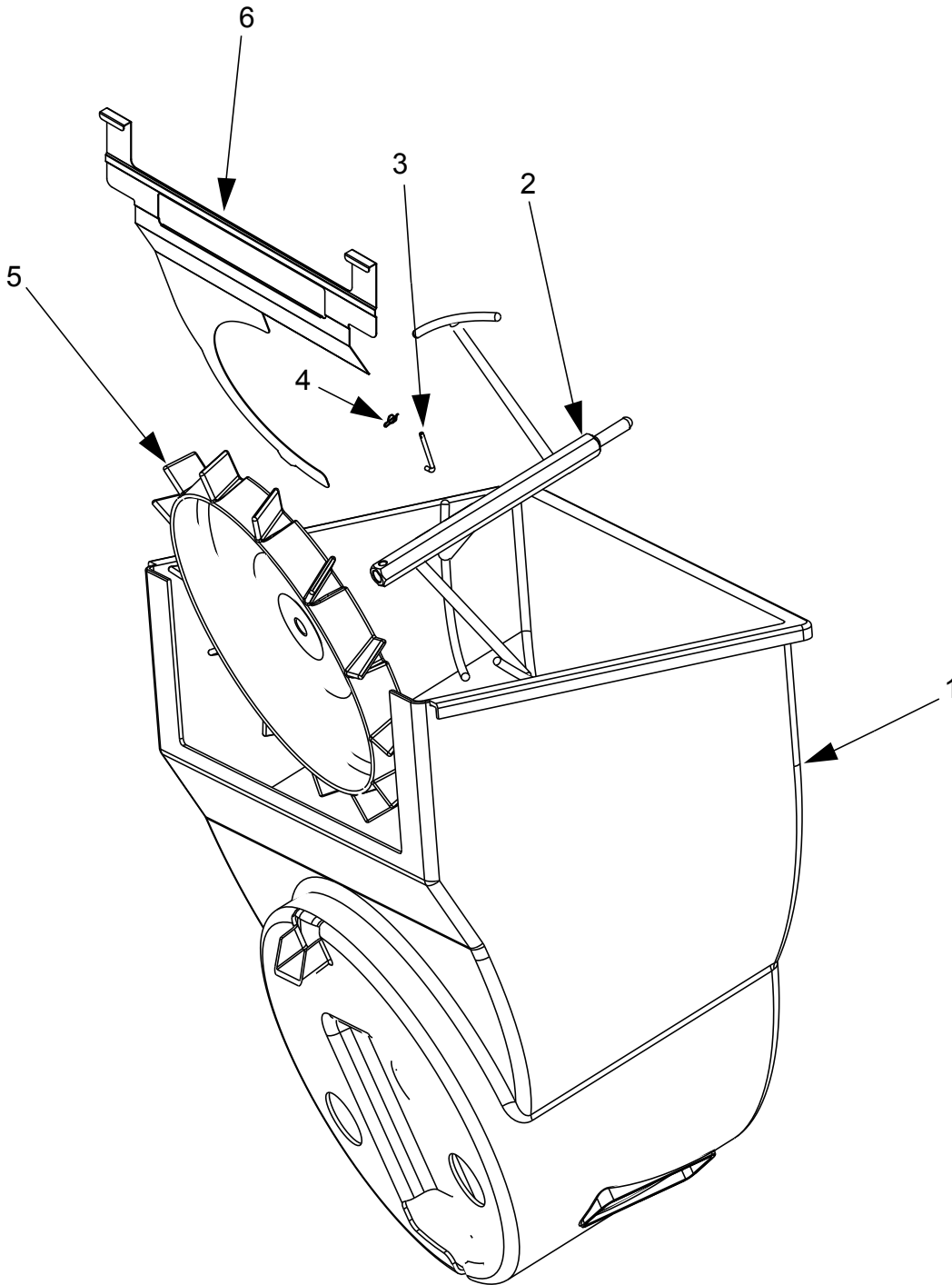

<u>Item</u>	<u>Part No.</u>	<u>Description</u>
1	05-2325/01	Ice Shroud, IC
2	23-1401/01	Agitator Assy, Helical, IC
3	10-0762	Pin, Hex Design, FS-16
4	03-0368	Retainer, Pin, Agitator, IBD
5	82-3651	Dispensing Wheel Assy, Pellet Ice
6	30-9801/01	Shield, Nugget, I

6.4 LANCER FLOW CONTROL VALVE (LFCV)

LFCV VALVE ASSEMBLIES

<u>Item</u>	<u>Description</u>
82-3820	LFCV, BONUS INJECTOR
82-3823	LFCV, 3.0 - 4.5, SYRUP ASSY
82-3824	LFCV, 3.0 - 4.5, SODA/WATER ASSY

Valve Assembly

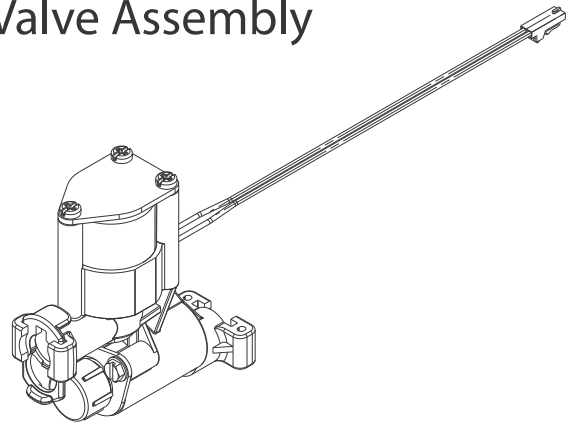

LFCV SPARE PARTS

<u>Item</u>	<u>Part No.</u>	<u>Description</u>
1	10-0430/05	PLUG NUT
2	02-0538	O-RING
3	12-0364/04-01	COIL, LFCV
4	23-1301/01	CORE SEAL ASSY
5	03-0180/02	SPRING, CORE
6	02-0109	O-RING
7	05-1745/02	SEAT, LFCV
8	02-0133	O-RING

Spare Parts

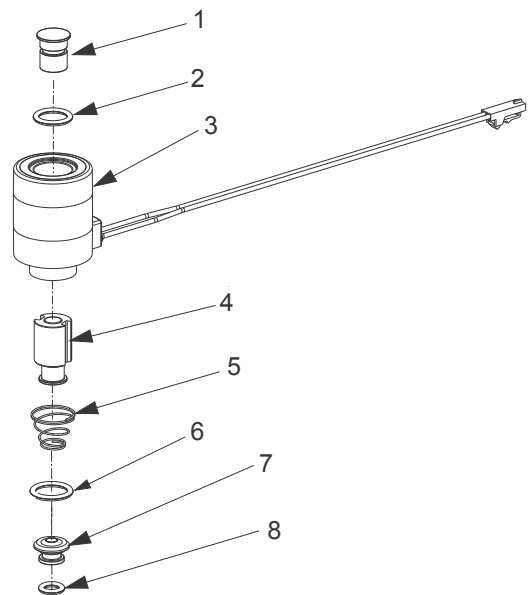

LFCV KIT

82-4020	LFCV REBUILD KIT
---------	------------------

FS22

WIRING DIAGRAM

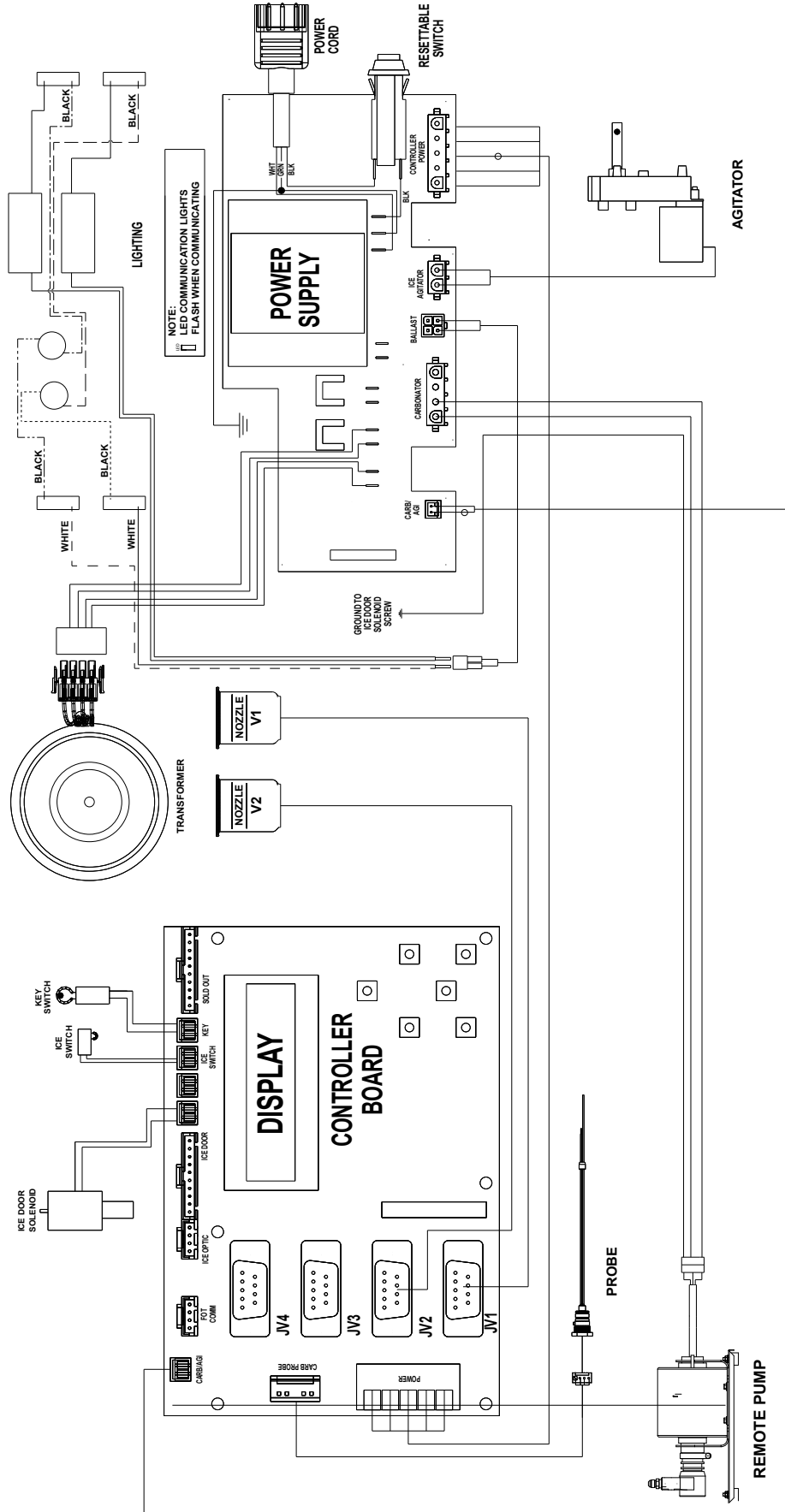

6.6 PLUMBING DIAGRAM WITH VALVE WIRING

VALVE HARNESS DIAGRAM



V
A
L
V
E

M
O
U
N
T
I
N
G

N
O
Z
Z
L
E

P
A
N
E
L

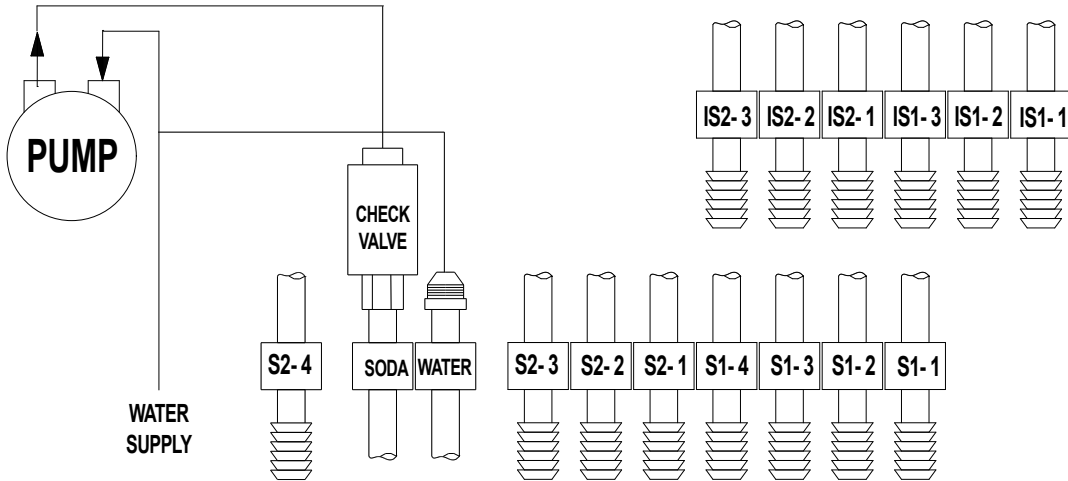
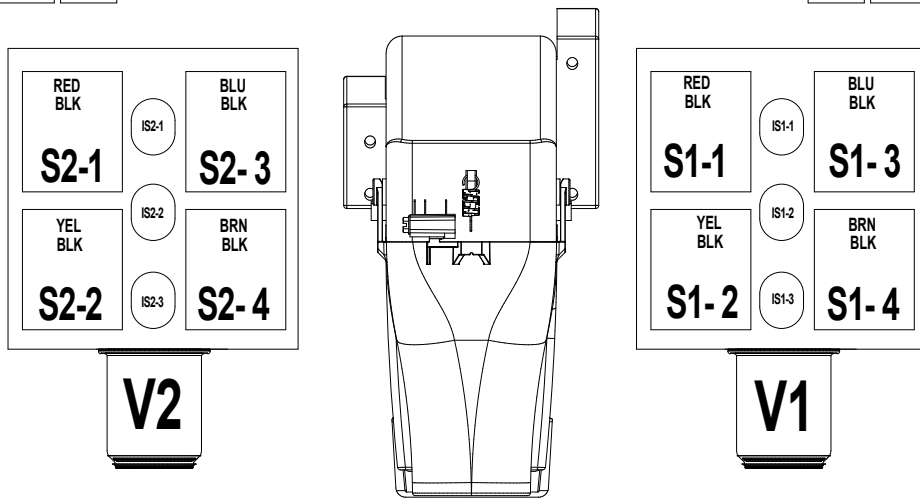

I
N
L
E
T

F
I
T
T
I
N
G
S

PLUMBING DIAGRAM

6.7 WIRING DIAGRAM/PLUMBING DIAGRAM - FS22 INTERNATIONAL

WIRING DIAGRAM

FS22 7-11

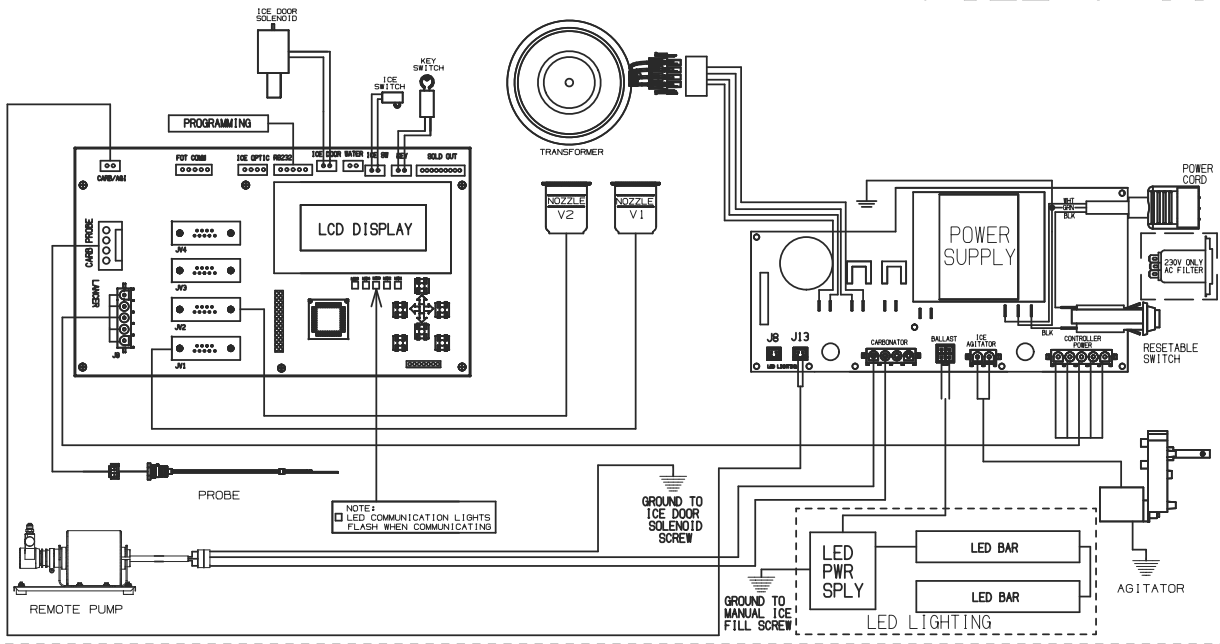

VALVE HARNESS DIAGRAM

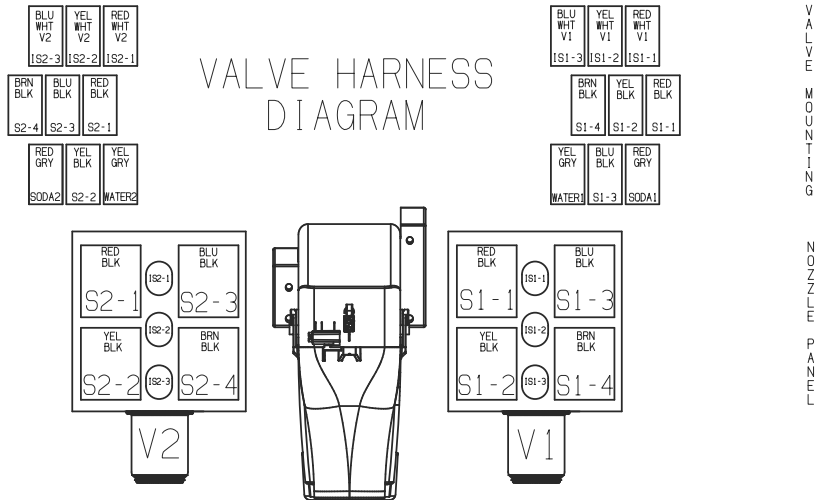

PLUMBING DIAGRAM

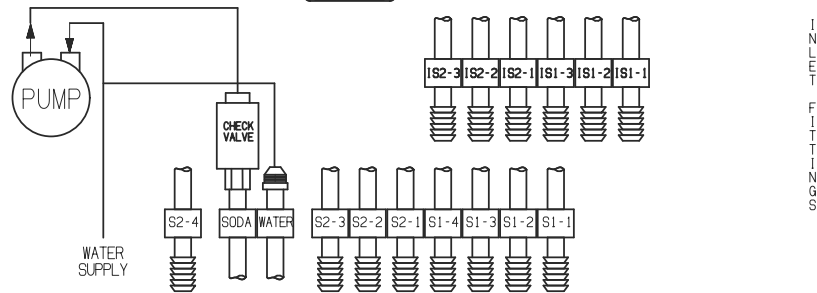

06-3541

FS22 COUNTER CUTOUT

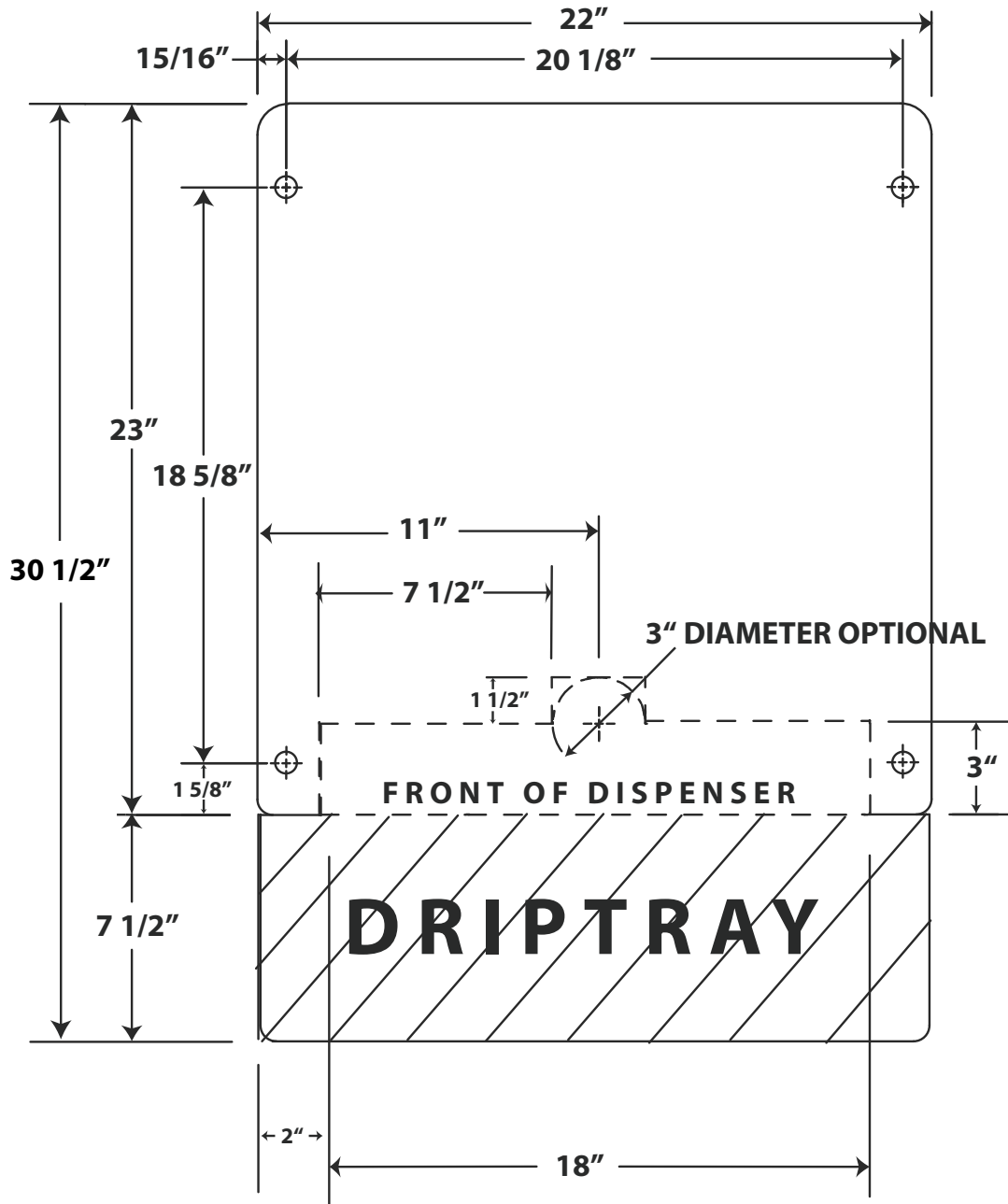

--- CUT OUT DASHED AREA

⊕ OPTIONAL HOLES FOR FASTENING DISPENSER TO COUNTER WITH SCREWS

LANCER[®]

Lancer Corp.

800-729-1500

Technical Support/Warranty: 800-729-1550

custserv@lancercorp.com

lancercorp.com