

LANCER®

CED Series 2500



Operation Manual

Lancer Corporation
6655 Lancer Blvd.
San Antonio, Texas 78219
800-729-1500



Technical Support/Warranty
800-729-1550
custserv@lancercorp.com
lancercorp.com
PN: 28-0089/06

"Lancer" is the registered trademark of Lancer © 2016 by Lancer, all rights reserved.

TABLE OF CONTENTS

ABOUT THIS MANUAL

This booklet is an integral and essential part of the product and should be handed over to the operator after the installation and preserved for any further consultation that may be necessary. Please read carefully the guidelines and warnings contained herein as they are intended to provide the user with essential information for the continued safe use and maintenance of the product. In addition, it provides **GUIDANCE ONLY** to the user on the correct services and site location of the unit.

The installation and relocation, if necessary, of this product must be carried out by qualified personnel with up-to-date safety and hygiene knowledge and practical experience, in accordance with current regulations.

IMPORTANT SAFETY INSTRUCTIONS.....	3-4
Intended Use.....	3
Power Warning.....	3
CO ₂ Warning.....	3
Water Notice.....	3
Agitation Warning.....	4
SPECIFICATIONS AND FEATURES.....	4-5
General System Overview.....	5
PRE-INSTALLATION CHECKLIST.....	5
INSTALLATION.....	6-10
Unpacking the Dispenser.....	6
Selecting/Preparing a Counter Location.....	6
Dispenser Installation.....	7-8
Installing Remote Syrup Pumps - BIB.....	8
Connecting to Syrup Supply - BIB.....	9
Installing CO ₂ Supply / Dispenser Setup.....	9-10
Adjust Water Flow Rate & Syrup/Water Ratio.....	10

BEFORE GETTING STARTED

Each unit is tested under operating conditions and is thoroughly inspected before shipment. At the time of shipment, the carrier accepts responsibility for the unit. Upon receiving the unit, carefully inspect the carton for visible damage. If damage exists, have the carrier note the damage on the freight bill and file a claim with carrier. Responsibility for damage to the dispenser lies with the carrier.

MAINTENANCE.....	11
Scheduled Maintenance.....	12
CLEANING AND SANITIZING.....	11-12
General Information.....	11
Cleaning and Sanitizing Solutions.....	12
Cleaning and Sanitizing Syrup Lines.....	12
Cleaning and Sanitizing Nozzles.....	12
TROUBLESHOOTING.....	13-17
THE ELECTRONIC ICE BANK CONTROL (EIBC).....	18
Checking the Normal PCB Operation.....	18
ILLUSTRATIONS AND PART LISTINGS.....	19-29
Installation Kits and Optional Accessories.....	19
Cabinet Assembly.....	20-21
Refrigeration Deck Assembly - USA.....	22-23
Refrigeration Deck Assembly - International.....	24-25
Control Housing Assembly - International.....	26-27
Wiring Diagram - USA.....	28
Control Housing Connections.....	28
Wiring Diagram - International.....	29
Plumbing Diagram - 8 Valve and 6 Valve.....	29

SAFETY NOTICES

READ ALL SAFETY INSTRUCTIONS BEFORE USING THIS UNIT.

This manual contains important safety information and all applicable safety precautions must be observed. To reduce the risk of fire, electric shock, damage to the equipment or personal injury when using this unit all instructions/warnings on the product being used must be followed:

⚠ WARNING

Text following the Warning signal indicates a hazardous situation, which if not avoided, will result in death or serious injury. Be sure to read all Warning statements before proceeding with the installation.

⚠ CAUTION

Text following the Caution signal indicates a hazardous situation, which if not avoided, could result in death or serious injury. Be sure to read the Caution statements before proceeding with the installation

⚠ ATTENTION

Text following the Attention signal addresses a situation that if not followed could potentially damage the equipment. Be sure to read the Attention statements before proceeding

NOTE

Text following the Note signal provides you with information that may help you more effectively perform the installation procedures within this manual. Disregarding information will not cause damage or injury, however it may limit the performance of the dispenser.

IMPORTANT SAFETY INSTRUCTIONS

Intended Use

- The dispenser is for indoor use only
- This appliance is intended to be used in commercial applications such as restaurants or similar.
- This appliance should not be used by children or infirm persons without supervision.
- This appliance is not intended for use by persons (including children) with reduced physical, sensory or mental capabilities, or lack of experience and knowledge, unless they have been given supervision or instruction concerning use of the appliance by a person responsible for their safety.
- This appliance can be used by children aged from 8 years and above and persons with reduced physical, sensory or mental capabilities or lack of experience and knowledge if they have been given supervision or instruction concerning use of the appliance in a safe way and understand the hazards involved.
- Cleaning and user maintenance shall not be performed by children without supervision.
- This unit is not a toy and children should be advised not to play with the appliance.
- The min/max ambient operating temperature for the dispenser is 40°F to 90°F (4°C to 32°C).
- Do not operate unit below minimum ambient operation conditions.
- Should freezing occur, cease operation of the unit and contact authorized service technician.
- The maximum tilt for safe operation is 5°.
- This appliance must be installed and serviced by a professional.

Carbon Dioxide (CO₂)

- **WARNING:** Carbon Dioxide (CO₂) is a colorless, noncombustible gas with a light pungent odor. High percentages of CO₂ may displace oxygen in the blood.
- **WARNING:** Prolonged exposure to CO₂ can be harmful. Personnel exposed to high concentrations of CO₂ gas will experience tremors which are followed by a loss of consciousness and suffocation.
- **WARNING:** If a CO₂ gas leak is suspected, immediately ventilate the contaminated area before attempting to repair the leak.
- **WARNING:** Strict attention must be observed in the prevention of CO₂ gas leaks in the entire CO₂ and soft drink system.

Power

- Follow all local electrical codes when making connections.
- Check the dispenser name plate label, located behind the splash plate for correct electrical requirements of unit. **DO NOT** plug into a wall electrical outlet unless the current shown on the serial number plate agrees with local current available.
- Each dispenser must have a separate electrical circuit.
- **DO NOT** use extension cords with this unit.
- **DO NOT** 'gang' together with other electrical devices on the same outlet.
- **WARNING:** Always disconnect electrical power to the unit to prevent personal injury before attempting any internal maintenance.
- The resettable breaker switch should not be used as a substitute for unplugging the dispenser from the power source to service the unit.
- Only qualified personnel should service internal components of electrical control housing.
- **WARNING:** Make sure that all water lines are tight and units are dry before making any electrical connections
- If this dispenser is installed in an area that is susceptible to ±10% variation of the nominal line voltage, consider installing a surge protector or similar protection device.

Water Notice

- Provide an adequate, potable water supply. Water pipe connections and fixtures directly connected to a potable water supply must be sized, installed, and maintained according to federal, state, and local codes.
- The water supply line must be at least a 3/8 inches (9.525 mm) pipe with a minimum of 25 PSI (0.172 MPA) line pressure, but not exceeding a maximum of 50 PSI (0.345 MPA). Water pressure exceeding 50 PSI (0.345 MPA) must be reduced to 50 PSI (0.345 MPA).
- Use a filter in the water line to avoid equipment damage and beverage off-taste. Check the water filter periodically, as required by local conditions.
- **CAUTION:** The water supply must be protected by means of an air gap, a backflow prevention device (located upstream of the CO₂ injection system) or another approved method to comply with NSF standards. A leaking inlet water check valve will allow carbonated water to flow back through the pump when it is shut off and contaminate the water supply.
- **CAUTION:** Ensure the backflow prevention device complies with ASSE and local standards. It is the responsibility of the installer to ensure compliance.

! Automatic Agitation

- Units are equipped with an automatic agitation system and will activate unexpectedly.
- **CAUTION:** Do not place hands or foreign objects in the water bath tank. Unplug the dispenser during servicing, cleaning, and sanitizing.
- **CAUTION:** To avoid personal injury, do not attempt to lift the dispenser without assistance. For heavier dispensers, use a mechanical lift.

SPECIFICATIONS AND FEATURES

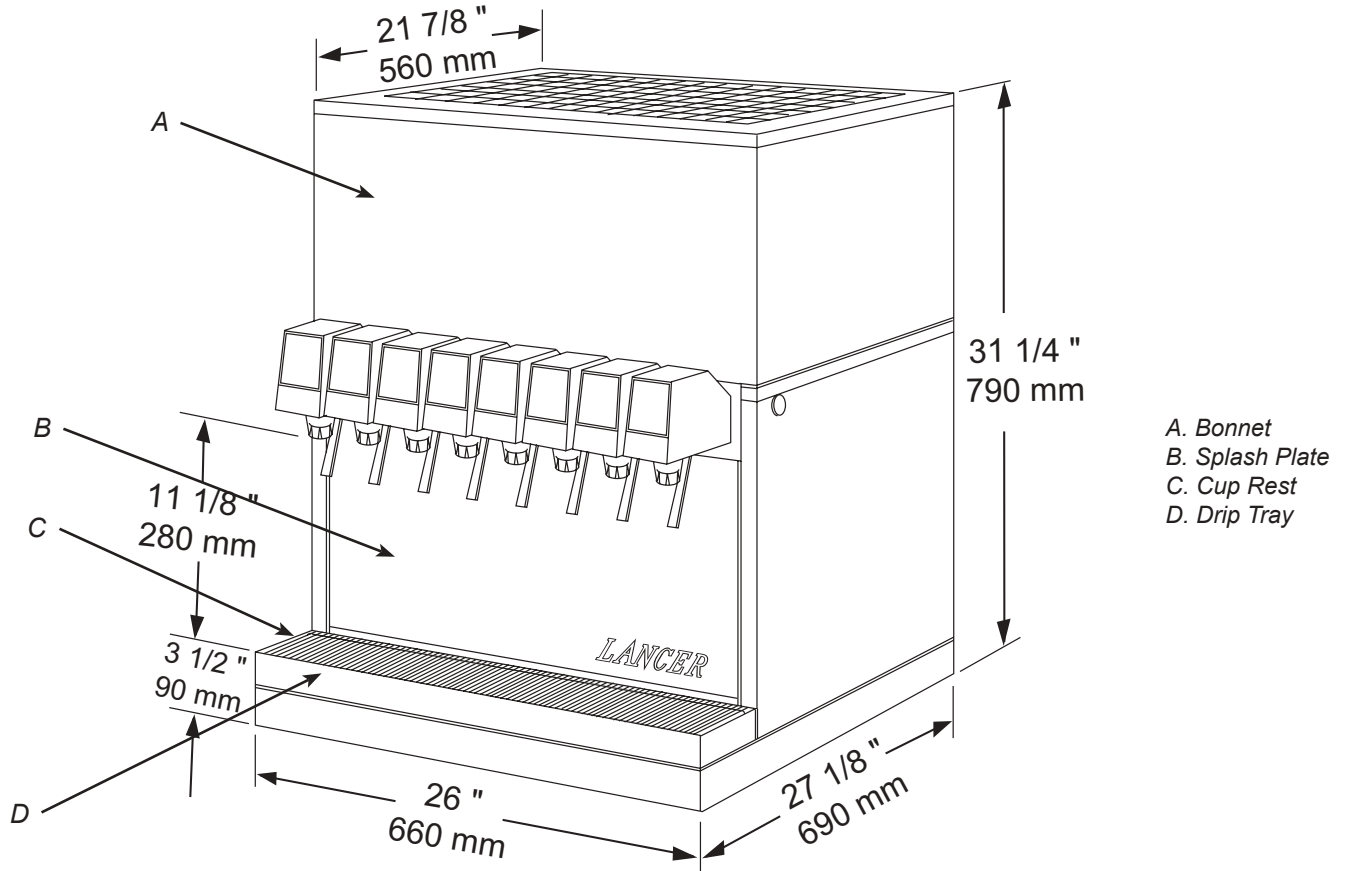

DIMENSIONS

Width: 26 inches (660 mm)
Depth: 27.13 inches (690 mm)
Height (w/out legs): 31.25 inches (790 mm)

WEIGHT

Shipping: 257 lbs (117 kg)
Empty: 209 lbs (95 kg)
Operating: 376 lbs (171 kg)

ELECTRICAL

115 VAC / 60 Hz / 4.3 Amps
230-240 VAC / 50-60 Hz / 2.6 Amps

ICE BATH

Capacity: 50.0 lbs (23 kg)

PLAIN WATER SUPPLY

Min Flowing Pressure: 25 PSIG (0.172 MPA)
Max Static Pressure: 50 PSI (0.345 MPA)

CARBON DIOXIDE (CO₂) SUPPLY

Min Pressure: 70 PSIG (0.483 MPA)
Max Pressure: 80 PSIG (0.552 MPA)

FITTINGS

Water for Carb Inlet: 3/8 inch barb
Brand Syrup Inlets: 3/8 inch barb
Carb CO₂ Inlet: 3/8 inch barb

This unit emits a sound pressure level below 70 dB

General System Overview

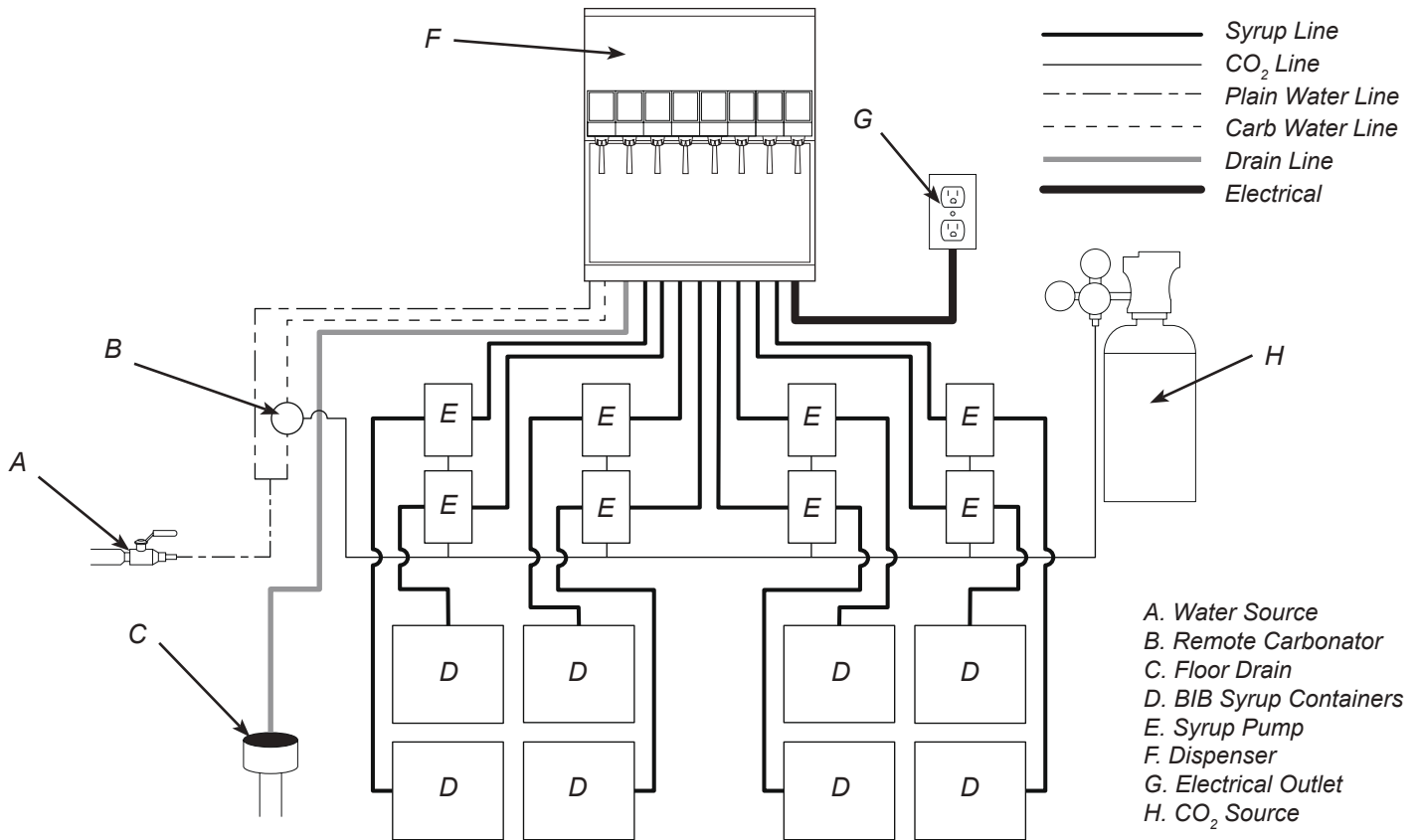

PRE-INSTALLATION CHECKLIST

TOOLS REQUIRED:

- Oetiker Pliers
- Tubing Cutters
- Wrench
- Slotted Screwdriver
- Phillips Screwdriver
- Drill

BIB SYSTEM:

- BIB Rack
- BIB Syrup Boxes
- BIB Regulator Set
- BIB Connectors

POST MIX ACCESSORIES:

- CO₂ Regulator
- CO₂ Supply
- Chain for CO₂ Tank
- Beverage Dispenser
- Beverage Tubing
- Oetiker Clamp Fittings
- Water Booster (Lancer PN: 82-3401 or MC-163172)
- Water Regulator (recommended)

CONSIDER THE FOLLOWING BEFORE INSTALLATION:

- Location of Water Supply Lines
- Location of Drain
- Location of Electrical Outlet
- Location of Heating and Air Conditioning Ducts
- Do you have enough space to install the dispenser?
- Is countertop level?
- Can the countertop support the weight of the dispenser?
- Is dispenser located away from direct sunlight or overhead lighting?
- Not in area where water jet could be used.

Read This Manual

This manual was developed by Lancer Corporation as a reference guide for the owner/operator and installer of this dispenser. Please read this manual before installation and operation of this dispenser. Please see pages 13-17 for troubleshooting or service assistance. If the service cannot be corrected please call your Service Agent or Lancer Customer Service. Always have your model and serial number available when you call.

INSTALLATION

Unpacking the Dispenser

1. Remove top portion of carton by lifting up.
2. Remove top inner carton pad and corners.
3. Remove accessory kit of loose parts from drip tray.
4. Lift unit up by plywood shipping base and remove lower portion of carton.

NOTE

Inspect unit for concealed damage. If evident, notify delivering carrier and file a claim against the same.

5. Remove splash plate.

NOTE

Splash plate is located under unit on shipping base for Series 1500E models only

6. Remove plywood shipping base from unit by moving unit so that one side is off the counter top or table allowing access to screws on the bottom of the plywood shipping base.

NOTE

If unit is to be transported, it is advisable to leave the unit secured to the plywood shipping base.

7. If leg kit has been provided, assemble legs by tilting unit.

⚠ ATTENTION

DO NOT LAY UNIT ON ITS SIDE OR BACK. DO NOT USE DRIP TRAY FRAME FOR A HANDLE.

8. Remove accessory kit of loose parts from drip tray.

Selecting/Preparing a Counter Location

1. The dispenser is designed to sit on a flat, supported surface capable of supporting a minimum weight of 400 lbs (182 kg). Select a location that is in close proximity to a properly grounded electrical outlet, within five (5) feet (1.5 m) of a drain, and a water supply that meets the requirements shown in the Specifications section found on page 4.
2. Select a location for the syrup pumps, CO₂ tank, syrup containers, water filter (recommended), and remote carbonator. Please see General System Overview on page 5 for reference.
3. The dispenser may either be counter or leg mounted. When the dispenser is to be permanently bolted to the counter top, use Lancer Sealant Kit (PN 15-0010) to seal dispenser base to counter top.

NOTE

NSF listed units must be sealed to the counter or have four (4) inch legs installed.

4. Condenser air is drawn in from the back grill located on the bonnet and discharged out the top of the bonnet. A minimum of fifteen (15) inches (380 mm) of clearance must be maintained over the top of the unit and a minimum of six (6) inches (152 mm) clearance behind the unit to provide for proper air flow and circulation.

⚠ ATTENTION

Failure to maintain specified clearance will cause the compressor to overheat and will result in compressor failure

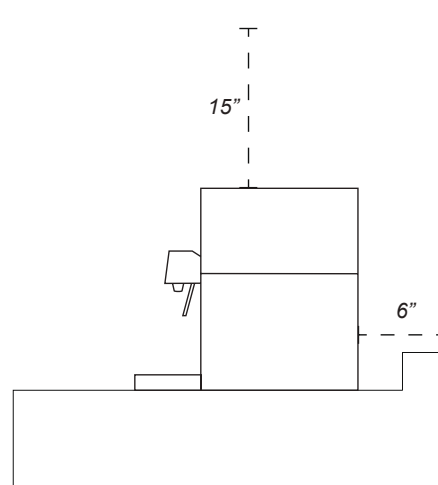

5. Cut the necessary holes in counter for mounting in the designated dispenser location, using the template provided.

Dispenser Installation

1. Install the unit onto the counter.
2. Remove the bonnet from the dispenser by lifting up.
3. Remove the drip tray from the unit and connect the drain tube to the drain fitting located on the bottom. Secure drain tube with clamp provided in accessory kit.
4. Route the drain tube to a suitable drain and replace the unit's drip tray.
5. Route appropriate tubing from the syrup pump location to the syrup inlets. Connect tubing to inlets using the oetiker pliers and fittings. Repeat for all syrup connections.

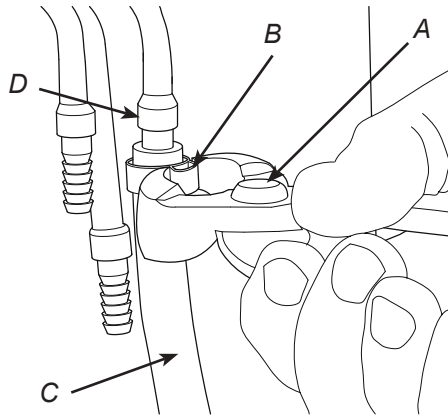

A. Oetiker Pliers
B. Fitting
C. Tubing
D. Syrup/Water/
CO₂ Inlet

6. Install remote carbonator per manufacturer's instructions.
7. Route appropriate tubing from the water source to the compressor deck fill hole, identified by the yellow cap, and **ONLY** connect tubing to water source.

NOTE

Leave 12 inches (305 mm) of extra tubing below the counter for servicing and moving the dispenser

8. Flush water supply line thoroughly.

⚠ CRITICAL - to maximize performance

Carefully read this before filling the water bath tank. In order to optimize the maximum performance of the dispenser, the following **MUST** be adhered to:

9. Insert water line into a large bucket, and fill with approx. 5.4 gallons (20.4 L) of distilled water.
10. Add 1/8 oz (4 g) of baking soda to distilled water and stir.

⚠ ATTENTION

For proper function of the electronic ice bank control the total dissolved solids (TDS) measurements should be 300-500 ppm.

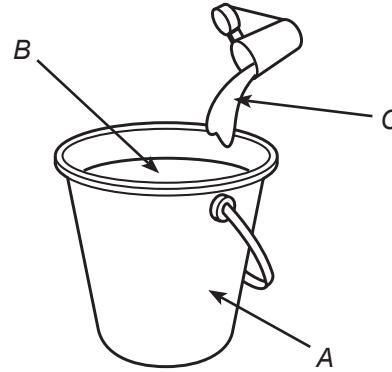

A. Bucket
B. Distilled Water
(approx. 5.4 gal)
C. Baking Soda
(approx. 1/8 oz)

11. Using a conductivity meter, measure the electric conductivity of the distilled water mixture.

⚠ ATTENTION

The E.C. measurement of the distilled water mixture must be between 100 and 300 uS/cm. Below 100 uS/cm, the compressor will not work properly and above 300 uS/cm could cause the lines to freeze.

12. Remove yellow cap from the water bath fill hole and insert and insert a funnel into the fill hole.
13. Remove the insulation strip from front of the refrigeration deck.
14. Carefully pour the distilled water mixture into the water bath tank until water flows out of the overflow tube at the front of the unit. (Repeat steps 9-11 if needed)

⚠ ATTENTION

The water bath compartment must be filled with water before plugging in the unit, otherwise the compressor fan may not operate properly.

15. Replace yellow cap, replace insulation, then connect water line to the water inlet in the front of the unit.

NOTE

Valves 4, 5, and 6 through 8 (on 8 valve units) and valves 3, 4, and 5 (on 6 valve units) have optional plain water or carbonated water capabilities. Use the Plumbing Diagram on page 29 to determine which valves are to be plumbed with plain water or carbonated water.

NOTE

Leave 12 inches (305 mm) of extra tubing below the counter for servicing and moving the dispenser

16. Route appropriate tubing from the syrup pump location to the carbonator CO₂ inlet and connect tubing to CO₂ inlet.
17. Re-attach splash plate and cup rest.
18. Plug in power cord to the unit control box.

19. Feed all tubing, power cord, and drain line through the counter top cutout.

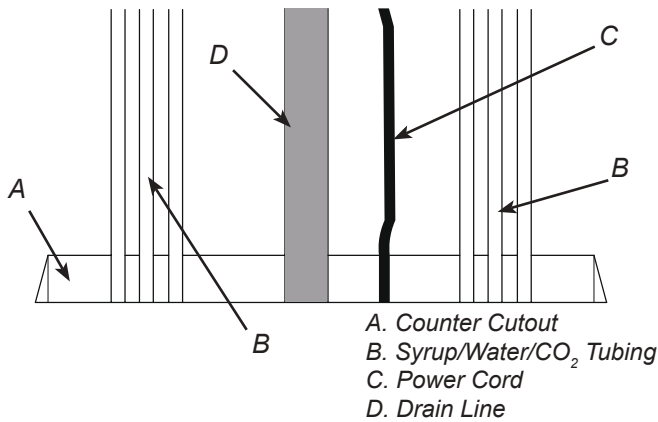

20. Plug in the unit to a grounded electrical outlet then turn the unit on to begin building an ice bank.

⚠ WARNING

The dispenser must be properly electrically grounded to avoid serious injury or fatal electrical shock. The power cord has a three-prong grounded plug. If a three-hole grounded electrical outlet is not available, use an approved method to ground the unit. Follow all local electrical codes when making connections. Each dispenser must have a separate electrical circuit. Do not use extension cords. Do not connect multiple electrical devices on the same outlet.

Installing Remote Syrup Pumps - Bag In Box

1. Install BIB rack and remote pumps according to manufacturers' instructions.
2. Once pumps and BIB rack are installed, measure and cut tubing to length between the pump CO₂ inlets, then connect tubing to all pumps.
4. Cut tubing from CO₂ supply to tee fitting at syrup pumps and install another tee fitting.
5. Attach line from carbonator CO₂ inlet to tee fitting between syrup pumps and CO₂ supply.

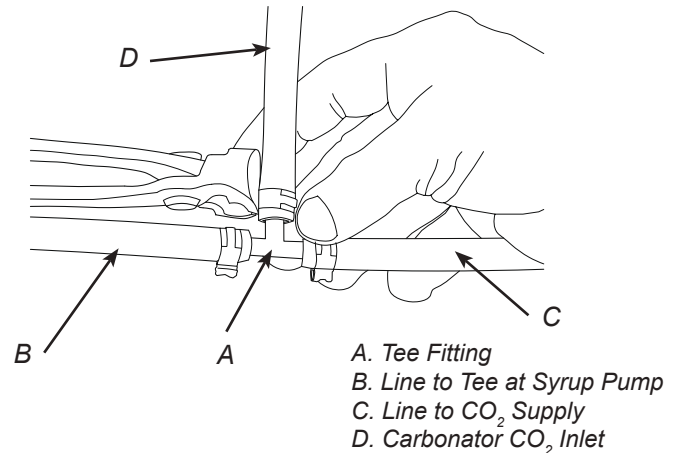
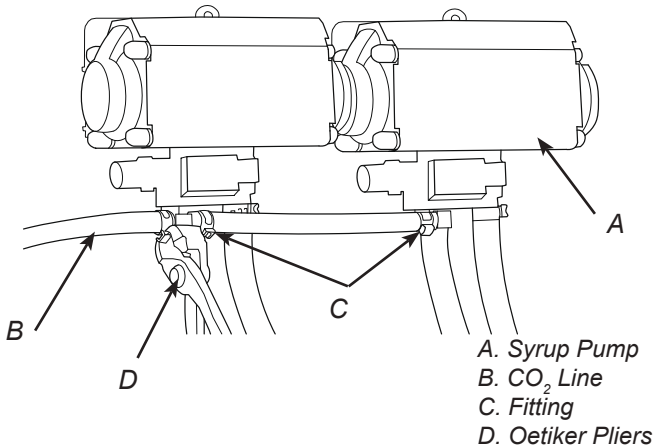

3. Using tubing cutters, cut any pump CO₂ supply line and install tee fitting, then route appropriate tubing from the CO₂ supply to the tee fitting at syrup pumps.

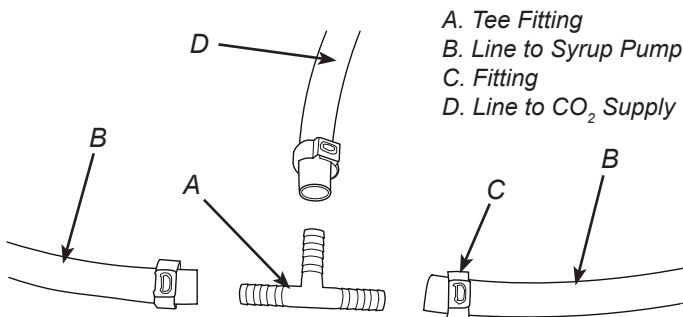

6. Connect tubing from dispenser syrup inlet to the syrup pump outlet fitting. Repeat for each syrup line/pump.

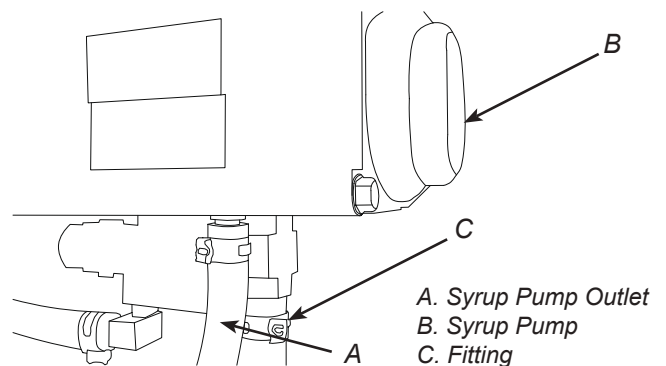

Connecting to Syrup Supply - Bag In Box

1. Install BIB (bag in box) connectors onto the syrup pump inlet tubing.

⚠ ATTENTION

Use proper connector for syrup manufacturer

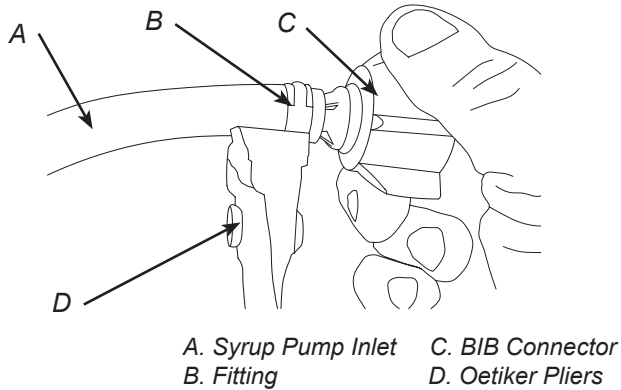

2. Connect syrup BIBs to connectors. Repeat for each syrup line/pump and each flavor injector line/pump.

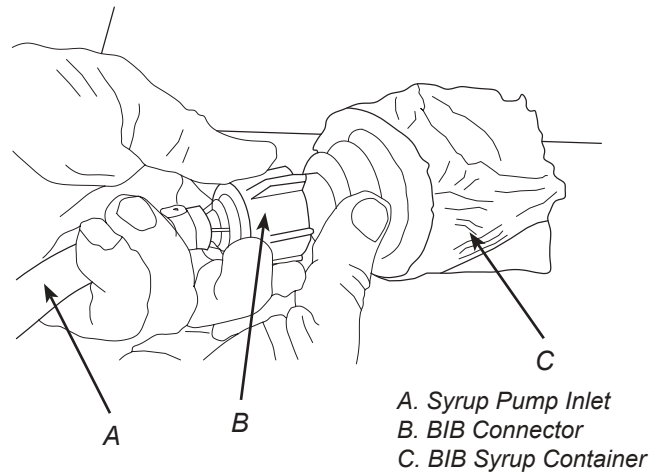

Installing CO₂ Supply / Dispenser Setup

1. Connect high pressure CO₂ regulator assembly to CO₂ cylinder or bulk system.

⚠ ATTENTION

Before installing regulator, assure that a seal (washer or o-ring) is present in regulator attachment nut.

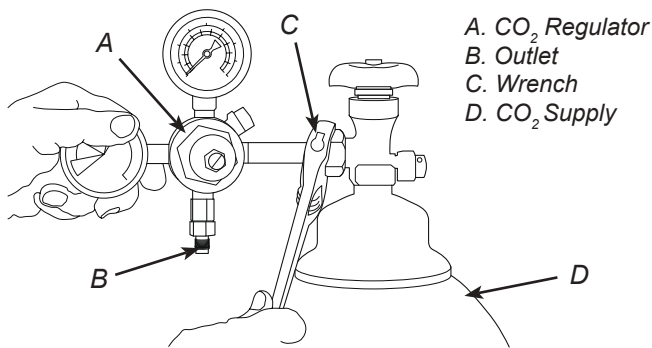

- Thread regulator nut on to tank, then tighten nut with wrench

2. Connect a 1/4" nut, stem and seal to CO₂ regulator outlet. Then connect tubing routed from tee at syrup pumps.

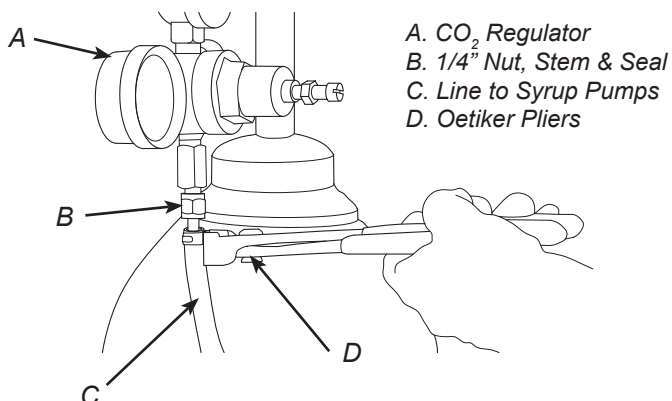

3. Using a wrench, loosen lock nut on regulator adjustment screw then using a screwdriver back out lock nut screw all the way.

⚠ WARNING

DO NOT TURN ON CO₂ SUPPLY AT THIS TIME

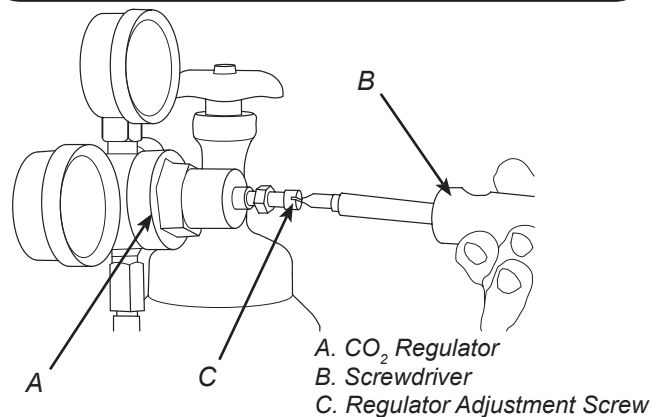

4. Turn on water source then purge water to fill carbonator tank by opening carbonator relief valve. Close relief valve once water comes out.
5. Activate each valve until a steady flow of water is achieved.
6. Unplug the unit then unplug the Pump Motor Connector from the control box. Use the wiring diagram either on the unit control box or in the back of this manual for reference.

⚠ ATTENTION

Failure to disconnect the motor power supply will damage the carbonator motor, the pump and void the warranty

7. Turn on CO₂ and using a screwdriver, adjust regulator to 75 PSI (0.517 MPA) then tighten lock nut with wrench.

8. Activate each valve until gas-out is achieved.
9. Plug the Pump Motor Connector back into the control box then plug in unit.

NOTE

Pump Motor will run for a few seconds to fill carbonator tank

10. Re-attach bonnet.
11. Activate each valve until a steady flow of carbonated water is achieved.

Adjust Water Flow Rate & Syrup / Water Ratio

NOTE

The water flow can be adjusted between 1.25 oz/sec (37 ml/sec) and 2.50 oz/sec (74 ml/sec) on all dispensing valves using the following procedures:

NOTE

The refrigeration unit should have been running for at least one (1) hour before attempting to set flow rates on valves. The drink temperature should be no higher than 40°F (4.4°C) when flow rates are set. This is best done after the unit has already made an ice bank.

1. Close syrup shut-off at mounting block for first valve.

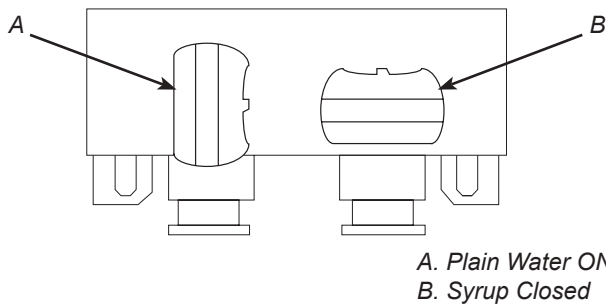

2. Slide up on ID panel until flow controls are exposed.
3. Using a Lancer ratio cup verify water flow rate (5 oz. in 4 sec.). Use a screwdriver to adjust if needed.

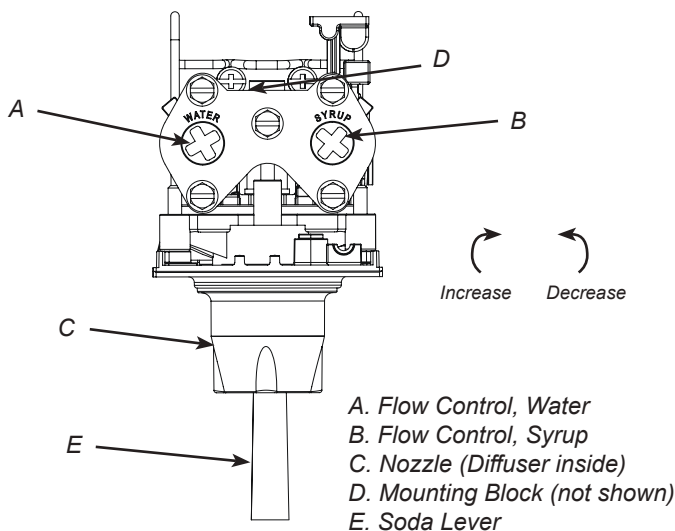

4. Remove nozzle by twisting counter clockwise and pulling down, then remove diffuser by pulling down.
5. Install Lancer (yellow) syrup separator (PN 54-0031) in place of nozzle.

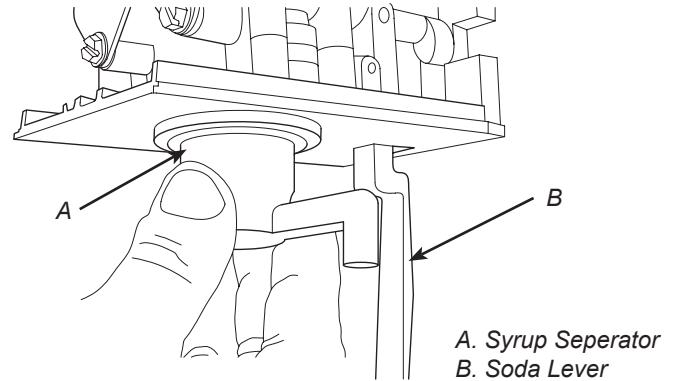

6. Re-open syrup shut-off at mounting block.
7. Activate valve to purge syrup until steady flow is achieved.
8. Using a Lancer ratio cup, activate the valve and capture a sample. Verify that the syrup level is even with the water level. Use a screwdriver to adjust if needed.

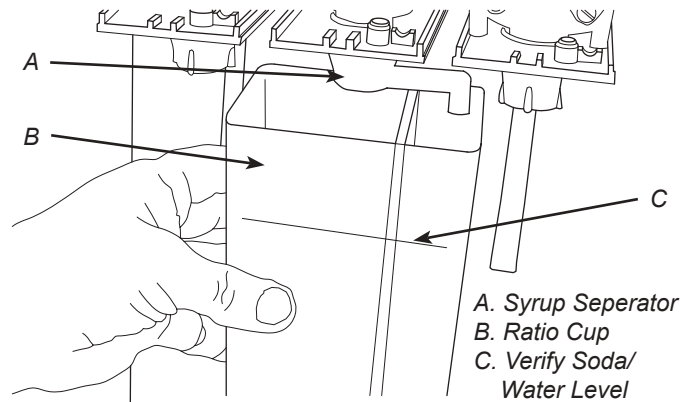

9. Repeat process for each valve.

MAINTENANCE

Scheduled Maintenance

As Needed	<ul style="list-style-type: none">• Keep exterior surfaces of dispenser (include drip tray and cup rest) clean using a clean, damp cloth.
Daily	<ul style="list-style-type: none">• Remove each nozzle and diffuser from each valve and rinse well in warm water. DO NOT use soap or detergent. This will cause foaming and off taste in finished product.• Remove cup rest and wash in warm soapy water.• Pour warm soapy water into the drip tray and wipe with a clean cloth.• With a clean cloth and warm water, wipe off all of the unit's exterior surfaces. DO NOT USE ABRASIVE SOAPS OR STRONG DETERGENTS.• Replace the cup rest and nozzles.
Weekly	<ul style="list-style-type: none">• Taste each product for off tastes.• Remove cup rest and splash plate to view water level tube indicator. Replenish as required, and replace the cup rest and splash plate.
Monthly	<ul style="list-style-type: none">• Unplug the dispenser from the power source.• Remove the bonnet and clean the dirt from the condenser using a soft brush.• Replace the bonnet and plug in the unit.
Every Six Months	<ul style="list-style-type: none">• Clean and sanitize the unit using the appropriate procedures outlined in the Cleaning and Sanitizing section of this manual.
Yearly	<ul style="list-style-type: none">• Clean water bath interior, including evaporator coils and refrigeration components.• Clean the entire exterior of the unit.

CLEANING AND SANITIZING

General Information

- Lancer equipment (new or reconditioned) is shipped from the factory cleaned and sanitized in accordance with NSF guidelines. The operator of the equipment must provide continuous maintenance as required by this manual and/or state and local health department guidelines to ensure proper operation and sanitation requirements are maintained.

NOTE

The cleaning procedures provided herein pertain to the Lancer equipment identified by this manual. If other equipment is being cleaned, follow the guidelines established by the manufacturer for that equipment.

- Cleaning should be accomplished only by trained personnel. Sanitary gloves are to be used during cleaning operations. Applicable safety precautions must be observed. Instruction warnings on the product being used must be followed.

⚠ ATTENTION

- Use sanitary gloves when cleaning the unit and observe all applicable safety precautions.
- **DO NOT** use a water jet to clean or sanitize the unit.
- **DO NOT** disconnect water lines when cleaning and sanitizing syrup lines, to avoid contamination.
- **DO NOT** use strong bleaches or detergents; These can discolor and corrode various materials.
- **DO NOT** use metal scrapers, sharp objects, steel wool, scouring pads, abrasives, or solvents on the dispenser.
- **DO NOT** use hot water above 140° F (60° C). This can damage the dispenser.
- **DO NOT** spill sanitizing solution on any circuit boards. Insure all sanitizing solution is removed from the system.

Cleaning and Sanitizing Solutions

Cleaning Solution

Mix a mild, non-abrasive detergent (e.g. Sodium Laureth Sulfate, dish soap) with clean, potable water at a temperature of 90°F to 110°F (32°C to 43°C). The mixture ratio is one ounce of cleaner to two gallons of water. Prepare a minimum of five gallons of cleaning solution. Do not use abrasive cleaners or solvents because they can cause permanent damage to the unit. Ensure rinsing is thorough, using clean, potable water at a temperature of 90°F to 110°F. Extended lengths of product lines may require additional cleaning solution.

Cleaning and Sanitizing Syrup Lines

1. Disconnect syrup lines from BIB's
2. Place syrup lines, with BIB connectors, in a bucket of warm water.
3. Activate each valve to fill the lines with warm water and flush out syrup remaining in the lines.
4. Prepare Cleaning Solution described on previous page.
5. Place syrup lines, with BIB connectors, into cleaning solution.
6. Activate each valve until lines are filled with cleaning solution then let stand for ten (10) minutes.
7. Flush out cleaning solution from the syrup lines using clean, warm water.

Sanitizing Solution

Prepare sanitizing solutions in accordance with the manufacturer's written recommendations and safety guidelines. The solution must provide 100 parts per million (PPM) chlorine (e.g. Sodium Hypochlorite or bleach). A minimum of five gallons of sanitizing solution should be prepared. Any sanitizing solution may be used as long as it is prepared in accordance with the manufacturer's written recommendations and safety guidelines, and provides 100 parts per million (PPM) chlorine.

8. Prepare Sanitizing Solution described above.
9. Place syrup lines into sanitizing solution and activate each valve to fill lines with sanitizer. Let sit for ten (10) minutes.
10. Reconnect syrup lines to BIB's and draw drinks to flush solution from the dispenser.
11. Taste the drink to verify that there is no off-taste. If off-taste is found, flush syrup system again.

⚠ CAUTION

Following sanitization, rinse with end-use product until there is no aftertaste. Do not use a fresh water rinse. This is a NSF requirement. Residual sanitizing solution left in the system creates a health hazard.

Cleaning and Sanitizing Nozzles

1. Disconnect power, so as to not activate valve while cleaning.
2. Remove nozzle by twisting counter clockwise and pulling down.
3. Remove diffuser by pulling down.

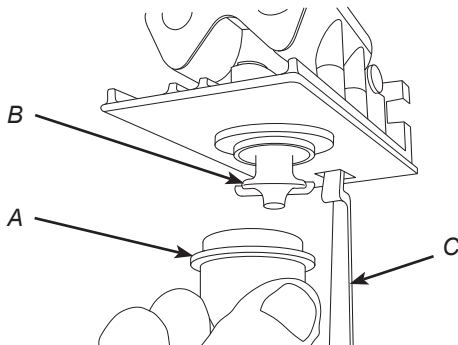

A. Nozzle
B. Diffuser
C. Soda Lever

4. Rinse nozzle and diffuser with warm water.
5. Wash nozzle and diffuser with cleaning solution then immerse in sanitizing solution and let sit for fifteen (15) minutes.
6. Set nozzle and diffuser aside and let air dry. **DO NOT** rinse with water after sanitizing.
7. Reconnect diffuser and nozzle.
8. Connect power.
9. Taste the drink to verify that there is no off-taste. If off-taste is found, flush syrup system again.

⚠ CAUTION

Following sanitization, rinse with end-use product until there is no aftertaste. Do not use a fresh water rinse. This is a NSF requirement. Residual sanitizing solution left in the system creates a health hazard.

TROUBLESHOOTING

TROUBLE	CAUSE	REMEDY
Water leakage around nozzle.	<ol style="list-style-type: none"> 1. O-ring not properly installed above diffuser 2. O-ring is damaged or missing. 	<ol style="list-style-type: none"> 1. Install or replace o-ring correctly. 2. Replace o-ring.
Leakage between upper and lower bodies.	<ol style="list-style-type: none"> 1. Gap between upper and lower valve bodies. 2. Worn or damaged paddle arm assemblies. 3. Cracked valve bodies 	<ol style="list-style-type: none"> 1. Tighten all six (6) retaining screws. 2. Replace paddle arm assemblies. 3. Replace Valve Body.
Miscellaneous leakage.	<ol style="list-style-type: none"> 1. Gap between parts. 2. Damaged or improperly installed o-rings. 	<ol style="list-style-type: none"> 1. Tighten appropriate retaining screws 2. Replace or adjust appropriate o-rings
Insufficient water flow.	<ol style="list-style-type: none"> 1. Insufficient incoming supply water pressure. 2. Shutoff on mounting block not fully open. 3. Foreign debris in water flow control. 4. Foreign debris in water pump strainer 	<ol style="list-style-type: none"> 1. Verify incoming supply water pressure is a minimum of 25 PSI (0.172 MPA). 2. Open shutoff fully. 3. Remove water flow control from upper body and clean out any foreign material to ensure smooth free spool movement. 4. Remove water pump strainer and clean.
Insufficient syrup flow.	<ol style="list-style-type: none"> 1. Insufficient CO₂ pressure to BIB pumps. 2. Out of CO₂. 3. Shutoff on mounting block not fully open. 4. Foreign debris in syrup flow control. 5. Bad syrup pump. 	<ol style="list-style-type: none"> 1. Adjust CO₂ pressure to 80 PSI (0.550 MPA) [minimum 70 PSI (0.480 MPA)] for BIB pumps. 2. Replace CO₂ tank/refill. 3. Open shutoff fully. 4. Remove syrup flow control form upper body and clean out any foreign material to ensure smooth free spool movement. 5. Replace BIB pump.
Erratic ratio.	<ol style="list-style-type: none"> 1. Incoming water and/or syrup supply not at minimum flowing pressure. 2. Foreign debris in water and/or syrup flow controls. 	<ol style="list-style-type: none"> 1. Check pressure and adjust 2. Remove flow controls from upper body and clean out any foreign material to ensure smooth free spool movement.
No product dispensed	<ol style="list-style-type: none"> 1. Water and syrup shutoffs on mounting block not fully open. 2. The key switch on an electric valve is in the OFF position. 3. Cup lever arm or ID panel actuator on electric valve is not actuating the switch. 4. Electric current not reaching valve. 5. Improper or inadequate water or syrup supply. 6. Transformer Failure 7. Bad valve solenoid(s) 	<ol style="list-style-type: none"> 1. Open shutoff fully. 2. Turn key switch to ON position. 3. Repair 4. Check electric current supplied to valve. If current is adequate, check solenoid coil and switch, and replace if necessary. 5. Remove valve from mounting block and open shutoffs slightly and check water and syrup flow. If no flow, check dispenser for freeze-up or other problems 6. Reset transformer circuit breaker. If breaker trips again check for pinched wire harness at backblocks 7. Replace Solenoid(s)

TROUBLE	CAUSE	REMEDY
Water only dispensed; no syrup; or syrup only dispensed, no water	<ol style="list-style-type: none"> 1. Water or syrup shutoff on mounting block not fully open. 2. Improper or inadequate water or syrup flow. 3. BIB supply too far from dispenser. 4. CO₂ pressure too low. 5. Stalled or inoperative BIB pump 6. Kinked line. 	<ol style="list-style-type: none"> 1. Open shutoff fully. 2. Remove valve from mounting block, open shutoffs slightly and check water and syrup flow. If no flow, check dispenser for freeze-up or other problems. Ensure BIB connection is engaged. 3. Check that BIB supply is within six (6) feet of the dispenser. 4. Check the CO₂ pressure to the pump manifold to ensure it is between 70 and 80 PSI (0.483 and 0.552 MPA). 5. Check CO₂ pressure and/or replace pump. 6. Remove kink or replace line.
No water just syrup, (Ice bank grew to water inlet line to carbonator tank.)	<ol style="list-style-type: none"> 1. Low water bath level. 2. Unit not level. 3. Syrup in water bath. 4. Water cage is out of position. 5. Refrigerant leak. 6. Check water supply. 7. Carbonator timed out. 8. PCB malfunctioning. 	<ol style="list-style-type: none"> 1. Add water until it flows from overflow tube. 2. Level unit and add water. 3. Melt ice bank. Remove all water. Refill. Locate possible syrup leak area and repair. 4. Reposition water cage. 5. Find leak and recharge unit. (If unit is not frozen.) 6. Turn water ON and shut unit OFF, 7. Turn unit OFF then ON to reset 8. See page 18.
Valve will not shut off.	<ol style="list-style-type: none"> 1. Cup lever may be sticking or binding. 2. Switch not actuating freely. 3. Solenoid armature not returning to bottom position. 	<ol style="list-style-type: none"> 1. Correct or replace lever. 2. Check switch for free actuation. 3. Replace defective armature or spring.
Syrup only dispensed. No water, but CO ₂ gas dispensed with syrup.	<ol style="list-style-type: none"> 1. Improper water flow to dispenser. 2. Carbonator pump motor has timed out. 3. Liquid level probe not connected properly to PCB. 4. Faulty PCB assembly. 5. Faulty liquid level probe. 6. Water bath frozen. 7. Water line frozen. 	<ol style="list-style-type: none"> 1. Check for water flow to dispenser (see Insufficient Water Flow on previous page). 2. Reset by turning the unit OFF and then ON (by using the ON/OFF switch on top of the unit or unplugging unit momentarily). 3. Check connections of liquid level probe to PCB assembly. 4. Replace PCB assembly. 5. Replace liquid level probe. 6. Thaw water bath and repair faulty component. (See refrigeration related symptoms.) 7. Refer to "Compressor starts and continues to run until freeze and will not cut off" in Troubleshooting.

TROUBLE	CAUSE	REMEDY
Excessive foaming.	<ol style="list-style-type: none"> 1. Incoming water or syrup temperature too high. 2. CO₂ pressure too high. 3. Water flow rate too high. 4. Nozzle and diffuser not installed. 5. Nozzle and diffuser not clean. 6. Air in BIB lines. 7. Poor quality ice. 8. High beverage temperature. 	<ol style="list-style-type: none"> 1. Correct prior to dispenser. Consider larger dispenser or pre-cooler. 2. Adjust CO₂ pressure downward, but not less than 70 PSI (0.483 MPA). 3. Re-adjust and reset ratio. Refer to "Adjust Water Flow Rate & Syrup/Water Ratio" Section on page 12. 4. Remove and reinstall properly. 5. Remove and clean. 6. Bleed air from BIB lines. 7. Check quality of ice used in drink. 8. Check refrigeration system.
Water continually overflows from water bath into drip tray.	<ol style="list-style-type: none"> 1. Loose water connection(s). 2. Flare seal washer leaks. 3. Faulty water coil. 	<ol style="list-style-type: none"> 1. Tighten water connections. 2. Replace flare seal washer. 3. Replace water coil.
Compressor starts and continues to run until freeze and will not cut off.	<ol style="list-style-type: none"> 1. PCB malfunctioning or faulty ice bank probe. 2. Ice bank probe positioned improperly. 3. Ice bank probe shorted to ground. 	<ol style="list-style-type: none"> 1. See page 18. 2. Check positioning of ice bank probe, and replace if needed. 3. Replace ice bank probe.
Warm drinks.	<ol style="list-style-type: none"> 1. Restricted airflow. 2. Dispenser connected to hot water supply. 3. Refrigeration system not running. 4. Refrigerant leak. 5. Condenser fan motor not working. 6. Dirty condenser. 7. Dispenser capacity exceeded. 	<ol style="list-style-type: none"> 1. Check clearances around sides, top, and inlet of unit. Remove objects blocking airflow through grill. 2. Switch to cold water supply. 3. Refer to page 20, the correct relay will cause compressor failure. 4. Repair and recharge. 5. Replace condenser fan motor. 6. Clean condenser. 7. Add pre-cooler or replace with larger dispenser.
Compressor does not start (no hum), gas cooler fan does not run, and no ice bank.	<ol style="list-style-type: none"> 1. There is a five (5) minute compressor and condenser fan delay. 2. Ice bank probe not completely submerged. 3. Circuit breaker or fuse tripped. 4. Inadequate Voltage 5. PCB malfunctioning 6. Incorrect Wiring 7. Faulty ice bank probe. 8. Transformer failure. 9. Ice bank probe not connected properly to PCB. 	<ol style="list-style-type: none"> 1. Allow for five (5) minute delay to lapse. 2. Fill water reservoir until water flows from overflow tube. 3. Reset breaker or replace fuse. If problem persists: Determine reason and correct or electrical circuit overloaded; switch to another circuit. 4. Measure voltage across common and run terminal on compressor. Voltage must not drop below 90% of rated voltage. 5. See page 18. 6. Refer to wiring diagram and correct. 7. Replace ice bank probe. 8. Reset transformer circuit breaker. If breaker pops again, refer to "Circuit breaker tripping" in Troubleshooting. 9. Connect ice bank probe to PCB.

TROUBLE	CAUSE	REMEDY
Compressor does not start (no hum), but gas cooler fan motor runs.	<ol style="list-style-type: none"> 1. Compressor relay capacitors or overload malfunctioning. 2. Inadequate voltage. 3. Incorrect wiring. 4. Compressor malfunctioning. 	<ol style="list-style-type: none"> 1. Replace compressor relay capacitors or overload. 2. Measure voltage across common and run terminal on compressor. Voltage must not drop below 90% of rated voltage. 3. Refer to wiring diagram and correct. 4. Have the unit repaired by a qualified service technician.
Compressor does not start but hums.	<ol style="list-style-type: none"> 1. Inadequate voltage. 2. Incorrect wiring. 3. Starting relay capacitors malfunctioning. 4. Compressor malfunctioning. 	<ol style="list-style-type: none"> 1. Measure voltage across common and run terminal on compressor. Voltage must not drop below 90% of rated voltage. 2. Refer to wiring diagram and correct. 3. Replace starting relay or capacitors. Be sure to use correct rating. Failure to use correct rating will cause compressor failure. 4. Have the unit repaired by a qualified service technician.
Compressor starts but does not switch off start winding (will run for only a few seconds before internal overload switches before internal overload switches compressor off).	<ol style="list-style-type: none"> 1. Inadequate voltage. 2. Incorrect wiring. • Starting relay malfunctioning. 	<ol style="list-style-type: none"> 1. Measure voltage across common and run terminal on compressor. Voltage must not drop below 90% of rated voltage. 2. Refer to wiring diagram and correct. 3. Replace starting relay. Be sure to use correct relay. Failure to use correct relay will cause compressor failure.
Compressor starts and runs a short time but shuts off on overload.	<ol style="list-style-type: none"> 1. Dirty condenser. 2. Insufficient or blocked air flow. 3. Inadequate voltage. 4. Incorrect wiring. 5. Defective condenser fan motor. 6. Refrigerant leak. 7. Compressor malfunctioning. 	<ol style="list-style-type: none"> 1. Clean the condenser. 2. Remove all obstruction and allow for minimum clearances of 8 inches (203 mm) over top. 3. Measure voltage across common and run terminal on compressor. Voltage must not drop below 90% of rated voltage. 4. Refer to wiring diagram and correct. 5. Have the unit repaired by a qualified service technician. 6. Have the unit repaired by a qualified service technician. 7. Have the unit repaired by a qualified service technician.
Compressor runs normally, but water line is frozen.	<ol style="list-style-type: none"> 1. Low water level in water bath. 2. Syrup in water bath. 3. Water cage is out of position. 4. Low refrigerant charge or slow refrigerant leak. 	<ol style="list-style-type: none"> 1. Add water to water bath until water runs out of overflow into drip tray. 2. Drain water from water bath and refill with clean water. 3. Reposition water cage. 4. Find and repair leak. Recharge system.
Compressor cycles on and off frequently during the initial pull-down and/or normal operations.	<ol style="list-style-type: none"> 1. PCB malfunctioning 2. Defective probe. 3. Weak overload or pressure switch. 	<ol style="list-style-type: none"> 1. See page 18. 2. Replace probe. 3. Have the unit repaired by a qualified service technician.

TROUBLE	CAUSE	REMEDY
Circuit breaker tripping.	<ol style="list-style-type: none"> 1. Valve wire harness shorted to itself or to faucet plate. 2. PCB is bad. 3. Secondary wire harness is bad. 4. Transformer failure. 	<ol style="list-style-type: none"> 1. Detect short by disconnecting input fasten to keylock and single pin connector. Restore power if breaker doesn't trip. Then valve wire harness is shorted. If OK, reconnect. 2. Detect short by disconnecting J1 connector (24 VAC input) from PCB. Restore power, if breaker doesn't trip. Then replace PCB. If breaker does trip, then PCB is OK. Reconnect J1 connector. 3. If it does not trip, locate short in secondary harness between transformer, PCB, and valve wire harness. 4. Detect short by disconnecting both transformerfastons and restore power. If breaker does trip, replace transformer.
BIB pump does not operate when dispensing valve opened.	<ol style="list-style-type: none"> 1. A. Out of CO₂, CO₂ not turned on, or low CO₂ pressure. 2. Out of syrup. 3. BIB connector not tight. 4. Kinks in syrup or gas lines. 5. Bad BIB Pumps. 	<ol style="list-style-type: none"> 1. Replace CO₂ supply, turn on CO₂ supply, or adjust CO₂ pressure to 70-80 PSI (0.483-0.552 MPA) 2. Replace syrup supply. 3. Fasten connector tightly. 4. Straighten or replace lines. 5. Replace BIB pump.
BIB pump operated, but no flow.	<ol style="list-style-type: none"> 1. Leak in syrup inlet or outlet line. 2. Defective BIB pump check valve. 	<ol style="list-style-type: none"> 1. Replace line. 2. Replace BIB pump
BIB pump continues to operate when bag is empty.	<ol style="list-style-type: none"> 1. Leak in suction line. 2. Leaking o-ring on pump inlet fitting. 	<ol style="list-style-type: none"> 1. Replace line. 2. Replace o-ring.
BIB pump fails to restart after bag replacement.	<ol style="list-style-type: none"> 1. BIB connector not on tight. 2. BIB connector is stopped up. 3. Kinks in syrup line 4. Bad BIB Pumps. 	<ol style="list-style-type: none"> 1. Tighten BIB connector. 2. Clean out or replace BIB connector. 3. Straighten or replace line. 4. Replace BIB pump.
BIB pump fails to restart when dispensing valve is closed.	<ol style="list-style-type: none"> 1. Leak in discharge line or fittings. 2. Empty BIB. 3. Air leak on inlet line or bag connector. 	<ol style="list-style-type: none"> 1. Repair or replace discharge 2. Replace BIB. 3. Repair or replace.
No product out light.	<ol style="list-style-type: none"> 1. Burned-out lamp 2. Faulty wiring or pressure switch in product line. 	<ol style="list-style-type: none"> 1. Replace lamp. 2. Repair or replace.
Low or no carbonation.	<ol style="list-style-type: none"> 1. Low or no CO₂. 2. Excessive water pressure. 3. Worn or defective carbonator pump. 4. PCB malfunctioning. 	<ol style="list-style-type: none"> 1. Check CO₂ supply. Adjust CO₂ pressure to 70 PSI (0.483 MPA). 2. Water regulator should be set at 50 PSI (0.345 MPA) 3. Replace carbonator pump. 4. See page 18.

THE ELECTRONIC ICE BANK CONTROL (EIBC)

Checking the Normal PCB Operation

⚠ WARNING

Terminal block has AC line voltage and should be covered with tape. Tape should cover bare electrical connections to prevent electrical shock.

1. Turn power OFF or insure that power has been disconnected from dispenser
2. Check condition of 0.5 amp fuse at location shown in diagram to the right. If fuse is blown, trace cause of short in valve wire harness and associated 24 VAC lines and replace fuse. If fuse is good, continue with next step.
3. Disconnect leads from the terminal block that connect to the PCB, noting their specific location for reconnection.
4. Disconnect both the Ice Bank probe (J2) and the Carbonator probe (J3) (if equipped) connections from board.
5. Use a short copper wire, paper clip, or other means to short the Ice Bank probe terminals (J2) on the PCB by touching all three (3) pins together.
6. Set Ohm test meter to measure continuity.
7. Reconnect power or turn dispenser ON.
8. Observe time and check continuity of the PCB screw lug connections:
 - Terminal 3 to 4 (Carbonator): During the first 2.5 to 3.5 minutes there should be continuity. After 2.5 to 3.5 minutes, there should be NO continuity.
 - Terminal 2 to 1 (Compressor): During first 4 to 6 minutes, there should be NO continuity. After 4 to 6 minutes, there should be continuity. There should be NO continuity from 2 to 1.
 - You should be able to hear a “click” sound of the relay closing when the time delay ends.
9. Turn electrical power OFF for 15 seconds and then back ON again to reset Carbonator timer. Again, measure continuity of the PCB screw lug connections
 - Terminal 3 to 4: There should be continuity. Use a short copper wire, paper clip, or other means to short the Carbonator probe terminals (J3) on the PCB by touching all three (3) pins together. This should be done before the 2.5 to 3.5 minute time limit has elapsed. Measure the continuity again between Terminal 3 to 4: There should be **NO** continuity.
10. If all the above work as noted, then the board is functioning properly. Remove tape and reconnect board. If any non-conformities are found, the PCB must be replaced (PN 52-1423/01).

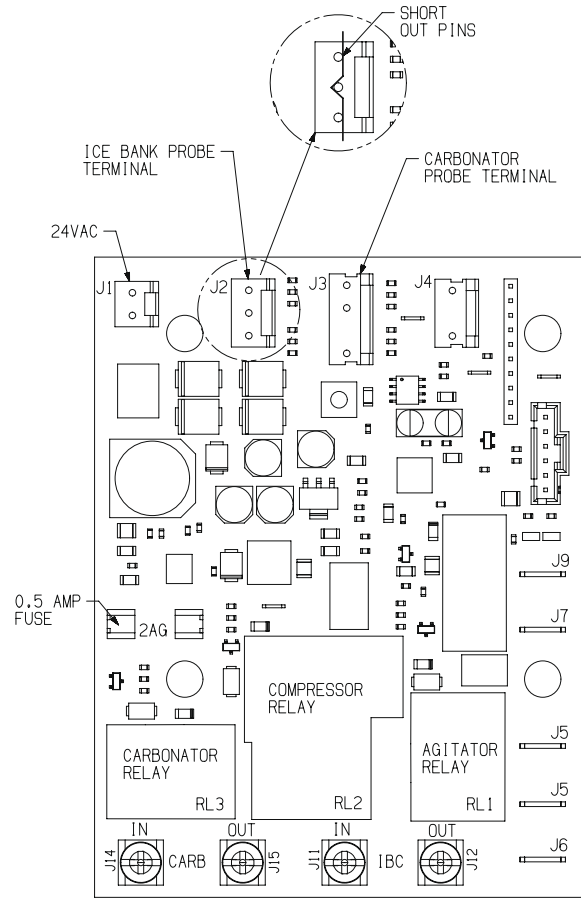

ILLUSTRATIONS AND PART LISTINGS

Installation Kits and Optional Accessories

<u>Part No.</u>	<u>Description</u>
82-1796	BIB Installation Kit - for 3/8 inch Syrup Inlets
82-0221-06	FIGAL Installation Kit - 6 Valve - For 1/4 Inch Syrup Inlets
82-0221-08	FIGAL Installation Kit - 8 Valve - For 1/4 Inch Syrup Inlets
82-2613-06	FIGAL Installation Kit - 6 Valve - For 3/8 Inch Syrup Inlets
82-2613-08	FIGAL Installation Kit - 8 Valve - For 3/8 Inch Syrup Inlets
82-0344	Leg Kit
82-2139	EIBC Retrofit Kit - International Only
82-2572 ELS	Marquee Kit - Graphics Included
82-1802	24VAC Lighted Marquee (Graphics Ordered Separately)

Marquee Graphics for Part Number 82-1802 Only:

<u>Part No.</u>	<u>Description</u>
06-1790	Coca-Cola Dynamic Ribbon, Screened
06-1789	Coca-Cola Three Cup, "Taste Real Refreshment", Duratrans

Dispenser Disposal

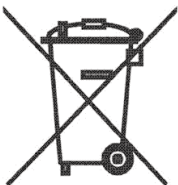

To prevent possible harm to the environment from improper disposal, recycle the unit by locating an authorized recycler or contact the retailer where the product was purchased. Comply with local regulations regarding disposal of the refrigerant and insulation.

Cabinet Assembly

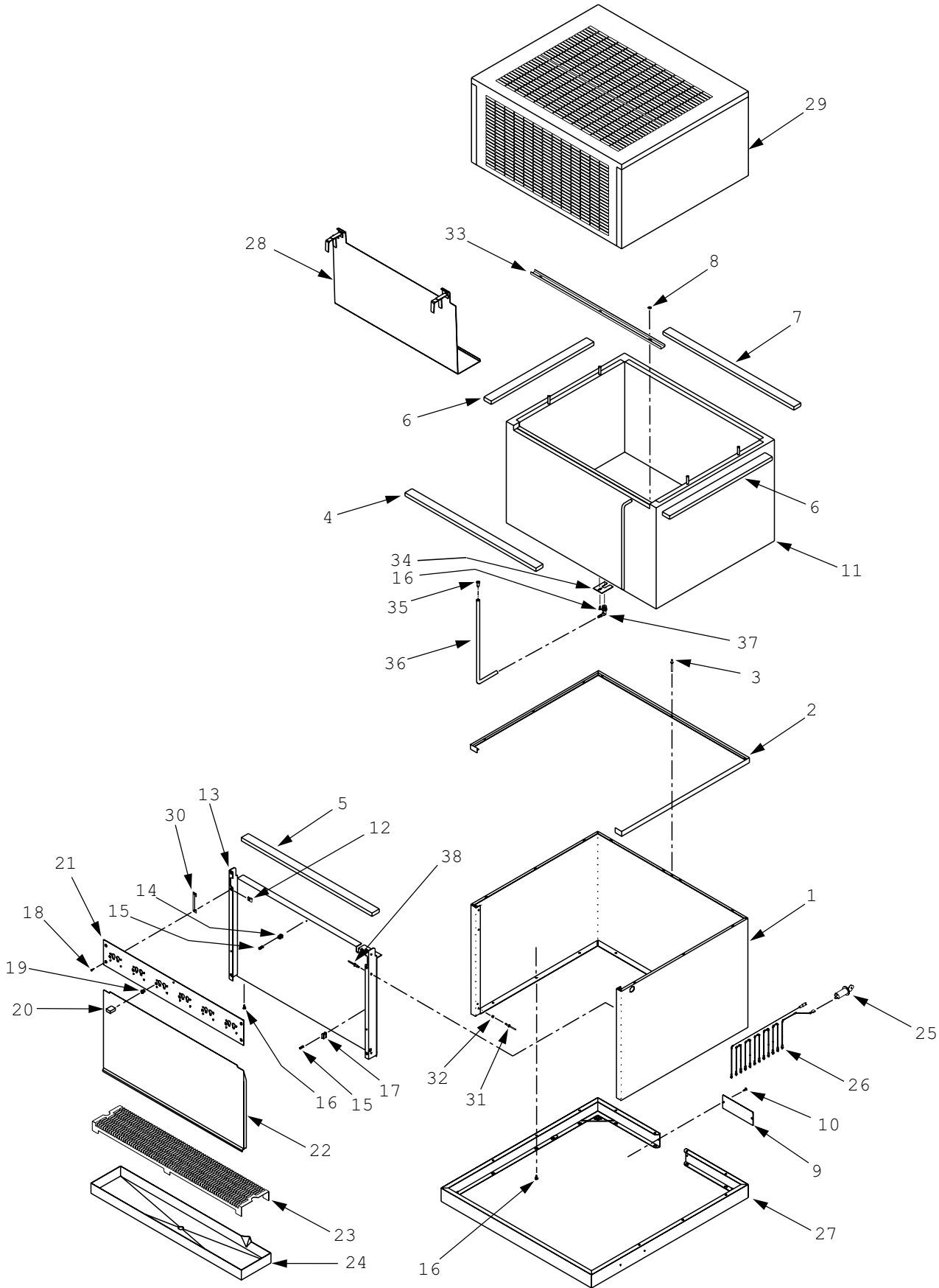

<u>Item</u>	<u>Part No.</u>	<u>Description</u>			
1	30-0643/01	Wrapper, External	22	30-6640	Splash Plate
2	51-0547	Trim, Gray	23	30-0535	Cup Rest
3	04-0067	Rivet	24	23-0306	Drip Tray
4	50-0175	Insulation, 1/2 inch	25	12-0097	Key Lock Switch
5	50-0180	Insulation, 1/2 inch	26	52-0893/01	Harness Assy, 8-Valve
6	50-0102	Insulation, 1/8 inch	--	52-1214	Harness Assy, 6-Valve
7	50-0184	Insulation, 1/8 inch	27	51-0582	Base Assy
8	04-0082	Nut, Hex, 10 - 24, SS	28	82-1120	Insulator Plate Assy
9	30-0612	Back Plate	29	23-0443/02	Bonnet Assy (Specify Graphics)
10	04-0477	Screw, 8 - 32 x 0.375 inch	30	30-5314	Shim Plate
11	42-0013	Tank, Foamed	31	04-1012	Rivet, Splash Plate Spacer
12	04-0074	Nut, Clip, 10 - 24	32	01-1705	Spacer, Splash Plate
13	30-0649/02	Front Support Plate	33	30-5599/02	Retainer, Cage, 2500
14	03-0036	Clip, Drain Tube	34	30-5143	Clip, Drain
15	04-0077	Screw, #4 x 1/4 inch	35	01-0450	Tube Support
16	04-0061	Screw, #8 x 1/2 inch	36	08-0190	Drain Tube
17	03-0115	Clip, Overflow Tube	37	01-1483	Elbow Drain Assy
18	04-0443	Screw, 10 - 24 x 0.375	38	04-0072	Rivet
19	13-0005	Bushing, Strain Relief	NOTE: Cage Assembly Part Numbers are:		
20	11-0015	Connector Housing	-	23-1232/01	6-Valve, 3-2-1 Manifold, 3/8 inch Syrup Inlets
21	23-0391	Faucet Plate, 8-Valve	-	23-1236/01	8-Valve, 3-1-1-3 Manifold, 3/8 inch Syrup Inlets
--	23-0605	Faucet Plate, 6-Valve	-	23-0919	4-Circuit Chiller
--	30-6702	Faucet Plate, 6-Valve, Premix	-	23-0798/01	9-Circuit Chiller
--	30-6703	Faucet Plate Stiffener, 6-Valve, Premix	-	23-1103	6-Valve Premix

Refrigeration Deck Assembly, R-134A, with Lancer Electronic Ice Bank Control (EIBC) PN: 82-2669; USA only (Manufactured from 01/1999)

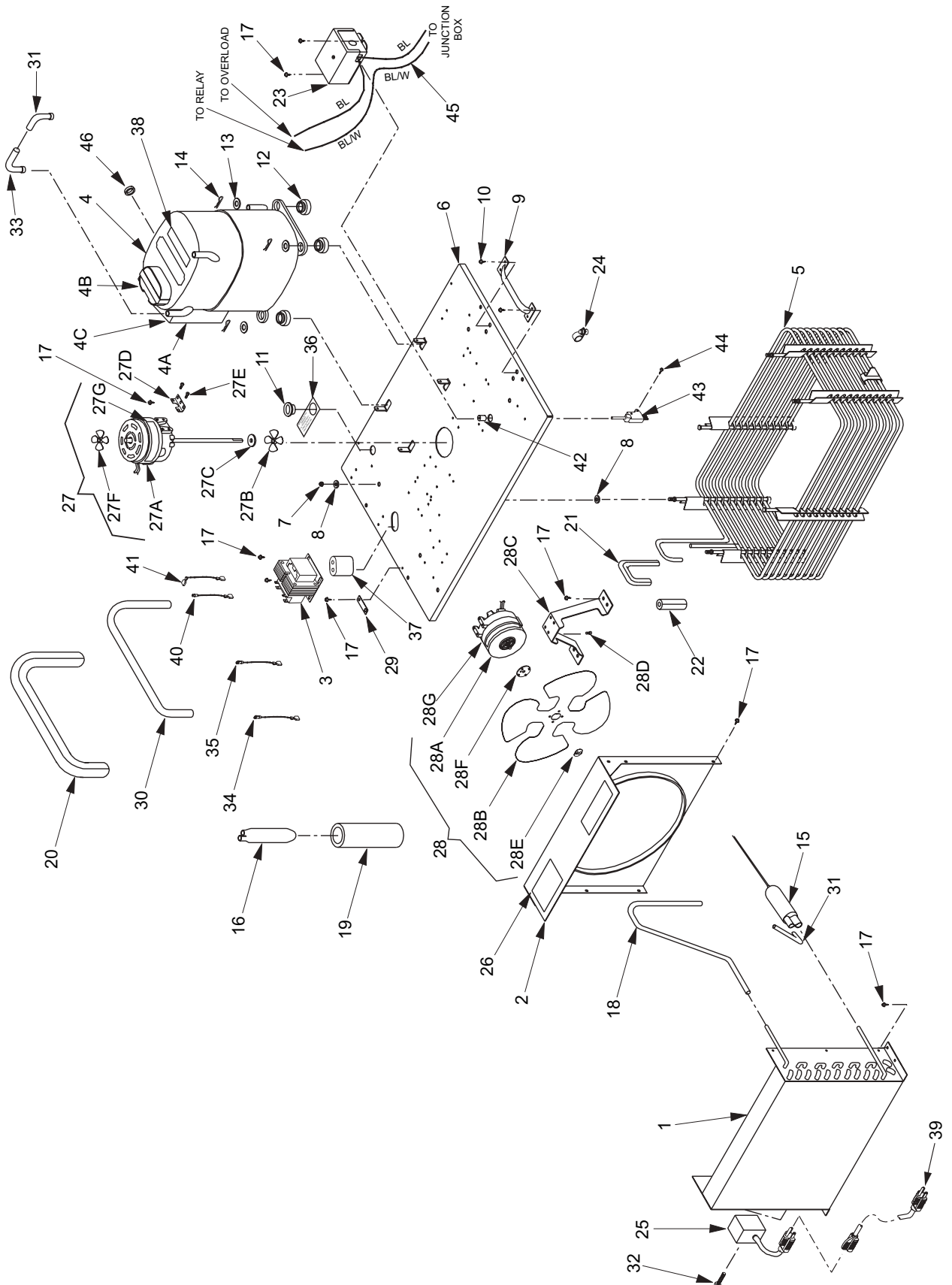

Item	Part No.	Description		
1	23-0986	Condenser	27B 05-0502	Propeller, Agitator
2	51-0349	Shroud Assy	27C 02-0032	Washer, Rubber, 1.000 OD
3	25-0047	Transformer, 115V/60Hz	27D 30-5113/01	Agitator Motor Bracket
4	83-0101	Compressor, 115V/60Hz	27E 04-0059	Screw, 8 - 36 x 0.375
4A	12-0233	Start Capacitor, 115V/60Hz	27F 05-0424/01	Agitator Fan
4B	12-0227	Overload, 115V/60 Hz	27G 06-0633	Label, 115V/60Hz, 25W
4C	12-0232	Relay, 115V/60Hz	28 52-0740	Fan Motor Assy, 115V/60Hz
-	-----	Refrigerant, R134A Only, 15.5 Oz	28A 91-0017	Fan Motor, 115V/60Hz
5	23-1205	Evaporator Coil Assy	28B 07-0257	Fan Blade
6	82-0675	Compressor Deck Assy	28C 30-0043	Bracket, Fan Motor
7	04-0032	Nut, 1/4 - 20	28D 04-0059	Screw, 8 - 36 x 0.375
8	04-0063	Washer, 0.260 ID x 0.687 OD, SS	28E 04-0060	Nut, Fan Blade
9	07-0268	Deck Handle	28F 02-0413	Silencer, Fan Blade
10	04-0260	Screw, 10 - 16 x 0.625	28G 06-0667	Label, 115V/60Hz, 35W
11	04-0538	Fill Hole Plug	29 11-0118	Connector, Ground
12	02-0114	Grommet, Compressor	30 47-2033/01	Tube, Suction
13	04-0537	Washer, Compressor	31 47-0344	Tube, Process
14	03-0150	Retainer Clip, Compressor	32 04-0070	Screw, 10 - 24 x 1.312
15	23-0999	Dryer/Capillary Tube Assy	33 01-1713	Reducer, Fitting, Elbow
16	51-5400	Accumulator	34 52-0878	Wire, Transformer Lead, Primary
17	04-0504	Screw, 8 - 18 x 0.375	35 52-0879	Wire, Transformer Lead, Primary
18	47-2064	Tube, High Side	36 06-0856/01	Fill Hole Label
19	50-0105	Accumulator Insulator Boot	37 02-0040	Seal, Extrusion
20	50-0106	Insulation, Low Side	38 06-0663	Label, 115V/60Hz, 3/4 HP
21	50-0107	Insulation, Evaporator Outlet	39 21-0085	Power Cord, USA
22	50-0108	Insulation, Evaporator Inlet	40 52-1504	Wire Assy, Secondary, White
23	52-1882	Electronic Ice Bank Control (EIBC)	41 52-1505	Wire Assy, Secondary, Black
24	03-0049	Cord Clip	42 02-0041	Seal
25	52-0100	Power, Junction Assy	43 52-1897	Probe Assy
26	06-0031/01	Wiring Diagram, 2500	44 04-0394	Screw, 6 - 32 x 0.500, PHP, SS
27	52-1259	Agitator Motor Assy, 115V/60Hz	45 52-1827	Harness Assy, EIBC
27A	91-0083	Motor, Agitator, 115V/60Hz	46 13-0059	Bushing, Heyco

Refrigeration Deck Assembly, R-134A, with Lancer Electronic Ice Bank Control (EIBC) PN 82-2049E, 230V/50Hz; PN 82-2103E, 115V/60Hz; PN 82-2098E, 240V/60Hz; International only

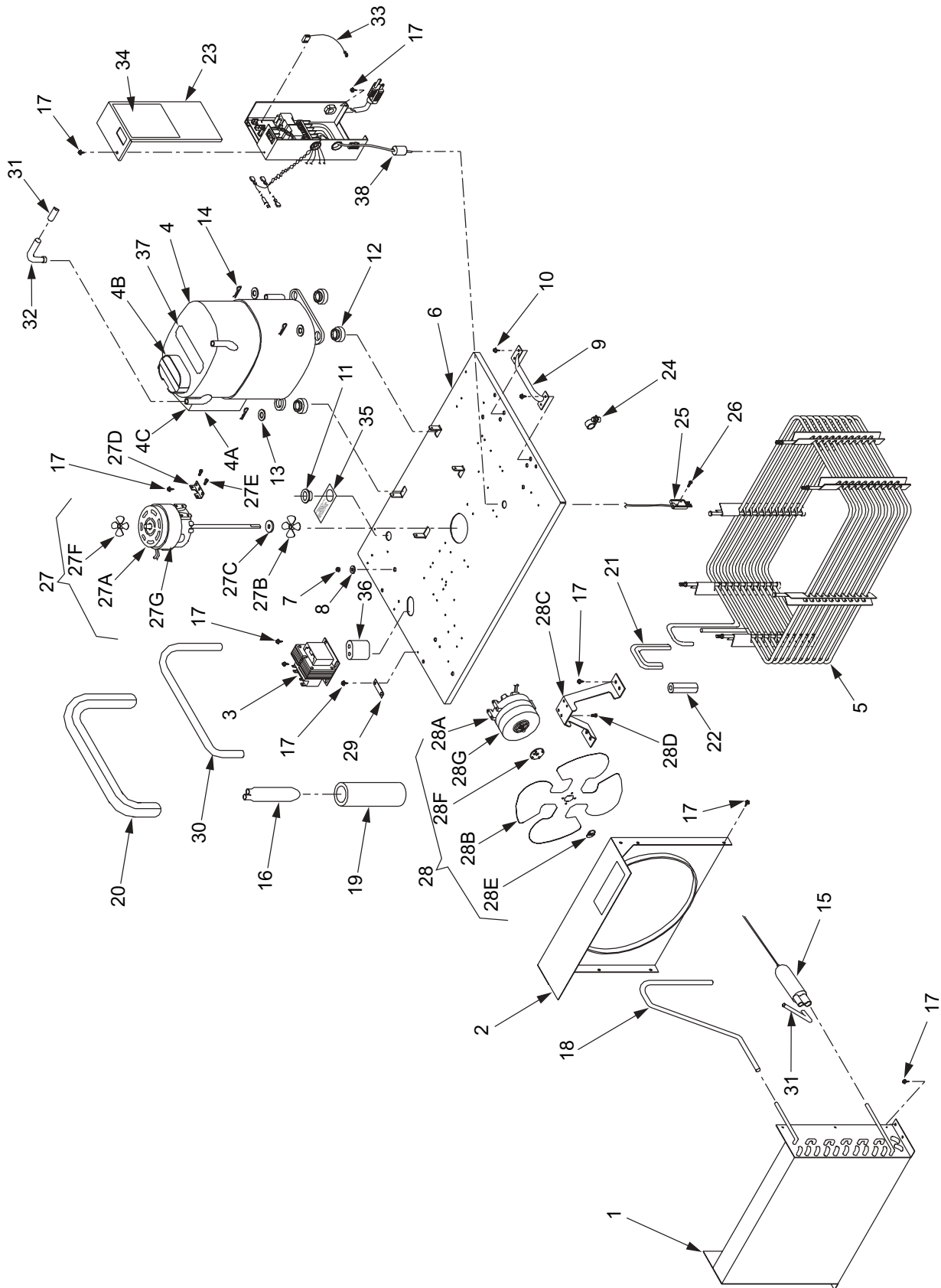

Item	Part No.	Description			
1	23-0986	Condenser	26	04-0394	Screw, 6 -32 x 0.500
2	51-0349	Shroud Assy	27	52-1259	Agitator Motor Assy, 115V/60Hz
3	25-0047	Transformer, 115V/60Hz	-	52-1118	Agitator Motor Assy, 220-240V/ 50-60Hz
-	25-0048	Transformer, 230V/50-60Hz			
4	83-0101	Compressor, 115V/60Hz	27A	91-0083	Motor, Agitator, 115V/60Hz
-	83-0102	Compressor, 230V/50Hz	-	91-0086	Motor, Agitator, 230V/50Hz and 240V/60Hz
-	83-0103	Compressor, 240V/60Hz			
4A	12-0233	Start Capacitor, 115V/60Hz	27B	05-0502	Propeller, Agitator
-	12-0235	Start Capacitor, 230V/50Hz	27C	02-0032	Washer, Rubber, 1.000 OD
-	12-0246	Start Capacitor, 240V/60Hz	27D	30-5113/01	Agitator Motor Bracket
4B	12-0227	Overload, 115V/60Hz	27E	04-0059	Screw, 8 - 36 x 0.375
-	12-0045	Overload, 230V/50Hz	27F	05-0424/01	Agitator Fan
-	12-0043	Overload, 240V/60Hz	27G	06-0633	Label, 115V/60Hz, 25W
4C	12-0232	Relay, 115V/60Hz	-	06-0634	Label, 230V/50-60Hz, 25W
-	12-0236	Relay, 230V/50Hz	28	52-0740	Fan Motor Assy, 115V/60Hz
-	12-0247	Relay, 240V/60Hz	-	52-0741	Fan Motor Assy, 240V/60Hz
-	-----	Refrigerant, R134A Only; 115V/60Hz and 240V/60Hz, 15.5oz; 230V/50Hz, 15.75 Oz	-	52-0742	Fan Motor Assy, 230V/50Hz
5	23-1205	Evaporator Coil Assy	28A	91-0017	Fan Motor, 115V/60Hz
6	82-0675	Compressor Deck Assy	-	91-0018	Fan Motor, 230V/50Hz
7	04-0032	Nut, 1/4 - 20	-	91-0019	Fan Motor, 240V/60Hz
8	04-0063	Washer, 0.260 ID x 0.687 OD, SS	28B	07-0257	Fan Blade
9	07-0268	Deck Handle	28C	30-0043	Bracket, Fan Motor
10	04-0260	Screw, 10 - 16 x 0.625	28D	04-0059	Screw, 8 - 36 x 0.375
11	04-0538	Fill Hole Plug	28E	04-0060	Nut, Fan Blade
12	02-0114	Grommet, Compressor	28F	02-0413	Silencer, Fan Blade
13	04-0537	Washer, Compressor	28G	06-0667	Label, 115V/60Hz, 35W
14	03-0150	Retainer Clip, Compressor	-	06-0668	Label, 230V/50Hz, 35W
15	23-0999	Dryer/Capillary Tube Assy	-	06-0669	Label, 240V/60Hz, 35W
16	51-5400	Accumulator	29	11-0118	Connector, Ground
17	04-0504	Screw, 8 -18 x 0.375	30	47-2033/01	Tube, Suction
18	47-2064	Tube, High Side	31	47-0344	Tube, Process
19	50-0105	Accumulator Insulator Boot	32	01-1713	Reducer, Fitting, Elbow
20	50-0106	Insulation, Low Side	33	52-2027	Harness Assy, EIBC Ground
21	50-0107	Insulation, Evaporator Outlet	34	06-1542	Wiring Diagram, Label, EIBC
22	50-0108	Insulation, Evaporator Inlet	35	06-0856/01	Fill Hole Label
23	52-2026	Control Housing Assy, EIBC	36	02-0040	Seal, Extrusion
24	03-0049	Cord Clip	37	06-0663	Label, 115V/60Hz, 3/4HP
25	52-1773	Probe Assy, EIBC	-	06-0664	Label, 230V/50Hz, 3/4HP
			-	06-0665	Label, 240V/60Hz, 3/4HP
			38	02-0041	Seal

Control Housing Assembly, (EIBC) - International Only

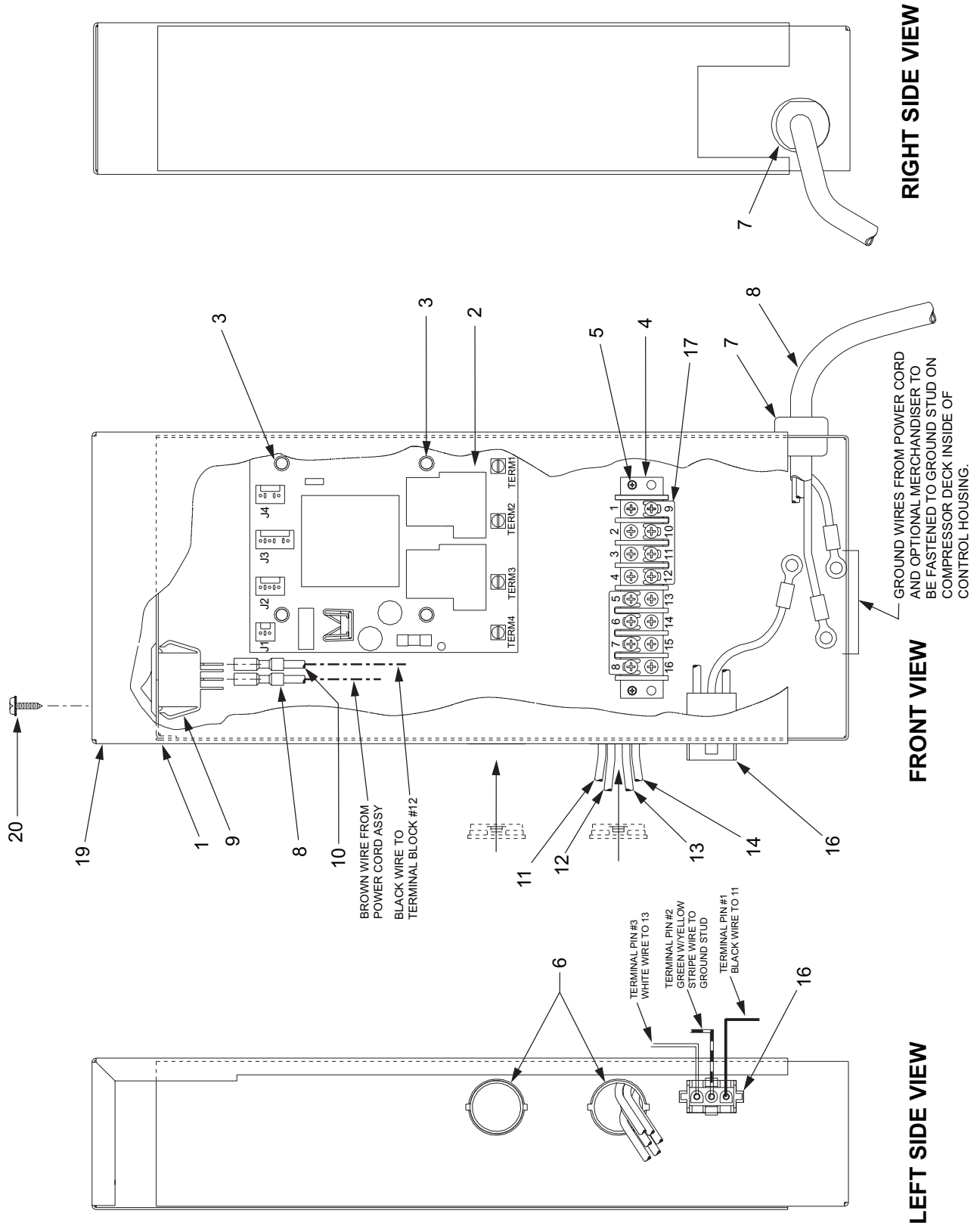

Item	Part No.	Description
1	30-7012	Housing, Control
2	52-1423	PCB Assy
3	13-0047	Stand Off
4	12-0190	Block, Terminal
5	04-0477	Screw, 8 - 32, ROLOK
6	13-0059	Bushing
7	13-0028	Strain Relief
8	52-2057	Power Cord Assy
9	-----	Not Applicable
10	-----	Not Applicable
11	52-2021	Lead Assy, Transformer, Primary, #1
12	52-2022	Lead Assy, Transformer, Primary, #2
13	52-2023	Lead Assy, Compressor, #1
14	52-2024	Lead Assy, Compressor, #2
15	52-2061	Lead Assy, EIBC
16	52-1210	Harness Assy, Optional Merch.
17	11-0186	Jumper
18	52-1058	Harness, Transformer, Secondary
19	30-7015	Cover, EIBC, Box Without Kill Switch
20	04-0504	Screw, 8 -18 x 0.375

WIRING CONNECTION CHART		
PART NO.	DESCRIPTION	TERMINAL
52-1219 with Kill Switch	Power Cord (BLU)	15
	Power Cord (GRN/YEL)	Ground Stud
	Power Cord (BRN)	Kill Switch (A-A)
52-1218 without Kill Switch	Power Cord (BLU)	15
	Power Cord (GRN/YEL)	Ground Stud
	Power Cord (BRN)	12
52-2038	Lead, Kill Switch, 14 GA (BLK)	12
52-2021	Lead, Trans, Pri #1 (BLK)	3
52-2022	Lead, Trans, Pri #2 (BLK/ WHT)	3
52-2058	Harness, Trans, Sec (BLK)	J1
	Harness, Trans, Sec (WHT)	
52-2023	Lead, Comp #1 (BLK)	Terminal 1
52-2024	Lead, Comp #2 (BLK/WHT)	6
52-1773	IBC Probe Assy	J2
52-1259	Lead, Agitator Motor (BLK)	10
52-0742	Lead, Agitator Motor (BLK-RIDGED)	14
52-1210	Harness, Optional Merchandiser (BLK)	11
	Harness, Optional Merchandiser (GRN/YEL)	Ground Stud
	Harness, Optional Merchandiser (WHT)	13
52-2061	Lead Assy, EIBC, 2500	Terminal 2 to 1

Wiring Diagram, Electronic Ice Bank Control (EIBC), USA only

IMPORTANT

WHEN STARTING UNIT OR IF CURRENT IS INTERRUPTED, THERE IS A FIVE (5) MINUTE DELAY BEFORE THE COMPRESSOR/FAN STARTS.

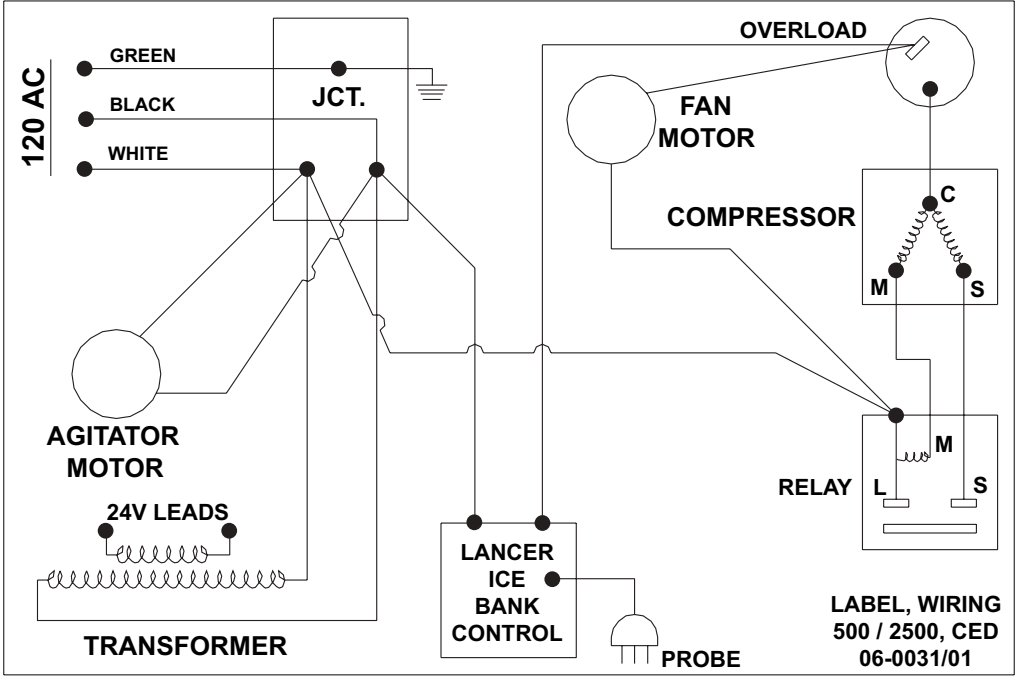

Control Housing Connections

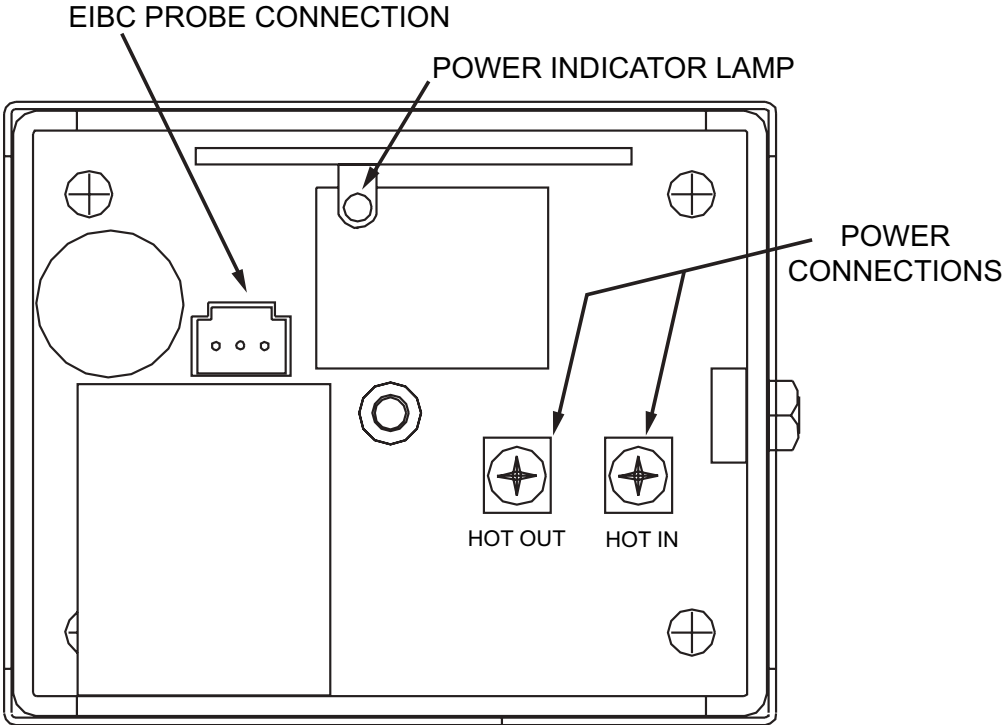

Wiring Diagram, Electronic Ice Bank Control (EIBC), International only

IMPORTANT

WHEN STARTING UNIT OR IF CURRENT IS INTERRUPTED, THERE IS A FIVE (5) MINUTE DELAY BEFORE THE COMPRESSOR/FAN STARTS.

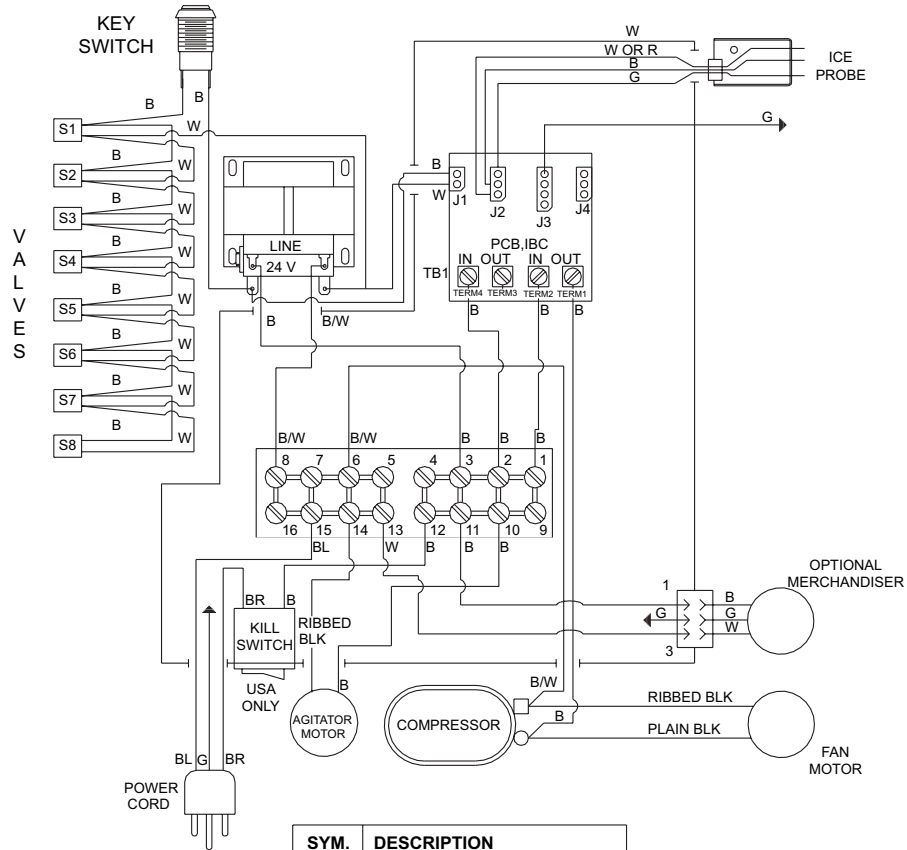

SYM.	DESCRIPTION
	CHASSIS GROUND
	CONTROL BOX
	CHAMFER PIN 1

LANCER LABEL,
WIRING DIAGRAM
06-1542

Plumbing Diagram - 8 Valve and 6 Valve

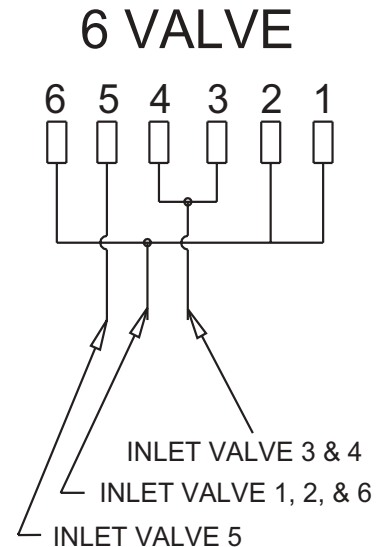
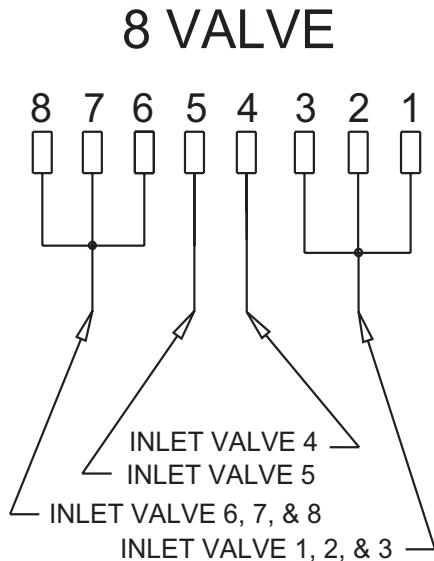

LANCER[®]

Lancer Corp.
800-729-1500
Technical Support/Warranty: 800-729-1550
custserv@lancercorp.com
lancercorp.com