

Brix Pump

The Brix pump is a proportioning device, which pumps two liquids (e.g. water and concentrate) in an exact ratio. The particular ratio is determined by the pump design, and is thereby maintained precisely, independent of system flow or pressure changes, with no need to regularly readjust brix at the dispensing valve.

The pump operates on the source pressure of one of the proportioned liquids; typically the incoming water eliminating the need for CO₂ or electric power.

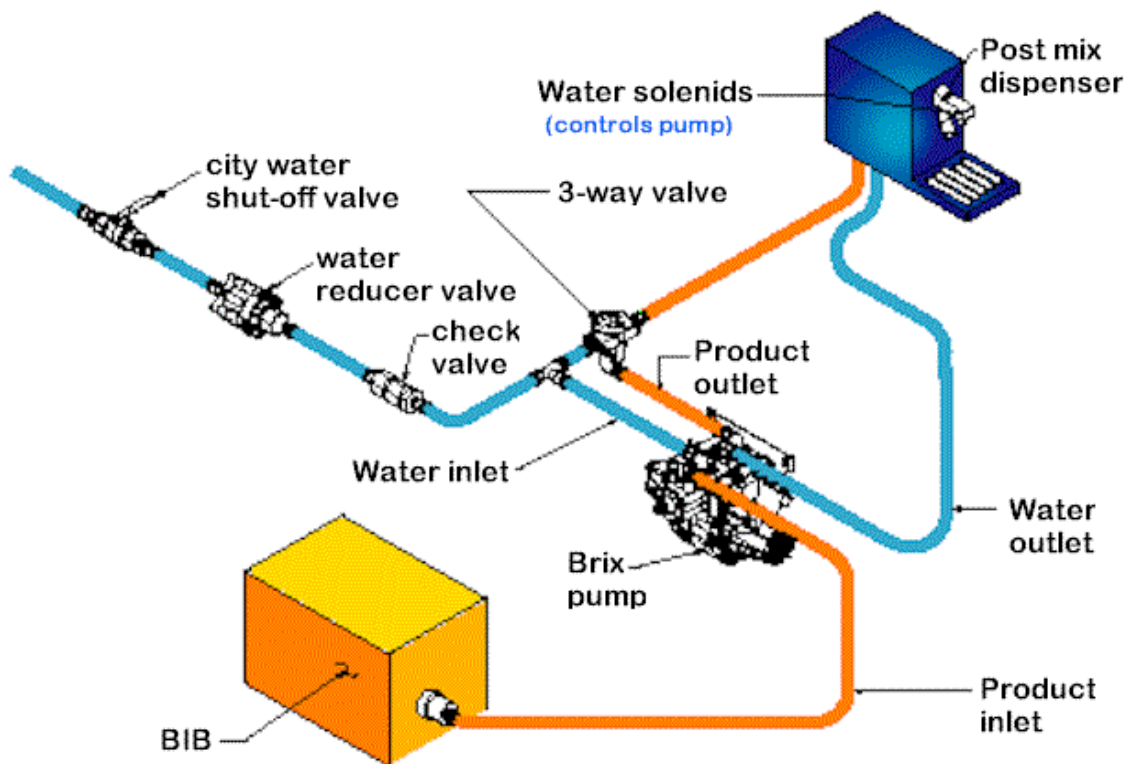

The Brix pump is designed with a vacuum shut off. The vacuum shut-off will automatically stop operation of the brix pump, when the concentrate BIB container is completely evacuated, by closing off the water inlet. When a new BIB is installed, the pump will automatically resume operation without the need to prime the system.

The Brix pump is ideally suited to premium juice applications, and incorporates a valve design suitable for use with syrups containing "stringy" pulp.



The table below shows brix pump ratios currently available. The brix pump is shipped with the 3-way sanitizing valve.

Model	Ratio	Qty./Box
94-260-01	3:1 pump	8
94-260-03	4:1 pump	8
94-260-05	5:1 pump	8
94-260-06	5.3:1 pump (6:1 APR FOR FCB)	8
94-260-07	7.7:1 pump	8
94-260-17	4.2:1 pump w/o sold out feature	8

Technical Specs

DESIGN:	Positive Displacement; Fix Ratio (non-adjustable)
POWER SOURCE:	Potable Water
MATERIALS OF CONSTRUCTION:	Acetal Copolymer, EPDM, Santoprene, Silicone, 316 Stainless Steel-FDA sanctioned, NSF listed
TEMPERATURE LIMITS:	34 - 120°F [2-45°C]
DIMENSIONS	7.6" x 5.2" x 5.7" [19.3 x 13.2 x 14.47 cm]
WEIGHT:	2.2 lbs. [1 kgs]
OPERATING PRESSURE:	50 PSI. [3.4 bar] MAX. / 25 PSI. [1.7 bar] MIN.
ACCURACY:	± 3% of available ratio
SOLD OUT:	Automatic B-I-B Vacuum Shut-off @ 18-22 in. Hg. [48-61 kPa]
AVAILABLE FITTINGS:	3/8" [10mm] Barb, Plastic 90° Std. Configuration, 1/4" [6mm] , 3/8" [10mm], and 1/2" [13mm] barb, Plastic or Stainless Steel; Straight and/or 90° configurations

[Operations Manual](#)

SHURflo

BRIX PUMP 5000-2XX-XX

Installation and Operation Instruction Manual

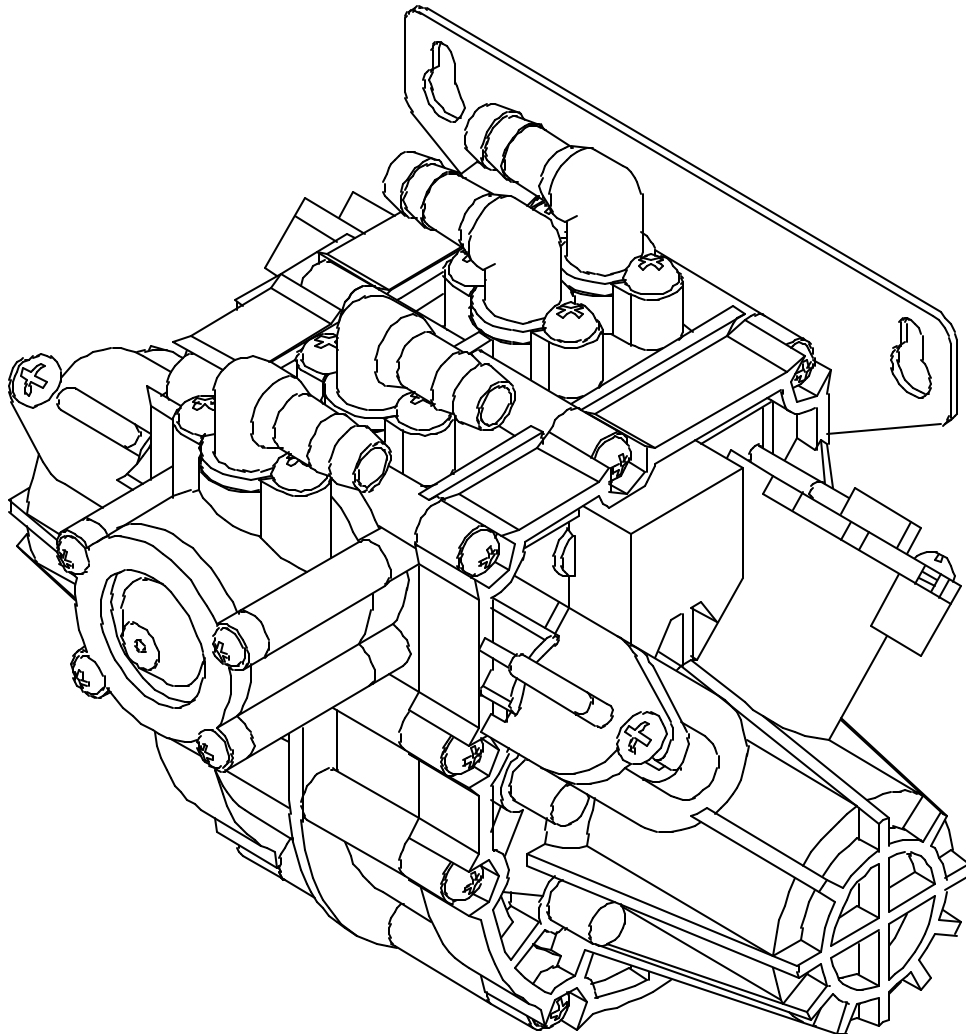

SHURflo has applied its expertise and years of experience in pump technology to provide a safe and reliable proportioning pump. Every SHURflo pump is 100% tested for proper flow, pressure, and performance before it leaves the factory. Although this tested design will provide years of trouble-free and economical operation, you should use care in installing your system.

DESCRIPTION

The SHURflo BRIX proportioning pump is driven by pressurized water, allowing the water and product to be delivered at an exact ratio. The pump operates whenever there is a differential in pressure between the inlet and outlet watersides of the pump. The design incorporates large "duck bill" style valves that easily allow concentrates with pulp or particulates to flow through. When your customers demand a quality drink, you are assured that SHURflo technology will deliver accurate repeatable brix without the need for expensive metering devices.

MODEL OPTIONS

The BRIX pump is offered in two basic configurations, with or without a vacuum shut-off. The last two numbers of the model indicate the use (-02), or deletion (-01) of the shut-off. The type of concentrate container being used determines if the shut-off should be applied.

When a Bag-in-Box (B-I-B) container is used, a vacuum shut-off is needed. The pump will automatically stop operation, when the concentrate bag is completely evacuated, by closing off the inlet water. When a new B-I-B is installed, the pump will automatically resume operation without the need to prime the system. BRIX pumps without a vacuum shut-off option should be used with rigid sided containers like tanks or jugs. Containers of this type **must** be vented.

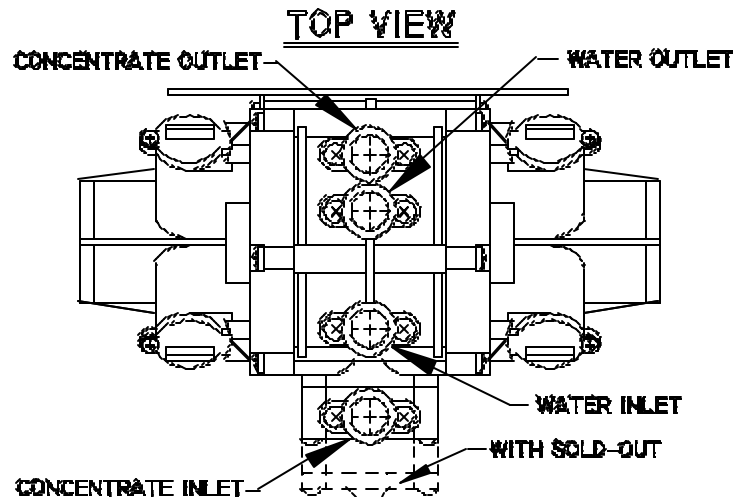

Dashed lines indicate position of vacuum shut-off when ordered.

The BRIX pump is available in exact ratios, which properly proportion various concentrate types. Pump ratios are indicated on the part number label. The ratio of a pump is preset and is not adjustable in any way.

DISPENSER CONFIGURATION

The dispenser valve is an important component to the BRIX pump system and contributes heavily to the final performance. When developing the system, the type of dispenser depends on the customers requirements, concentrate properties, backpressure created within the lines, and the dispensers ability to flow. A BRIX pump is designed to deliver to one dispenser valve at a time. If other valves are on line, it is acceptable only when a lockout device prevents simultaneous operation. Depending on the system design and the concentrate, finished drink flow rates are generally 1½ - 3 ounce [45-90 cc] per second.

POST MIX

Dispenser valves, which have separate water and concentrate lines, will typically exhibit good performance. Mixing the drink at the nozzle reduces backpressure, allowing longer outlet tubing lengths. Pump operation is controlled by opening or closing the water outlet line of the pump. The concentrate line must not be closed off while the water outlet line is open and the pump is cycling, or damage to the pump may occur. When multiple concentrates are plumbed to a post-mix dispenser, each pump's water outlet **must** have an individual line, valve to open when that flavor is selected.

"Bar Guns" (generally) are restrictive; therefore, it is recommended that special "Juice Guns" be used. Concentrate passages of standard bar guns are small and may become plugged with pulp or solids contained in some concentrates. Concentrates with pulps or solids may require sanitizing more frequently to prevent build-up in the system, causing poor performance.

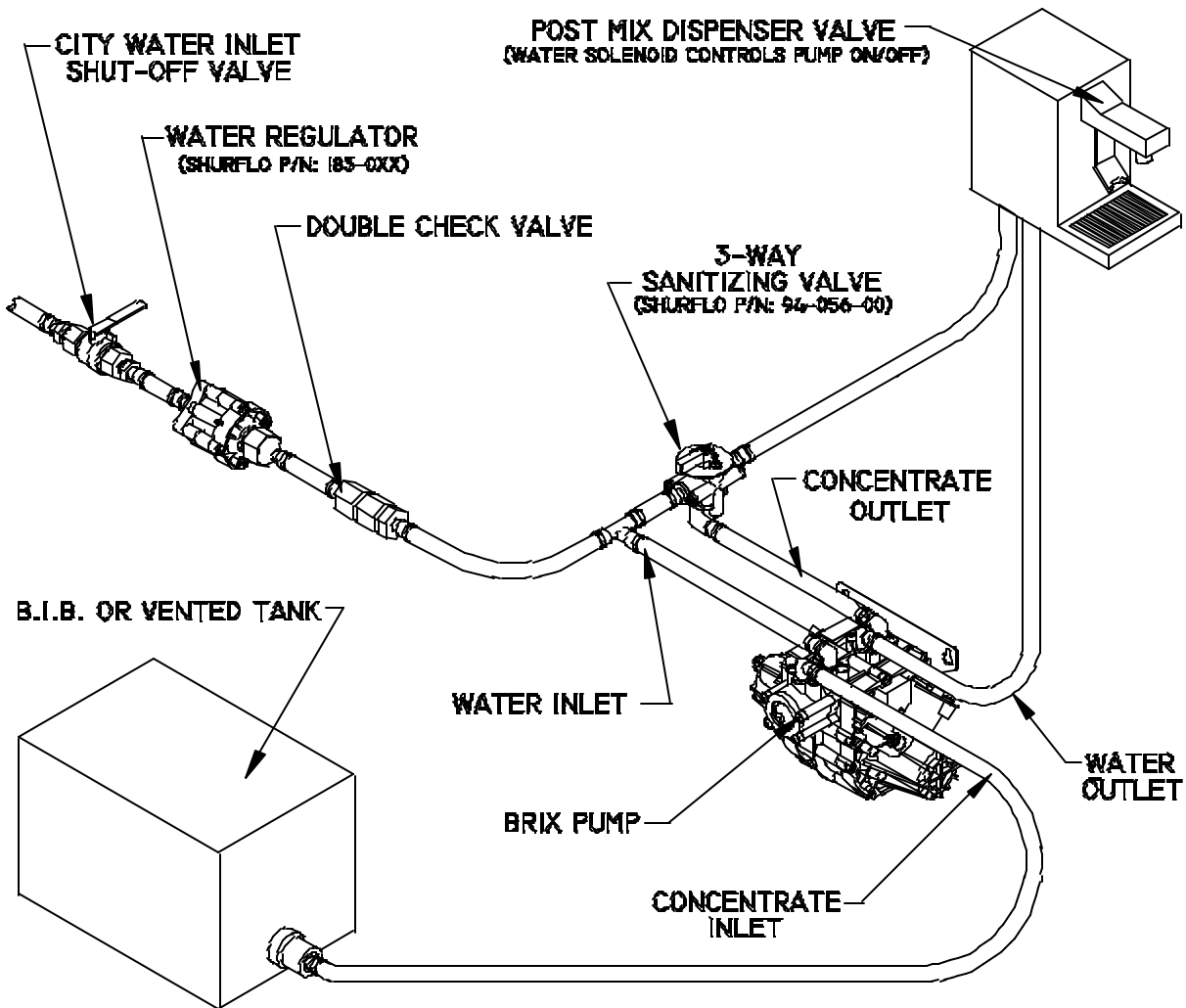

Standard post-mix system plumbing with 3-way sanitizing

TEED OUTLETS

By "teeing" the water and concentrate outlet lines together a standard beverage (non-post mix) valve can be used. A single line to the valve allows the concentrate and water to mix before being dispensed. Teed systems are commonly used with "batch mix" application such as visual units, bubblers and frozen carbonated beverage. Concentrates that do not blend properly in the line can be improved by installing a static mixing chamber in line prior to the dispenser.

The single line run lengths should be minimal to reduce backpressure. Backpressure within teed outlet line should not exceed 32 psi. [2.0 bar]. Pre-mix valves with minimal full-flow backpressure are commonly used with this type of configuration. Teed systems should have a one-way check valve plumbed after the concentrate outlet and before teeing into the water outlet line to prevent possible water back flow. Whenever the concentrate is in contact with water the possibility of spoilage is increased and sanitizing of the system may need to be more frequent.

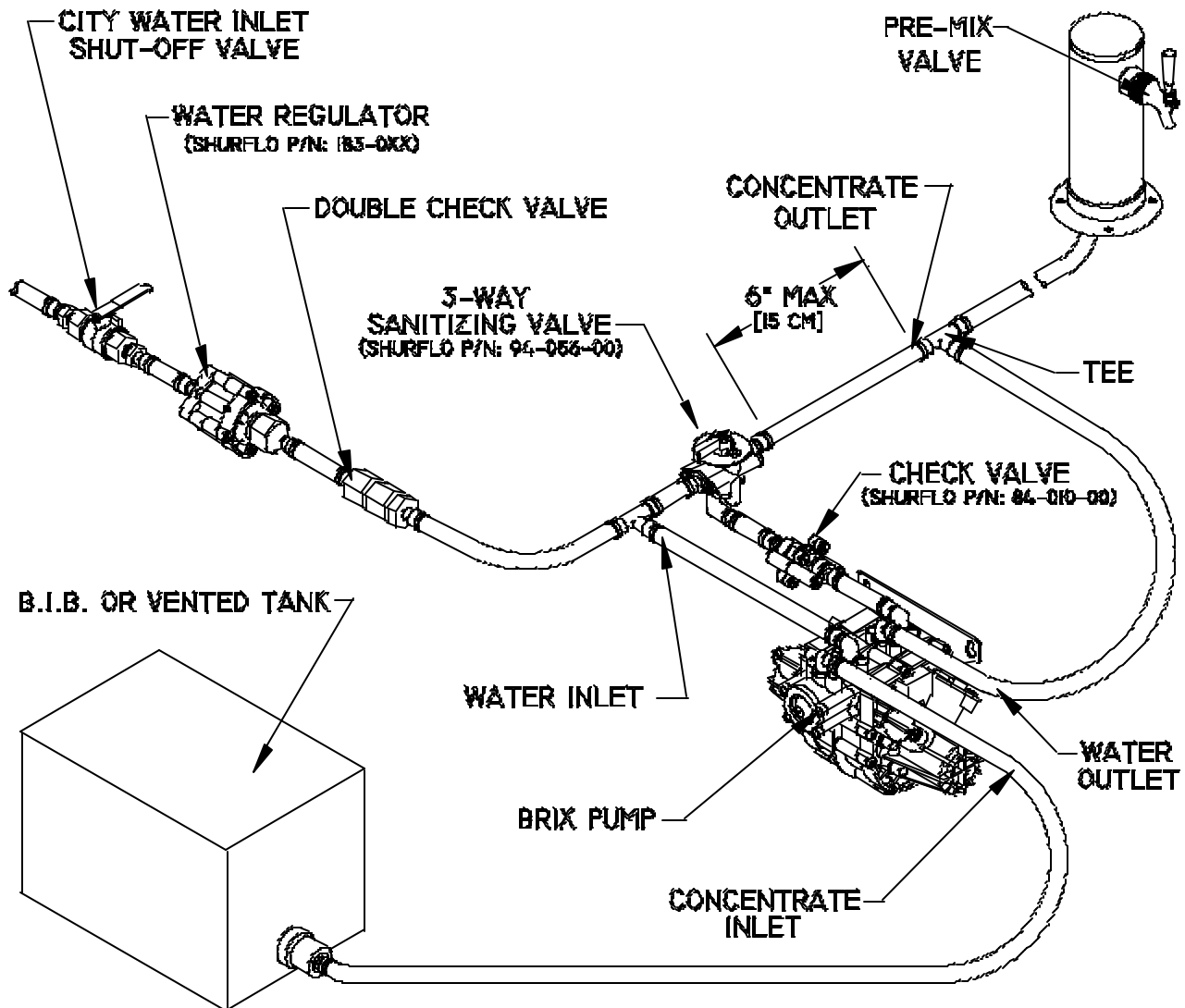

Teed outlet plumbing with 3-way sanitizing valve.

MOUNTING

Depending on constraints within a facility, the type of system and concentrate characteristics, placement of the pump is critical for each particular system installation.

The BRIX pump should be placed as close to the concentrate supply as possible, and mounted with the fittings vertical (up). Preferred mounting is slightly above or at least the same level as the container. If a pump must be mounted considerably higher, the amount of vertical lift is dependent upon concentrate viscosity (see Inlet Conditions). If a pump is mounted below the concentrate, be aware that air, which enters into the system, can return to the B-I-B, causing loss of the correct ratio. Choose a location that allows for easy sanitization and winterizing of the BRIX pump once mounted.

The inlet water source should be plumbed with 1/2"[13mm] inside diameter (I.D.) tubing and have a shut-off valve. The water source pressure should be regulated to a maximum of 50 psi [3.4 bar]. The SHURflo Water Pressure Reducing Valve (P/N: 183-0XX) can be used in place of a regulator.

A double check valve with vent may be required by local city ordinances to prevent the possibility of back flow entering the city water system. National Sanitizing Foundation (NSF) listed high-pressure braid tubing (3/8" or 1/2" [10 or 13mm] I.D.) should be used from the regulator to the water inlet of the pump, and from the water outlet fitting to the dispenser equipment.

INLET CONDITIONS

There are several types and sizes of Quick Connect/Disconnect (Q.C.D.) fittings/bags. The type of Q.C.D. used is determined by the company packaging the concentrate. Concentrates which are highly viscous and/or contain solids, may be packaged with a connection that uses a less restrictive Q.C.D. and 1/2"[13mm] I.D. tubing.

The length of tubing and vertical lift that a BRIX pump can accommodate at the concentrate inlet is dependent on the particular characteristics of the product. Also, colder concentrate temperatures adversely affect the systems inlet side due to the increase in viscosity. A brix system should not create over 7 inches of vacuum (in/Hg) [24 kPa] at the inlet fitting while the dispenser is open and flowing a finished drink. Inlet vacuum that is too high can evacuate the air suspended within some concentrates ("degassing"), causing inconsistency of brix or premature operation of the vacuum shut-off (if used). If high inlet vacuum conditions are encountered, use larger tubing I.D. although, shorter inlet line may be necessary. When a concentrate is highly viscous and/or contains large amounts of particulates it is advised that the inlet line be as short as possible and have a minimum amount of vertical lift.

Concentrate inlet lines must be NSF listed, clear heavy wall (1/8" [3mm] thick) vacuum tubing in either 1/2" or 3/8" [13 or 10mm] I.D. Allow enough tubing to prevent kinks and include some "extra" tubing in case service is needed at a later date. Always install stainless steel inserted Oetiker® clamps to all connections to prevent vacuum leaks.

The table below gives **general** recommendations for concentrate **INLET TUBING**. Actual line I.D. and length may vary.

CONCENTRATE	VISCOSITY	BRIX	TOTAL RUN FT. [M]	VERTICAL ② LIFT FT. [M]	TUBING I.D. [mm]
Tea	2.0 Cps	5:1	12' [3.6]	5' [1.5]	3/8" [10]
Sweet & Sour Mix	50. Cps	5:1	10' [3.0]	3' [1.0]	1/2" [13]
Tomato Juice	500 Cps	3:1	5' [1.5]	2' [0.6]	1/2" [13]
Orange Juice ↗	4000 Cps	5:1	3' [1.0]	1' [0.3]	1/2" [13]

↗Pulp product @ 40°F [5°C]

- Affects total run adversely

(Continued on next page)

In a facility where the concentrate cannot be located near the BRIX pump, it can be pumped from a remote location using a SHURflo beverage or juice gas pump (P/N 166-200-XX). The BRIX pump **must not** have positive pressure at the concentrate inlet line. The SHURflo Vacuum Regulator (P/N 186-054-00) must be installed prior to the concentrate inlet fitting of the pump, allowing concentrate to enter the pump under vacuum.

When an uninterrupted flow of concentrate is desired, the SHURflo Automatic Selector Valve (P/N 165-011 @ 12 in/Hg.[41 kPa]) can be plumbed in the inlet line to allow two or more B-I-B's to be connected. This allows B-I-B changes during convenient times without interruptions of finished drink dispensing.

OUTLET LINES TO THE DISPENSER

The total run of concentrate tubing from the BRIX pump to the dispenser (including cold plate if used) should be kept to a minimum. Concentrate outlet tubing should have minimal backpressure during pump operation. Backpressure is dependent on the line length & I.D., vertical lift, viscosity, temperature and dispenser valve flow.

The installation of a SHURflo Sanitizing Valve (P/N 94-056-00) is recommended with **all** drink concentrates. When the valve is moved to the "**Sanitize**" position it allows sanitizing solution to be directed from the concentrate chambers back into the water side of the pump. Plumb the concentrate outlet line from the pump to the bottom port of the valve. Connect the concentrate line to the dispenser at the port marked "**Dispense**". Install a "T" into the inlet water line and plumb to the "**Sanitize**" port as shown on pages 2 or 3.

Always use NSF listed, high pressure braid tubing (3/8" or 1/2" [10 or 13mm] I.D.) for pressurized lines and secure all connections with stainless steel inserted Oetiker® clamps. Tie-wrap all tubing securely to prevent kinks and relieve stress on pump fittings. Although it is recommended that line lengths are kept to a minimum, it is a good idea to allow some "extra" tubing in case service is required at a later date.

The table gives **general** recommendations for **OUTLET TUBING**. Actual line I.D. and lengths may vary.

CONCENTRATE	VISCOSITY	BRIX	TOTAL RUN FT [M]	VERTICAL LIFT FT.[M]	TUBING I.D. [mm]
Tea	2.0 Cps	5:1	57 [15.2]	8 [2.4]	3/8" [10]
Sweet & Sour Mix	50. Cps	5:1	43 [13.7]	6 [1.8]	3/8" [10]
Tomato Juice	500 Cps	3:1	30 [9.1]	4 [1.2]	3/8" [10]
Orange Juice ↗	4000 Cps	5:1	15 [4.5]	2 [0.6]	1/2" [13]

- Pulp product @ 40°[5° C]
- Affects total run adversely

START-UP PROCEDURE

1. Confirm that all tubing connections are properly clamped, fittings are tight, and lines are not kinked.
2. Install the Q.C.D. to B-I-B connector or insert inlet tubing into product container.
3. Open the water source valve slowly allowing the pump to cycle; maintain water pressure below the maximum of 50 psi.[3.4 bar].
4. Place a container under the dispenser to collect purged drink solution and hold the valve open. The concentrate will be drawn (ratio to water) to the pump with every stroke. Concentrate progress will be evident with each stroke. Allow the pump to cycle until the air within the system has been purged through the dispenser.
5. If the finished drink flow rate is not as desired, adjust the regulator (50 psi. max.[3.4 bar]). If using a fixed-pressure reducer, adjust the water shut-off valve to obtain the desired finish drink flow rate.

PUMP SANITIZING

The BRIX pump does not require any maintenance. However, depending on the concentrate type and its manufacturers requirements, the pump and **ALL** equipment in the system will need periodic sanitization. ***The frequency of this procedure is dependent on the water condition, temperature and concentrate type.*** Some concentrates may contain exceptionally "stringy" pulp that may become lodged within the Q.C.D. fitting and/or dispenser valve inhibiting performance. If concentrates of this kind are used, the system may need more frequent sanitizing to flush out build-up. With a "Teed" system it is recommended that the intervals between sanitization be more frequent than post-mix systems. The reason for this is that when a concentrate is mixed with water it may increase the possibility of product spoilage.

NOTE: The following procedure must be followed to assure compliance of NSF listed sanitizing requirements for the SHURflo BRIX pump (*only*). This procedure will not flush and sanitize the concentrate outlet line between the 3-way valve and dispenser. To properly sanitize the concentrate line, repeat the procedure in the "Dispense" mode and perform a product purge of the system. Consult other equipment manufacturer's instructions for their sanitizing requirements.

MATERIALS REQUIRED

1. **Non-sudsing liquid** detergent (such as common household automatic dishwasher liquid detergent)
2. Household bleach (Sodium Hypo chlorite solution; 5.25%) or equivalent
3. Clean five (5) gallon (U.S.) [19 liter] bucket
4. Measuring cup
5. An adapter is needed to hold the Q.C.D. fitting on the concentrate suction line open. A connector cut from an empty bag will work.

SANITIZING PROCEDURE

1. Fill the bucket with four (4) gallons [15.14 l] of warm water (120 - 180°F.)[48-82°C.].
 2. Measure four (4) ounces (½ cup) [118cc] of the liquid detergent and add to the water.
 3. Measure two (2) ounces (¼ cup) [60cc] of bleach and add to the water, then stir, mixing evenly.
- NOTE:** One half (½) ounce [15cc] of bleach per gallon [3.8 l] of water yields a solution of approximately 200 ppm Sodium Hypo chlorite needed to satisfy NSF sanitizing requirements.
4. Disconnect the concentrate line from the B-I-B and install the adapter on the quick disconnect so the line is open to the sanitizing solution. Place concentrate inlet line into the bucket so that the Q.C.D. will stay at the bottom.
 5. Position the SHURflo Sanitizing Valve in the "**Sanitize**" mode. Open the dispenser valve allowing **ALL** the solution to be pulled through the Q.C.D. fitting into the BRIX pump and out the water outlet line through to the dispenser.
 6. When the bucket is empty (approx 15 min.), return the valve back to the "**Dispense**" mode.
- CAUTION:** Failure to return the valve to the "**Dispense**" mode **before** starting the concentrate purge, will recontaminate the system. If this occurs, the sanitizing procedure steps **MUST** be performed again to the BRIX pump.
7. **PRODUCT PURGE:** Reconnect Q.C.D. of the inlet line to the concentrate supply. Open the dispenser allowing the pump to operate until all sanitizing solution is purged from the system, assuring that no off-taste will be detected.

TROUBLESHOOTING

When the BRIX pump system is properly installed and maintained it can continually deliver quality drinks with trouble-free operation. However, during "real world" operation various conditions may occur within the facility that affects the systems performance. Listed below are various situations that may affect a correctly installed system:

I. PUMP WILL NOT CYCLE:

- Verify there is adequate water pressure (30-50 psi.[2-3.4 bar]) at water inlet fitting.
- Verify that the dispenser valve operation (switch/solenoid), passages and lines are unrestricted. Flush and sanitize pump and outlet lines from pump fittings to the dispenser if restricted.
- Check to see if the pump has gone into "vacuum shut-off" (B-I-B only), although B-I-B container is full. Check for plugged or non-opening Q.C.D. fitting, or kinked or restricted inlet tubing. Flush and sanitize pump and outlet lines from pump fittings to the dispenser if restricted.

II. NO CONCENTRATE (PUMP CYCLES) / IMPROPER BRIX:

- Start by checking the items in part I. above.
- Verify that the Q.C.D. passage is opening completely when installed on the B-I-B connector. If concentrate is supplied from a tank, verify that the vent is open.
- Inspect for vacuum leaks at the concentrate inlet side. Carefully look for air bubbles at Q.C.D. or fittings while the pump is cycling.
- Determine if there was air packaged with the concentrate when the bags were filled. Stand the box up on end and pull the connector up, allowing air to rise up to the bag connector. Install a Q.C.D. and engage it on the bag connector opening the passage. Slowly press the Q.C.D. back down, expelling the air until concentrate appears, release the Q.C.D. closing the connector. This is referred to as "burping" the bag.
- Pump stroke should be even (time) in both directions of travel. If not even, remove concentrate valves (inlet/outlet) and inspect for debris or improper closing that interferes with their operation. (See "Valve Inspection" section)

III. PUMP CYCLES INTERMITTENTLY/ WILL NOT SHUT-OFF/ DRIPS:

- If the pump continues to cycle after B-I-B has emptied, verify that there are no vacuum leaks. Determine if the concentrate bag has an excessive (more than 1 cubic inch [16.4 cc]) amount of air. The pump will continue to ratio the air until "shut-off" vacuum (14-18 in/Hg. [48-61 kPa.]) is obtained. To verify that the vacuum shut-off is operating, allow the pump to operate. Pinch the inlet line off. This will create high vacuum causing the pump to stop operation.
- If concentrate drips from the (post-mix) dispenser, the problem may be concentrate particulates trapped under the piston seals allowing pressurized water to enter the concentrate chamber. Perform the sanitizing and flush procedure to the pump, which may flush the debris from under the seal. If the problem continues exchange the BRIX pump.

NOTE: If the concentrate B-I-B has been moved above the pump, head pressure from the B-I-B may be substantial enough to cause the dispenser to drip.

VALVE INSPECTION

Some concentrates after prolonged periods of contact without regular sanitizing, may cause the valves to become stiff or clogged with pulp and/or particulates. If a situation of this type is suspected, valve cartridges (4) can be removed for inspection.

1. Turn off water supply valve and relieve pressure. Remove each assembly by loosening the screw holding the cartridge. Turn the cartridge and then pull it out of the housing (Pliers may be required). Note inlet and outlet arrows molded on the pump housing for proper orientation of the respective valves.

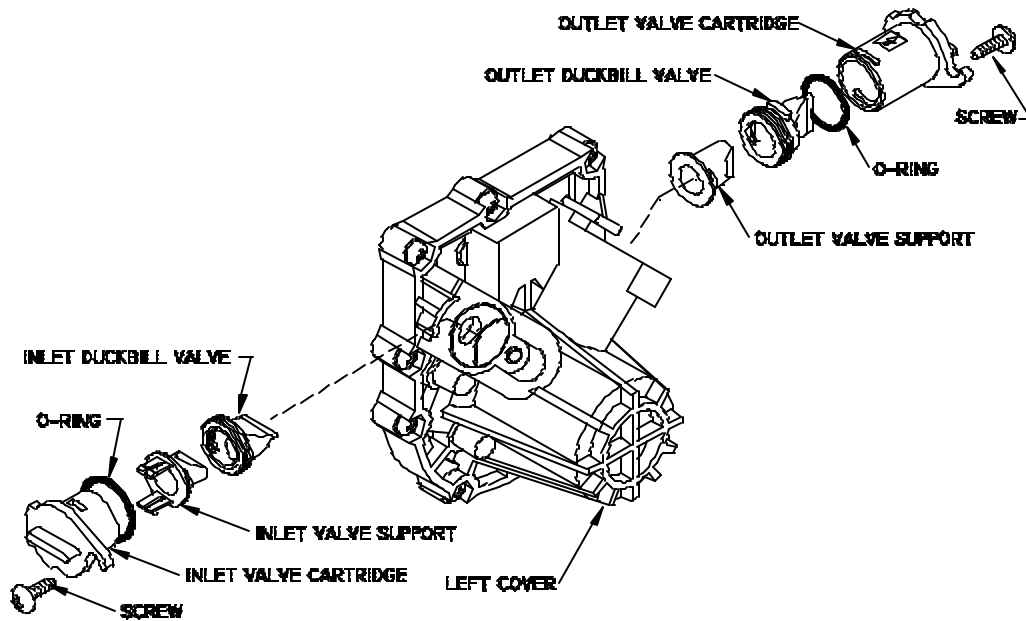

Placement of concentrate valves in housing (Left side shown).

2. Disassemble each cartridge individually. Do not confuse inlet and outlet components. Inspect the "Duck Bill" valves for tight seal in closed position. Valves should have quick action when pressed open between the fingers, and material should not be hard or stiff.

NOTE: Valve kit (# 94-402-02) is available for in field replacement, contact your SHURflo distributor for information. Complete instructions are included with each kit.

3. Reassemble each cartridge so that the valve support is not holding the valve open. Lubricate the serrated surface of the valves and O-rings with an NSF listed food grade lubricant. Reinsert the appropriate valves into the housing, turn back into position and tighten the screw. Be aware that the valves may turn, allowing the support to hold the valve open, when reinstalling in the housing.
4. Sanitize and recheck for even (time) stroke in both directions of piston travel.

WINTERIZING PROCEDURE

If a BRIX pump is subjected to temperatures below freezing, with either concentrate or water within the pump chambers, severe damage to the pump body may occur. It is advised that the following procedures be performed whenever the pump could be subjected to freezing temperatures.

1. Sanitize the system as outlined (ref. page 6), including the concentrate line to the dispenser. However, **DO NOT** perform Step: 7 "Product Purge" on the system.
2. Turn off the city water source valve and relieve pressure. Remove all the fittings (Inlet/Outlet) from the pump body and allow the solution to drain completely from the tubing.

(Continued next page)

3. Plumb a clean source of regulated compressed gas of either CO₂, Nitrogen, or filtered shop air to the water inlet connection of the pump. Remove the pump from its mounting by loosening the two (2) screws in the bracket slots. Turn the pump upside down (Inlet/Outlet ports pointing down) over a bucket.
4. Apply gas at **low pressures** (5-15 psi.[.35-1.0 bar]) to the water inlet port of the pump allowing it to cycle slowly until all the water trapped within the chambers is expelled. Turn the air off, remove the air line, and reinstall the pump to its mounting.
5. Open the dispenser valve(s) and expel all the solution from both the water and concentrate lines with the compressed air. (Refer to the equipment manufacturer's recommendations for purging dispensers and lines.) Reconnect all line fittings properly. Leave the inlet water source valve off and **DO NOT** reinstall Q.C.D. to concentrate container until the system is to be restarted.

NOTE: When the system is to be placed back into service, it **MUST** have the "Sanitizing Procedure" performed before finished drinks can be dispensed.

RETURN POLICY

Before a BRIX pump is returned to the factory, it *MUST* be sanitized/flushed when removed from service to prevent mold growth and health hazards. BRIX pump that do not receive periodic sanitization may be deemed as non-repairable. For pumps that do not operate, warm water from a faucet must be run through inlet fitting ports as soon as it is removed (see SHURflo Service Bulletin #1046). Pumps that are returned to SHURflo that are not sanitized/flushed will be dispositioned as a "**scrapped pump**" and **will not** be considered for testing, repair, or recondition.

When BRIX pumps are being returned to a service center, please contact the appropriate location prior to shipment to initiate a "Return Goods Authorization". SHURflo manufactures the BRIX pump components as needed per factory orders and service requirements, therefore when sending in a large number at one time, a 30 day "turn-a-round" or more could be expected.

RECONDITION PROGRAM (U.S. Market)

SHURflo service centers provide a remanufacturing program for BRIX pumps that are out of warranty. This service is provided depending on the pumps condition and results of the performance test. SHURflo service personnel will inform you as to cost and lead-time prior to initiating any work.

Returns may to be shipped with the postage prepaid to either of our service centers: SHURflo East, Elkhart, IN or SHURflo, Cypress, CA). Package all returns carefully. SHURflo will not be responsible for freight damage incurred during shipping to a service center. SHURflo reserves the right to the final disposition as to the condition of a pump returned for recondition.

A rebuild includes: new poppet assembly, plunger seals, valves, O-rings, fittings and any components necessary to update the pump to the latest specification.

All pumps receive a complete factory performance test and are sanitized per NSF listed requirements prior to shipping. All remanufactured BRIX pumps include a one (1) year warranty of similar intent as that of a new BRIX pump.

BRIX PUMP LIMITED WARRANTY

SHURflo warrants new BRIX pumps to be free from material and workmanship defects (under normal use and service) for a period of two years from the date of manufacture. An additional one-month (30 days) may be added to allow for storage and transit delays. In any event, the total limited warranty time period will not exceed 25 months from date of manufacture.

The limited warranty will not apply to any SHURflo pump that is improperly installed, misapplied, or incompatible with components not manufactured by SHURflo. SHURflo will not warrant any pump, which is modified or damaged outside the SHURflo factory.

All BRIX pumps **MUST** be flushed and sanitized when removed from service. Pumps which are returned to SHURflo, that have not been flushed and/or did not receive periodic sanitization, will not be considered for testing, rework, or warranty replacement and will be dispositioned as a "scrapped pump". Returns may be shipped with the postage prepaid to either of our service centers (SHURflo East; Elkhart, IN or West Coast facility; Cypress, CA). Package all returns carefully. SHURflo will not be responsible for freight damage incurred during shipping to a service center.

Upon receiving a pump, it will be tested per SHURflo's test criteria. SHURflo's obligation under this warranty policy is limited to the repair or replacement (whichever it deems advisable) of the unit. Pumps found not defective (under the terms of this limited warranty) are subject to charges to be paid by the returnee for the sanitization and packaging of "tested good" units.

No credit or labor allowances will be given to the returnee for BRIX pumps returned as defective. Warranty replacements will be shipped on a freight allowed basis. SHURflo reserves the right to choose the method of transportation.

This limited warranty is in lieu of all other warranties, expressed or implied, and no other person is authorized to give any other warranty or assume obligation or liability on SHURflo's behalf. SHURflo shall not be liable for any labor, damage or other expense, nor shall SHURflo be liable for any indirect, incidental or consequential damages of any kind incurred by the reason of the use or sale of any defective product or part.

TECHNICAL SPECIFICATIONS

DESIGN:	Positive Displacement; Fix Ratio (non-adjustable)
POWER SOURCE:	Potable Water
MATERIALS OF CONSTRUCTION:	Acetal Copolymer, EPDM, Santoprene, Silicone, 316 Stainless Steel- FDA sanctioned, NSF listed
TEMPERATURE LIMITS:	34 - 120°F [2-45°C]
DIMENSIONS	7.6" x 5.2" x 5.7" [19.3 x 13.2 x 14.47 cm]
WEIGHT:	2.2 lbs. [1 kgs]
DISPLACEMENT:	6.5 oz./ stroke [190cc] (concentrate & water)
FLOW RATE: (1 valve)	2-3 oz. [60-90cc] per sec. / varies with system design and concentrate
OPERATING PRESSURE:	50 PSI. [3.4 bar] MAX. / 25 PSI. [1.7 bar] MIN.
ACCURACY:	± 3% of available ratio
SOLD OUT: (available)	Automatic B-I-B Vacuum Shut-off @ 18-22 in. Hg. [48-61 kPa]
SUCTION LIFT (Wet):	25 in. Hg. [85 kPa] (minimum)
STANDARD FITTINGS:	3/8" [10mm] Barb, Plastic 90° configuration
AVAILABLE FITTINGS:	1/4" [6mm] , 3/8" [10mm], and 1/2" [13mm] barb, Plastic or Stainless Steel; Straight and/or 90° configurations
MODEL NUMBER MATRIX:	5000 - 2XX - 01 (without shut-off) (Model) - (ratio*) - 02 (with shut-off)
AVAILABLE RATIOS:	3.00 : 1 (*30) {Red dot} 4.00 : 1 (*40) {Blue dot} 4.20 : 1 (*42) 5.00 : 1 (*50) {Yellow dot} 5.30 : 1 (*53) 6.00 : 1 (*60) Other ratios available, contact the factory for specific



★ ISO Certified Facility



SHURflo reserves the right to update specifications, prices, or make substitutions.

SHURflo ★
5900 Katella Ave.
Cypress, CA 90630
(800) 854-3218 (562) 795-5200
FAX (562) 795-7564
Shipping/UPS: 5900 Katella Ave.
Bldg. B
Cypress, CA 90630

SHURflo East
52748 Park Six Court
Elkhart, IN 46514-5427
(800) 762-8094
(574) 262-0478
FAX (574) 264-2169
© 1998 Printed in USA

SHURflo Ltd.
Unit 5 Sterling Park
Gatwick Road, Crawley
West Sussex, RH10 2QT
United Kingdom
+44 1293 424000
FAX +44 1293 421880