



2-Gallon & 4-Gallon Economy Water Boosters

2-Gallon & 4-Gallon Economy Water Boosters



Standard Features

- Controls pressure fluctuations from incoming water systems and provides consistent flow of water to beverage dispensing equipment.
- Durable Aquatec pump/motor combo.
- Stainless steel water tank features McCann's proprietary diaphragm design. Made from NSF Certified food grade butyl rubber and designed to completely evacuate water from the tank when incoming water supply is shut off.
- Stainless steel fittings throughout.
- Schrader connection for easy tank pressure check.
- 180 PSI pressure relief valve.
- Base designed for both floor or table use, as well as wall-mount installation.
- Vibration dampening feet on both booster base and pump effectively control noise during operation.
- Certified by NSF and UL. Lead content certified for compliance with California AB-1953 & Vermont Act 193.



4570 West Colorado Blvd.
Los Angeles, CA 90039

Tel: 800.423.2429
Tech Svc: 800.367.4233

www.manitowocbeverage.com/us



Specifications

	2-Gallon Models	4-Gallon Models
Flow Rate	100 gph (378 lph) maximum	
Inlet/Outlet Pressure	Minimum inlet pressure 20 PSI (1.4 bar) Outlet pressure factory set at 80 PSI (5.5 bar) ON and 100 PSI (6.9 bar) OFF	
Tank Capacity	2 gallon (7.6 liter)	4.4 gallon (16.7 liter)
Water Available at 80-100 PSI	21 fl. ounces (0.62 liter)	51 fl. ounces (1.5 liter)
Total Water Reserve	93 fl. ounces (2.8 liter)	222 fl. ounces (6.6 liter)
Base	Stainless steel base with vibration dampening feet and carrying handle	Powder coated cold rolled steel base with vibration dampening feet
Manifold	Flexible tubing	Rigid stainless steel tube
Electrical	115V / 60 hz / 1 ph and 230V / 50/60Hz / 1 ph	
Pump	Positive displacement diaphragm pump	
Motor	1/5 HP, 1.3 amps at 115V and 0.65 amps at 230V	
Pressure Relief	180 psig relief setting	
Inlet/Outlet	3/8" or 1/2" stainless steel barbed hose fittings (indicated Inlet/Outlet on model number)	
Approximate Shipping Weights	16 lbs. (7.26 kg)	22 lbs. (9.98 kg)
Carton Volume	1.8 cu. ft. (51 liter)	2.5 cu. ft. (71 liter)

Model Number	Description	Model Number	Description
16-3172-1/2	Economy Water Booster, 115V 60hz, 2-Gallon SS Tank, 1/2" inlet/outlet fittings	16-3174-1/2	Economy Water Booster, 115V 60hz, 4-Gallon SS Tank, 1/2" inlet/outlet fittings
16-3172-3/8	Economy Water Booster, 115V 60hz, 2-Gallon SS Tank, 3/8" inlet/outlet fittings	16-3174-3/8	Economy Water Booster, 115V 60hz, 4-Gallon SS Tank, 3/8" inlet/outlet fittings
16-3182-3/8	Economy Water Booster, 230V 50hz, 2-Gallon SS Tank, 3/8" inlet/outlet fittings	16-3184	Economy Water Booster, 230V 50hz, 4-Gallon SS Tank, 1/2" inlet/outlet fittings

Model 16-3172

- A 11.875" (30.2 cm)
- B 15.625" (39.7 cm)
- C 9.00" (22.9 cm)

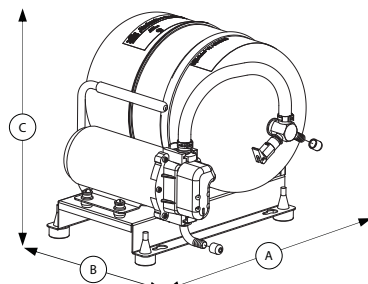

2-Gallon Model

Model 16-3174

- A 15.00" (38.1 cm)
- B 17.875" (30.5 cm)
- C 12.00" (45.4 cm)

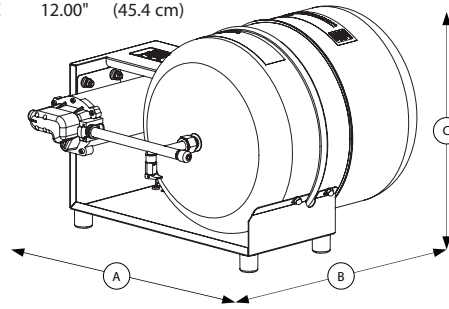

4-Gallon Model